



US009397576B2

(12) **United States Patent**
Chen et al.

(10) **Patent No.:** **US 9,397,576 B2**
(45) **Date of Patent:** **Jul. 19, 2016**

(54) **CONTROL CIRCUIT**

(56) **References Cited**

(71) Applicant: **NATIONAL TAIWAN UNIVERSITY,**
Taipei (TW)

(72) Inventors: **Yaow-Ming Chen,** Taipei (TW);
Cheng-Nan Wu, Taipei (TW)

(73) Assignee: **NATIONAL TAIWAN UNIVERSITY,**
Taipei (TW)

(*) Notice: Subject to any disclaimer, the term of this
patent is extended or adjusted under 35
U.S.C. 154(b) by 100 days.

U.S. PATENT DOCUMENTS

5,245,526 A *	9/1993	Balakrishnan	G05F 1/563 323/284
7,911,815 B2	3/2011	Wang et al.	
8,018,741 B2	9/2011	Huynh et al.	
2010/0194463 A1 *	8/2010	Moon	H02M 1/32 327/427
2012/0155121 A1 *	6/2012	Yao	H02M 3/33507 363/21.12
2013/0100711 A1 *	4/2013	Langeslag	H02M 3/33507 363/21.12
2013/0294118 A1 *	11/2013	So	H02M 3/33507 363/21.16

FOREIGN PATENT DOCUMENTS

TW 1430554 B 3/2014

* cited by examiner

Primary Examiner — Emily P Pham

Assistant Examiner — Demetrios A Gibson

(74) Attorney, Agent, or Firm — CKC & Partners Co., Ltd.

(57) **ABSTRACT**

A control circuit is adapted for controlling a converter. The converter includes a transformer and a power switch. The control circuit includes a current sensing unit, a current emulating unit, and a control unit. The current sensing unit senses a current flowing through the power switch coupled to a primary winding of the transformer. The current emulating unit determines a propagation delay period according to a voltage transient time of an auxiliary winding of the transformer and a turn-off time of the power switch, and retrieves several sampling times in a conduction period of the power switch according to the propagation delay period. The current emulating unit obtains a peak current and a valley current according to the sampling voltages corresponding to the sampling times. The control unit generates a control signal configured to control the power switch according to the peak current and the valley current.

13 Claims, 10 Drawing Sheets

(21) Appl. No.: **14/503,417**

(22) Filed: **Oct. 1, 2014**

(65) **Prior Publication Data**

US 2016/0006358 A1 Jan. 7, 2016

(30) **Foreign Application Priority Data**

Jul. 1, 2014 (TW) 103122674 A

(51) **Int. Cl.**

H02M 3/335 (2006.01)

H02M 1/00 (2006.01)

(52) **U.S. Cl.**

CPC **H02M 3/33507** (2013.01); **H02M 3/33523**
(2013.01); **H02M 2001/0009** (2013.01); **H02M**
2001/0025 (2013.01)

(58) **Field of Classification Search**

CPC H02M 2001/0009; H02M 2001/0025;
H02M 3/33507; H02M 3/33523; H01M 2/02;
H01M 2/1235; H01M 2/1241; H01M 10/052

See application file for complete search history.

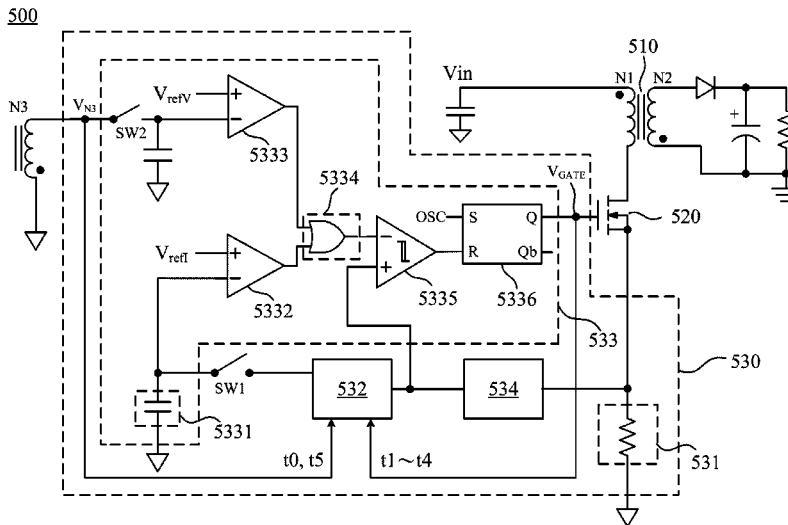

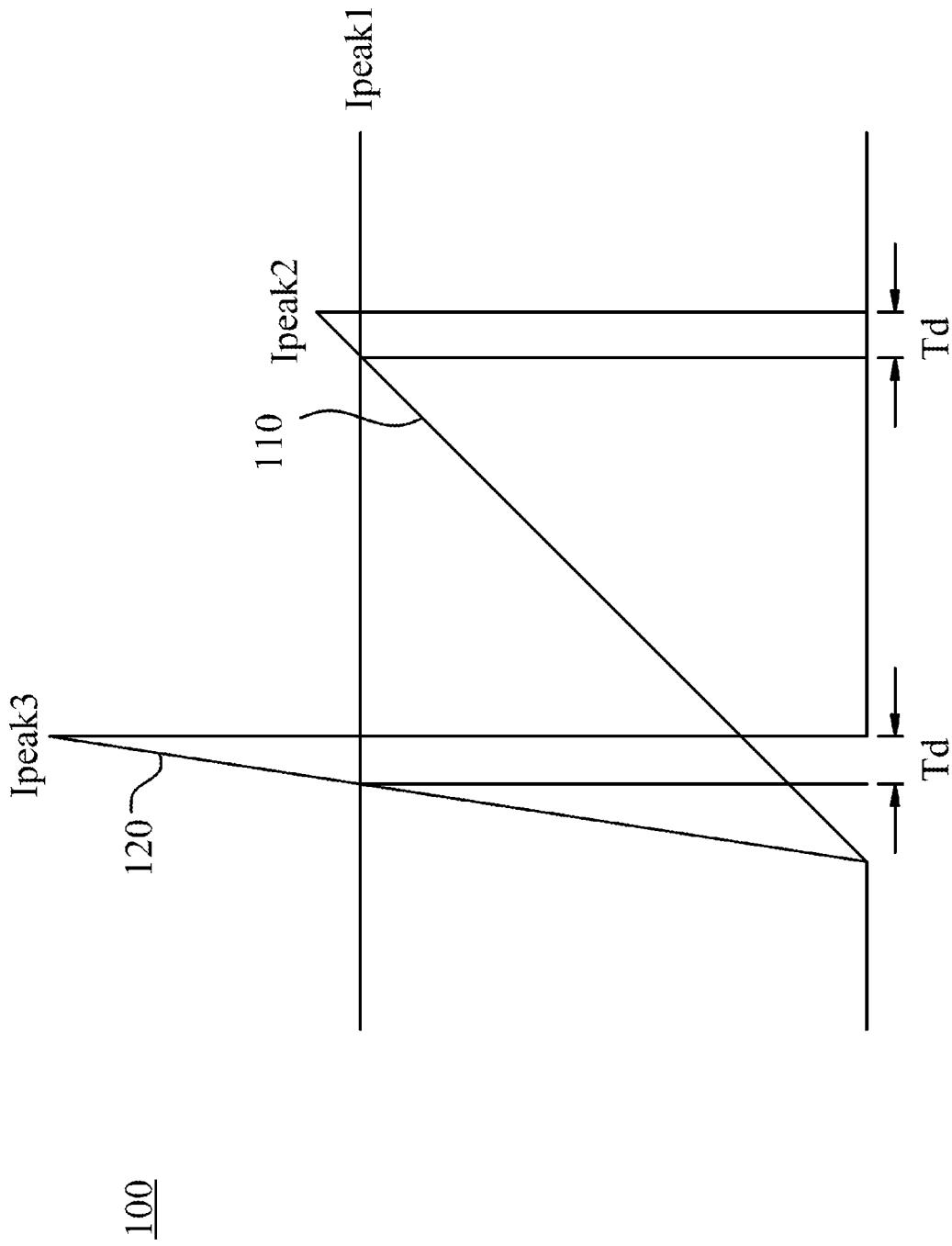

Fig. 1 (Prior art)

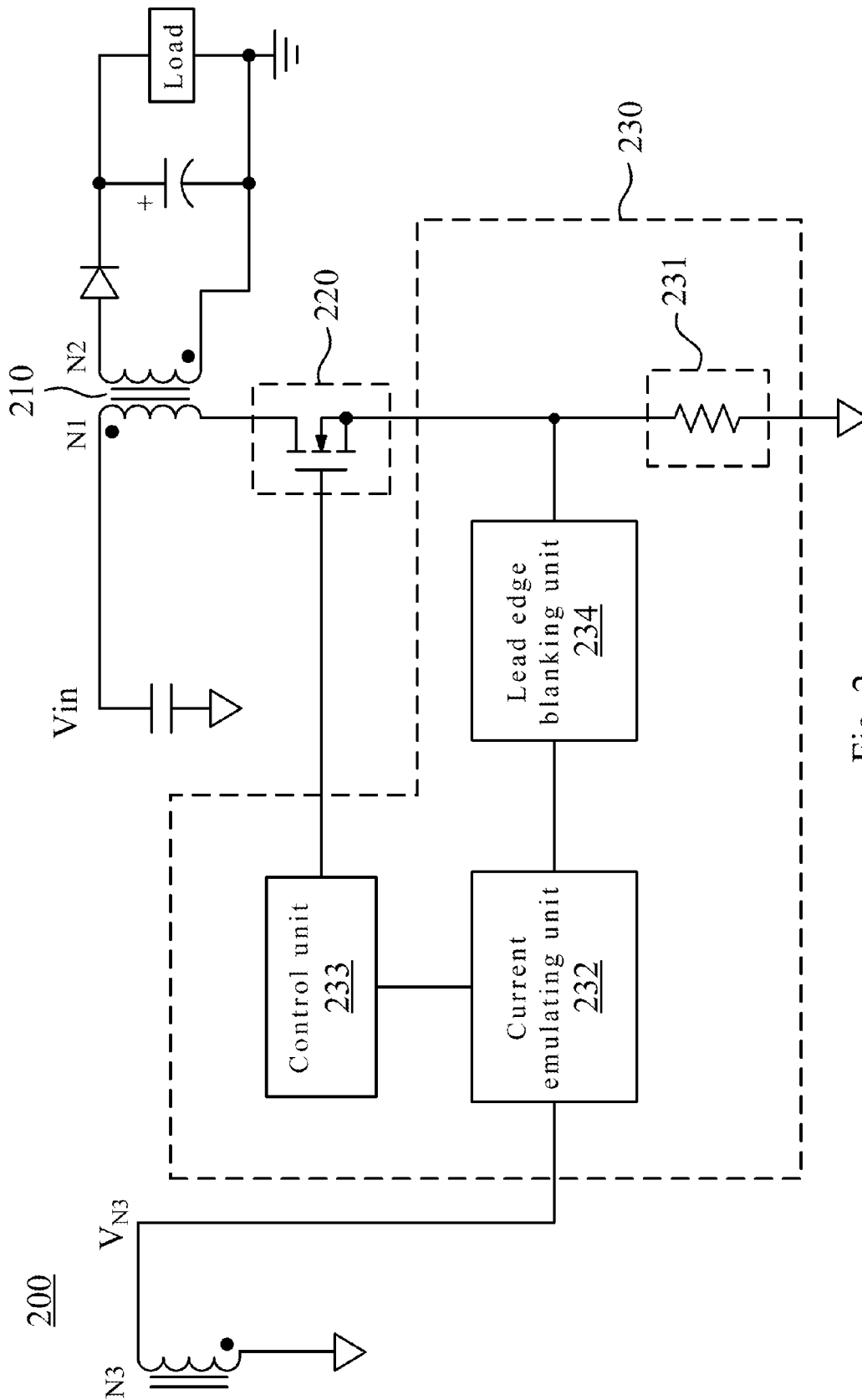

Fig. 2

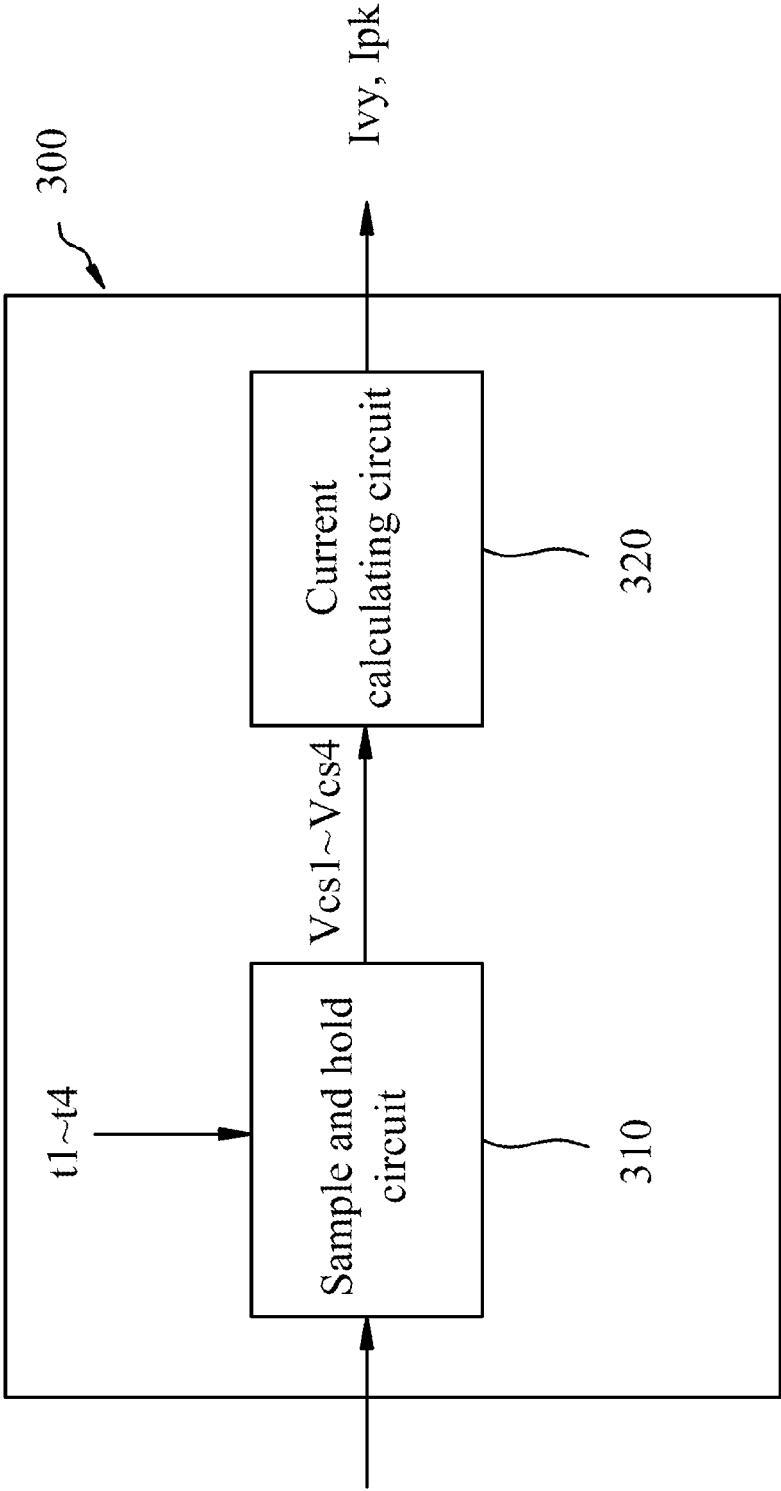

Fig. 3

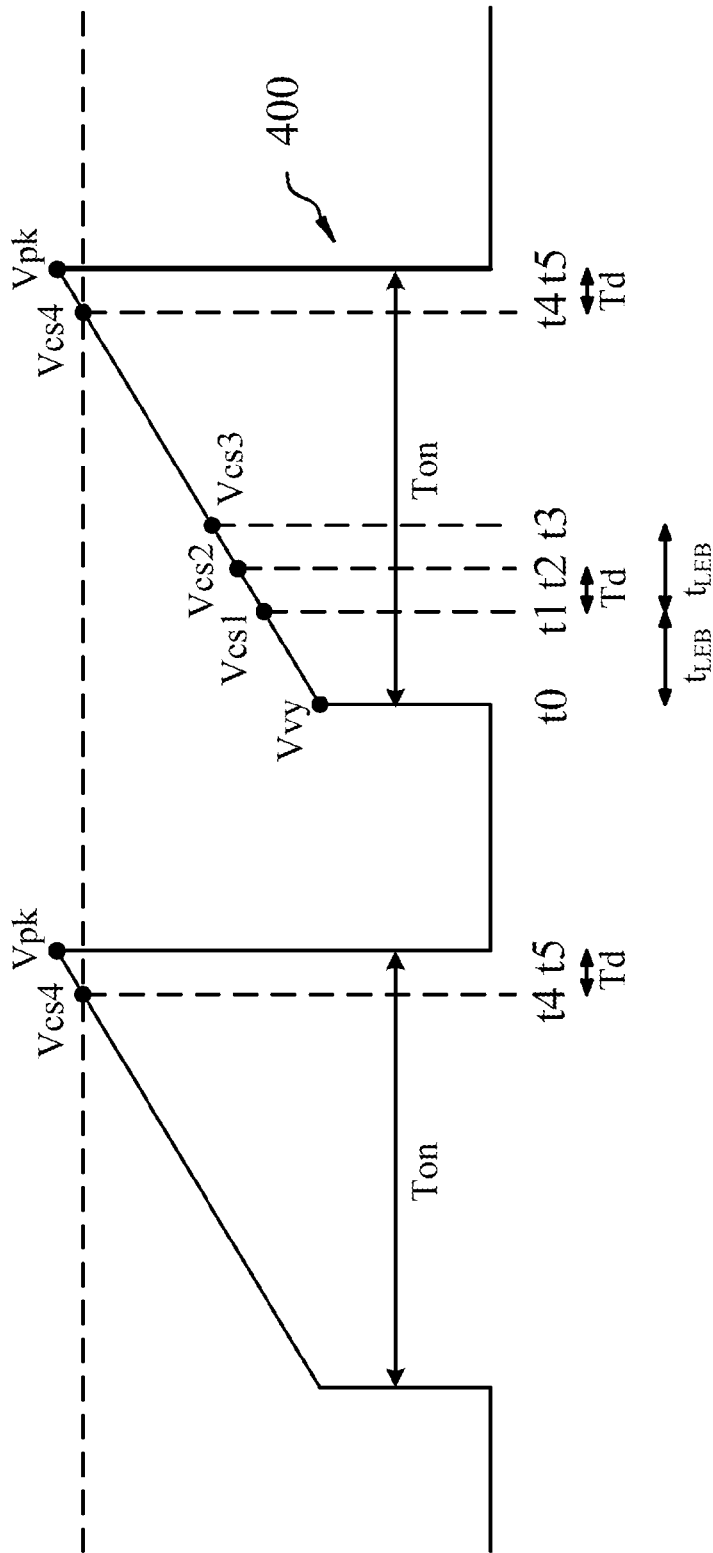

Fig. 4

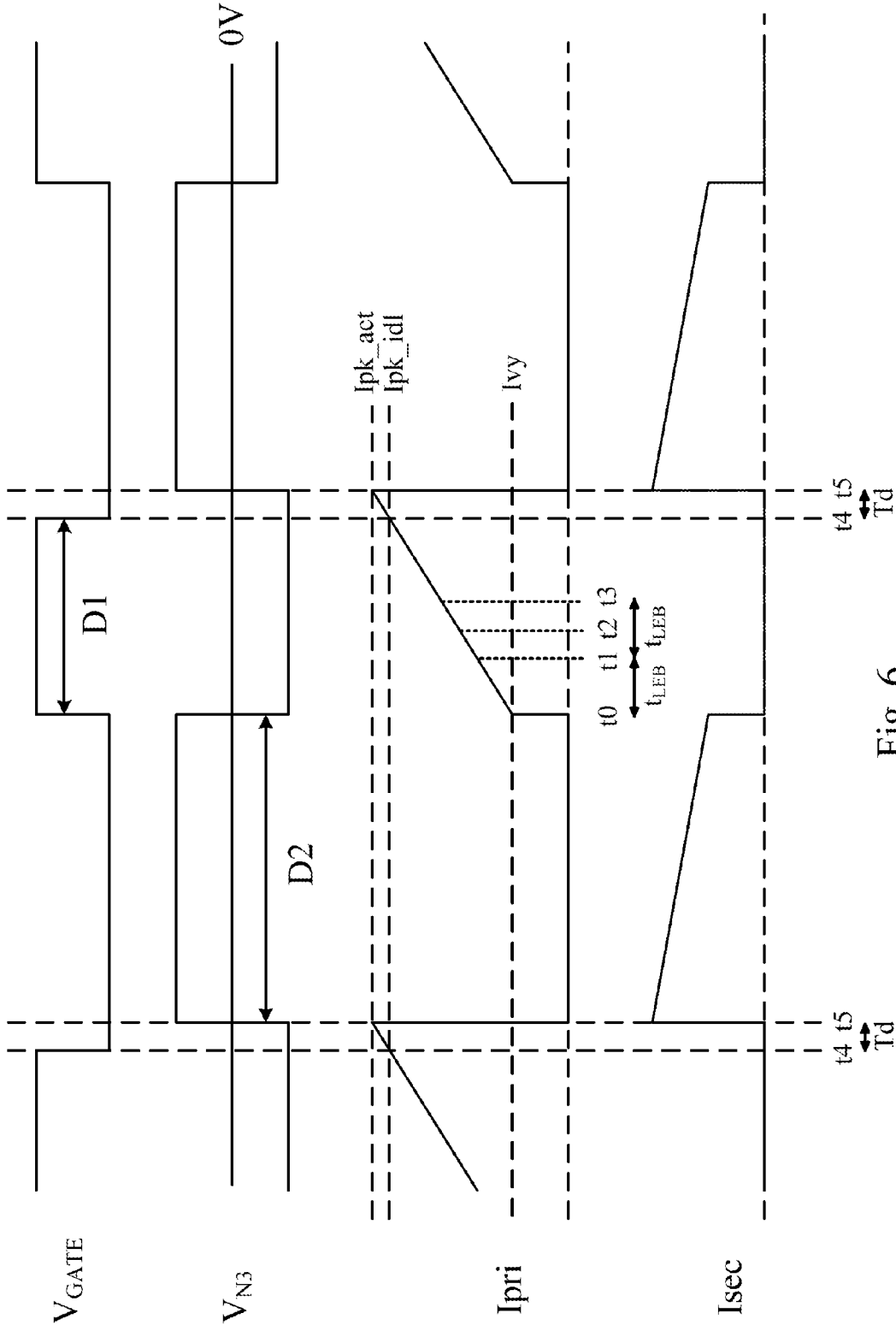

Fig. 6

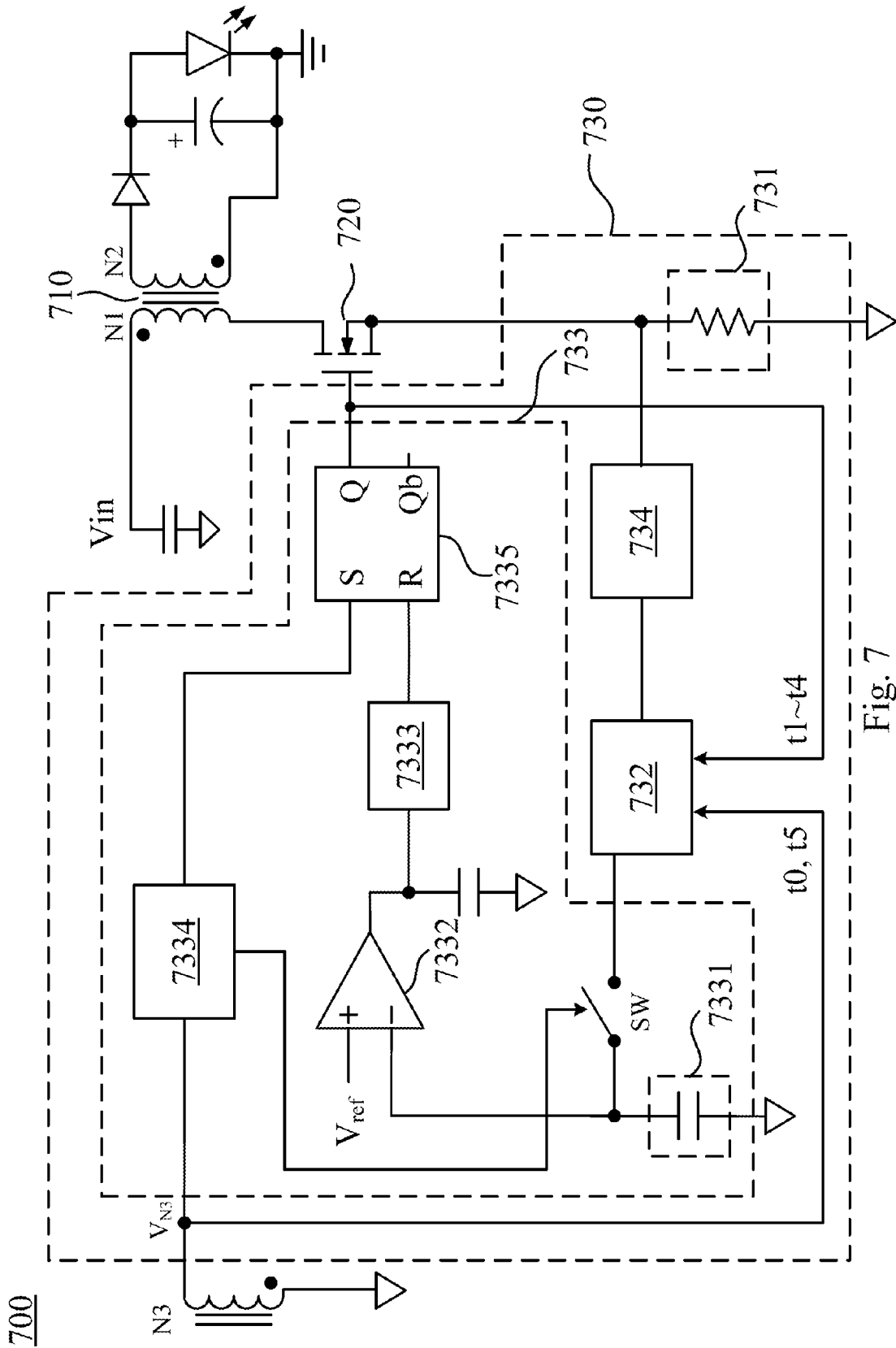

Fig. 7

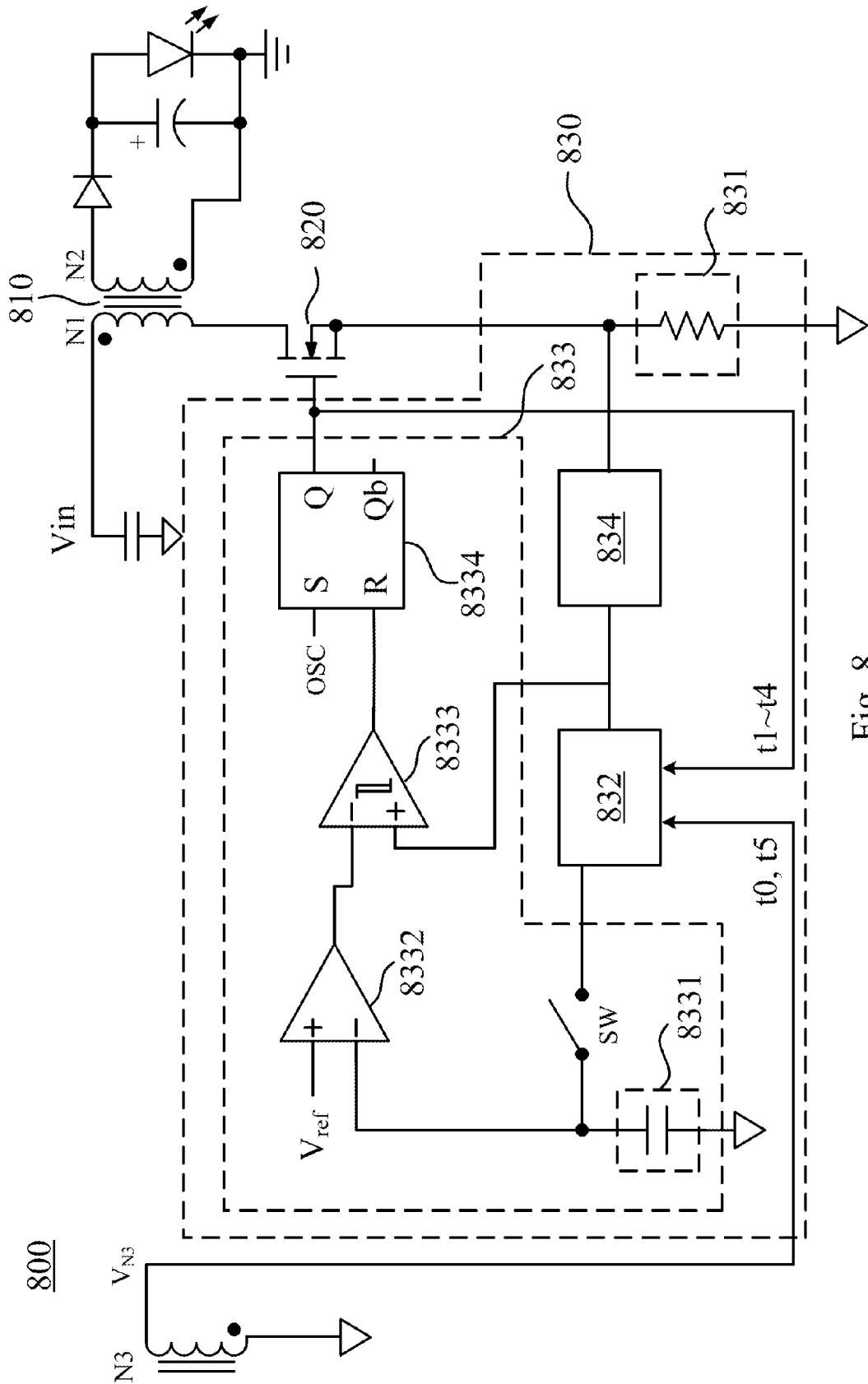

Fig. 8

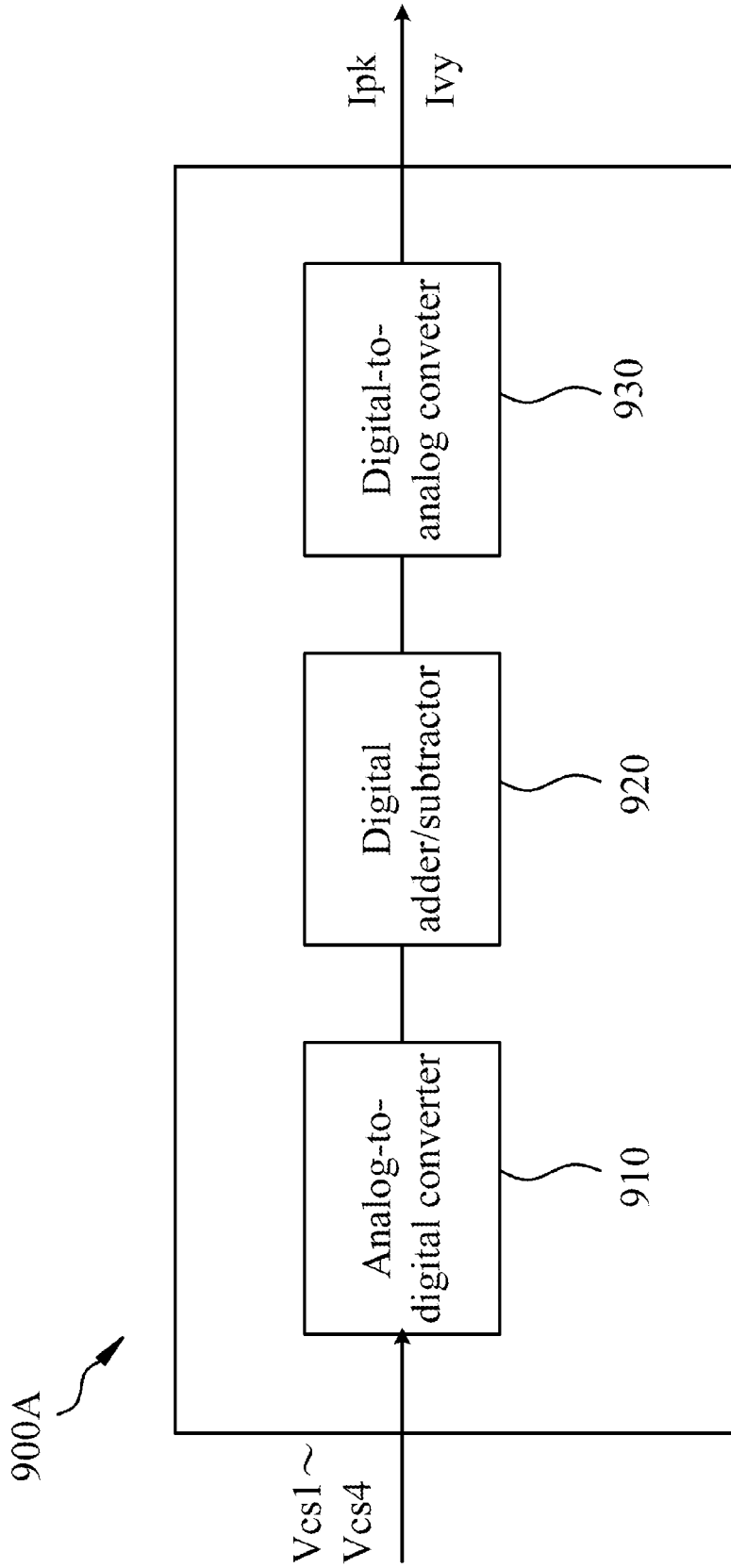

Fig. 9A

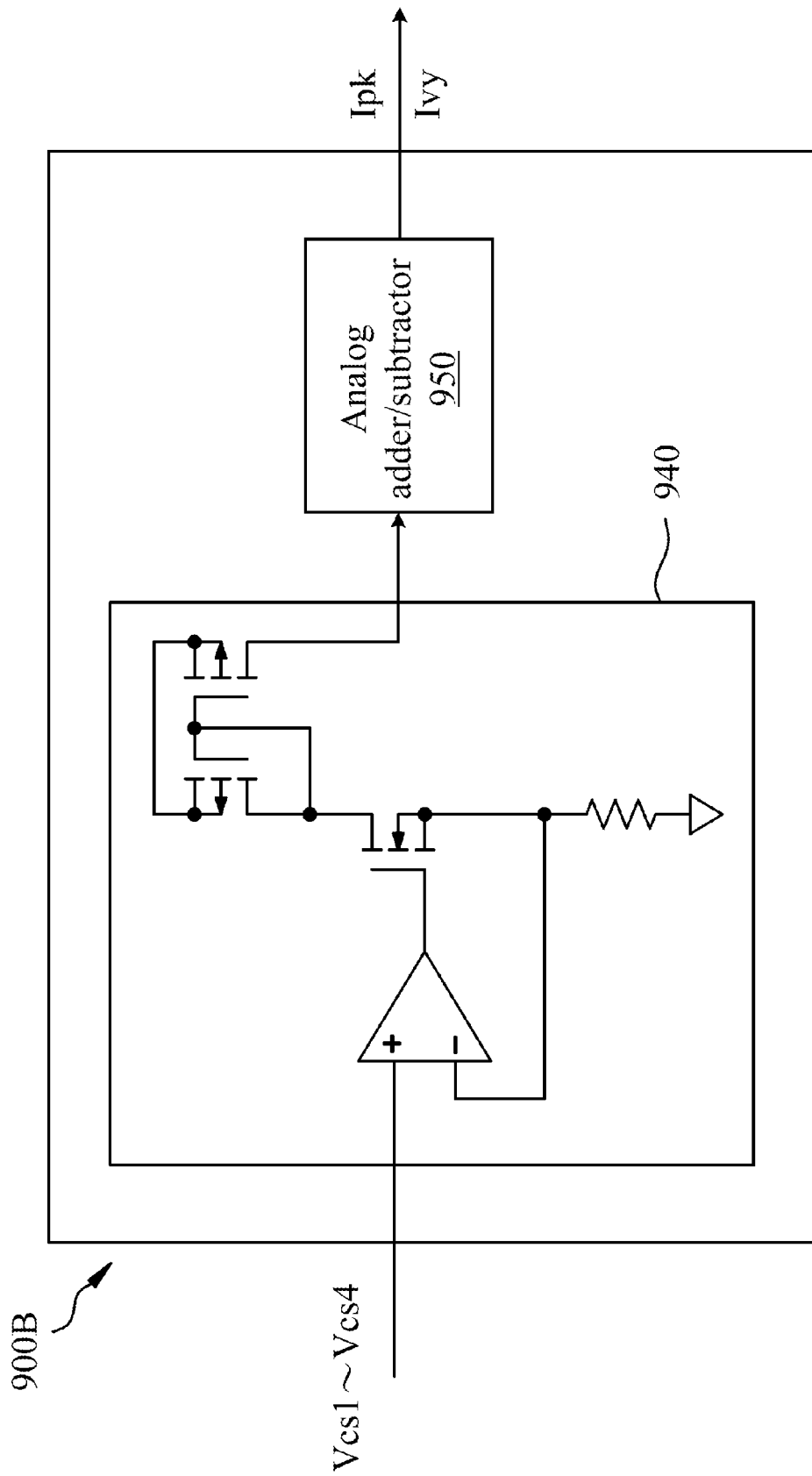

Fig. 9B

1 CONTROL CIRCUIT

RELATED APPLICATIONS

This application claims priority to Taiwanese Application Serial Number 103122674, filed Jul. 1, 2014, the entirety of which is herein incorporated by reference.

BACKGROUND

1. Technical Field

The present disclosure relates to a control circuit. More particularly, the present disclosure relates to a control circuit for controlling a constant output current of a converter.

2. Description of Related Art

A primary side regulator (PSR) can control an output current of a power converter. Specifically, the power converter includes a transformer. The conventional control approach for the primary side regulator is to control a conduction period of a power switch connected to a primary winding of the transformer so as to control an inductor current of the power converter. Accordingly, a constant output current of the power converter is achieved. Since the primary side regulator does not control the converter according to a feedback current from a secondary winding of the transformer, the circuitry of the primary side regulator is simple and the routing cost of the primary side regulator is low. However, the conventional primary side regulator has a defect. When the power switch is cut off, an error in the inductor current is occurred because of the effect of the propagation delay of the circuitry in the power converter, which results in an inaccurate cut-off point of the power switch and a variation in the output voltage and current. Accordingly, line regulation of the power converter is degraded.

As shown in FIG. 1, in a waveform **110** of an inductor current, the peak value of the inductor current is viewed as I_{peak1} . However, because of the effect of the propagation delay T_d of the circuitry, the actual peak value of the wave **110** of the inductor current should be I_{peak2} . Furthermore, when the input voltage increases or a tolerance of the inductance is occurred, waveform of the inductor current is changed to a waveform **120**, and thus the actual peak value of the inductor current is changed from I_{peak1} to I_{peak3} . In other words, an error amount of the inductor current is increased along with the increased output voltage. In each of the waveform **110** and the waveform **120**, an error caused by the propagation delay T_d results in variation of the output current and degradation of the line regulation. The conventional approach is to add a saw-limit compensation circuit for correcting an error of the output current. However, in this way, the tolerance of the output current of the power converter still fails to be corrected effectively and precisely.

SUMMARY

In order to solve aforementioned problems, the present disclosure is to provide a control circuit for controlling an input power or an output current of a converter. The converter includes a transformer and a power switch. A peak current and a valley current of a primary winding of a converter are obtained by calculating several sampling voltages, in which the sampling voltages are obtained at several sampling times in a conduction period of the power switch. Next, the power switch is controlled according to the peak current and the valley current so as to control the input power and the output current of the converter.

2

One aspect of the present disclosure is to provide a control circuit. The control circuit is adapted for controlling an input power or an output current of a converter. The converter includes a transformer and a power switch. The power switch is electrically coupled to a primary winding of the transformer. The control circuit includes a current sensing unit, a current emulating unit, and a control unit. The current sensing unit is electrically coupled to the power switch. The current sensing unit is configured to sense a current flowing through the power switch, and to convert the current into a voltage. The current emulating unit is electrically coupled to an auxiliary winding of the transformer, the power switch, and the current sensing unit. The current emulating unit is configured to determine a propagation delay period according to a voltage transient time of the auxiliary winding and a turn-off time of the power switch, and to retrieve several sampling times in a conduction period of the power switch according to the propagation delay period. The current emulating unit is configured to obtain several sampling voltages corresponding to the sampling times by the current sensing unit, and to obtain a peak current and a valley current flowing through the power switch according to the sampling voltages. The control unit is configured to generate a control signal according to the peak current and the valley current. The control signal is configured to control the power switch so as to control the input power or the output current of the converter.

According to one embodiment of the present disclosure, the sampling times includes a first sampling time, a second sampling time, and a third sampling time. A time interval between the first sampling time and the second sampling time is substantially equal to the propagation delay period. The third sampling time is the turn-off time of the power switch.

According to one embodiment of the present disclosure, the current emulating unit is configured to subtract a first sampling voltage corresponding to the first sampling time from a sum of a second sampling voltage corresponding to the second sampling time and a third sampling voltage corresponding to the third sampling time so as to obtain a peak voltage corresponding to the peak current.

According to one embodiment of the present disclosure, the sampling times further includes a fourth sampling time. A time interval between the fourth sampling time and the first sampling time is substantially equal to a time interval between the first sampling time and a conduction time of the power switch.

According to one embodiment of the present disclosure, the current emulating unit is configured to subtract a fourth sampling voltage corresponding to the fourth sampling time from two times of the first sampling voltage so as to obtain a valley voltage correspond to the valley current.

According to one embodiment of the present disclosure, the control circuit further includes a lead edge blanking unit electrically coupled to the current sensing unit and the current emulating unit. The lead edge blanking unit is configured to delay the current emulating unit for a blanking period when the power switch is conducted.

According to one embodiment of the present disclosure, the time interval between the fourth sampling time and the first sampling time, the time interval between the first sampling time and the conduction time of the power switch, and the blanking period are substantially the same.

According to one embodiment of the present disclosure, the current emulating unit includes a sample and hold circuit and a current calculating circuit. The sample and hold circuit is configured to sample the sampling voltages at the sampling

3

times. The current calculating circuit is configured to receive and calculate the sampling voltages so as to obtain the peak current and the valley current.

According to one embodiment of the present disclosure, the current calculating circuit includes a current mirror and an analog adder/subtractor. The current mirror is configured to convert the sampling voltage into a plurality of sampling currents. The analog adder/subtractor is configured to calculate the sampling currents so as to obtain the peak current and the valley current.

According to one embodiment of the present disclosure, the current calculating circuit includes an analog-to-digital converter, a digital adder/subtractor, and a digital-to-analog converter. The analog-to-digital converter is configured to receive the sampling voltages, and to convert the sampling voltages into several digital codes. The digital adder/subtractor is configured to receive and calculate the digital codes, and to generate a digital signal. The digital-to-analog converter is configured to receive the digital signal, and to convert the digital signal into the peak current and the valley current.

According to one embodiment of the present disclosure, the control unit includes an integrator unit and an error amplifier unit. The integrator unit electrically coupled to the current emulating unit. The integrator circuit is configured to integrate the peak current and the valley current so as to obtain an emulated voltage. The error amplifier unit is configured to compare the emulated voltage with a reference voltage so as to generate an error signal. The control unit generates the control signal according to the error signal.

According to one embodiment of the present disclosure, the control unit further includes a conduction time control unit, a zero current detection unit, and a flip-flop unit. The conduction time control unit is electrically coupled to the error amplifier unit. The conduction time control unit is configured to generate the control signal according to the error signal. The zero current detection unit is electrically coupled to the auxiliary winding. The zero current detection unit is configured to generate an enable signal according to the voltage transient time of the auxiliary winding. The flip-flop unit is configured to determine whether to output the control signal to the power switch according to the enable signal.

According to one embodiment of the present disclosure, the control unit further includes a comparison unit and a flip-flop unit. The comparison unit is configured to compare a current signal sensed by the current sensing unit with the error signal so as to generate the control signal. The flip-flop unit is configured to determine to whether to output the control signal to the power switch according to an oscillation signal.

According to one embodiment of the present disclosure, the control unit includes an integrator unit, a first error amplifier unit, a second error amplifier unit, a selection unit, a comparison unit, and a flip-flop unit. The integrator unit is electrically coupled to the current emulating unit. The integrator circuit is configured to integrate the peak current and the valley current so as to obtain an emulated voltage. The first error amplifier unit is configured to compare the emulated voltage with a first reference voltage so as to generate a first error signal. The second error amplifier unit is configured to compare a voltage of the auxiliary winding with a second reference voltage so as to generate a second error signal. The selection unit is configured to output corresponding one of the first error signal and the second error signal. The comparison unit is configured to compare a current signal sensed by the current sensing unit with the corresponding one of the first error signal and the second error signal so as to generate the

4

control signal. The flip-flop unit is configured to determine to output the control signal to the power switch according to an oscillation signal.

To sum up, the present disclosure provides a control circuit, which can correct an error in an inductor current caused by a propagation delay period of the converter of the circuitry, such that line regulation of the circuitry is improved.

It is to be understood that both the foregoing general description and the following detailed description are by examples, and are intended to provide further explanation of the disclosure as claimed.

BRIEF DESCRIPTION OF THE DRAWINGS

The disclosure can be more fully understood by reading the following detailed description of the embodiment, with reference made to the accompanying drawings as follows:

FIG. 1 depicts a waveform diagram of inductor currents of a prior art primary side regulator;

FIG. 2 depicts a schematic diagram of a converter according to a first embodiment of the present disclosure;

FIG. 3 depicts a schematic diagram of a current emulating unit according to one embodiment of the present disclosure;

FIG. 4 depicts a timing diagram of sampling times according to one embodiment of the present disclosure;

FIG. 5 depicts a schematic diagram of a converter according to a second embodiment of the present disclosure;

FIG. 6 depicts a timing diagram according to one embodiment of the present disclosure;

FIG. 7 depicts a schematic diagram of a converter according to a third embodiment of the present disclosure;

FIG. 8 depicts a schematic diagram of a converter according to a fourth embodiment of the present disclosure;

FIG. 9A depicts a schematic diagram of a current calculating circuit according to one embodiment of the present disclosure; and

FIG. 9B depicts a schematic diagram of a current calculating circuit according to another embodiment of the present disclosure.

DETAILED DESCRIPTION

Reference will now be made in detail to the present embodiments of the disclosure, examples of which are illustrated in the accompanying drawings. Wherever possible, the same reference numbers are used in the drawings and the description to refer to the same or like parts.

The terms used in this specification generally have their ordinary meanings in the art, within the context of the disclosure, and in the specific context where each term is used. Certain terms that are used to describe the disclosure are discussed below, or elsewhere in the specification, to provide additional guidance to the practitioner regarding the description of the disclosure.

It will be understood that, although the terms first, second, third etc. may be used herein to describe various elements, components, regions, layers and/or sections, these elements, components, regions, layers and/or sections should not be limited by these terms. These terms are only used to distinguish one element, component, region, layer or section from another element, component, region, layer or section. Thus, a first element, component, region, layer or section discussed below could be termed a second element, component, region, layer or section without departing from the teachings of the present disclosure.

It will be understood that when an element is referred to as being "connected" or "coupled" to another element, it can be

directly connected or coupled to the other element or intervening elements may be present. In contrast, when an element is referred to as being “directly connected” or “directly coupled” to another element, there are no intervening elements present.

FIG. 2 depicts a schematic diagram of a converter 200 according to a first embodiment of the present disclosure. As shown in FIG. 2, the converter 200 includes a transformer 210, a power switch 220, and a control circuit 230. The converter 200 receives an input voltage V_{in} through a primary winding N1 of the transformer 210, and a first current is formed on the primary winding N1. A second current is induced on a secondary winding N2 of the transformer 210 according to a variation of the first current. The second current is provided to a load electrically coupled to the secondary winding N2 of the transformer 210. The power switch 220 is electrically coupled to the primary winding N1 of the transformer 210. The control circuit 230 can control a conduction period or an operating frequency of power switch 220 so as to control an output of the converter 200. In other words, the control circuit 230 is configured to control an energy provided to the load by controlling the power switch 220 coupled to the primary winding N1 of the transformer 210.

The control circuit includes a current sensing unit 231, a current emulating unit 232, and a control unit 233. The current sensing unit 231 is electrically coupled to the power switch 220. The current sensing unit 231 is configured to sense a current flowing through the power switch 220, and to convert the current into a voltage. In one embodiment, the current sensing unit 231 may include a sensing resistance.

The current emulating unit 232 is electrically coupled to an auxiliary winding N3 of the transformer 210, the power switch 220, and the current sensing unit 231. The current emulating unit 232 is configured to determine a propagation delay period according to a voltage V_{N3} transient time of the auxiliary winding N3 and a turn-off time of the power switch 220. Moreover, the current emulating unit 232 is further configured to retrieve several sampling times in a conduction period of the power switch 220 according to the propagation delay period, and to obtain several sampling voltages at the sampling times by the current sensing unit 231. The current emulating unit 232 may obtain a peak current and a valley current flowing through the power switch 220 according to the sampling voltages.

The control unit 233 is configured to generate a control signal according to the peak current and the valley current. The control signal is configured to control the power switch 220 so as to control an output current (e.g., the second current) of the converter 200. In one embodiment, the control signal is configured to control a conduction period or an operating frequency of the power switch 220, such that the converter 200 can output a constant current.

FIG. 3 depicts a schematic diagram of a current emulating unit 300 according to one embodiment of the present disclosure. The current emulating unit 300 can be applied in the control circuit 230 of FIG. 2, but the present disclosure is not limited in this regard. As shown in FIG. 3, the current emulating unit 300 includes a sample and hold circuit 310 and a current calculating circuit 320. The sample and hold circuit 310 is electrically coupled to the current sensing unit (not shown in the figure). The sample and hold circuit 310 is configured to obtain several sampling voltages V_{cs1} - V_{cs4} corresponding to several currents flowing through the power switch (not shown in the figure) at several sampling times $t1$ - $t4$, in which the currents are sensed by the current sensing unit. The current calculating circuit 320 is configured to receive and calculate the sampling voltages V_{cs1} - V_{cs4} so as

to obtain values of a valley current I_{vy} and a peak current I_{pk} . Therefore, by performing aforementioned sampling operations with the sample and hold circuit 310, and by calculating the actual valley current I_{vy} and the actual peak current I_{pk} with the current calculating circuit 320, variations in the output current can be improved.

Reference is made to FIG. 2, FIG. 3, and FIG. 4. FIG. 4 depicts a timing diagram of sampling times according to one embodiment of the present disclosure. As shown in FIG. 4, in the timing diagram of sampling times as they related to an inductor current 400, the current emulating unit 232 may retrieve sampling times $t1$ - $t4$ in a conduction period T_{on} of the power switch 220. In one embodiment, a sampling time $t4$ is a turn-off time of the power switch 220. The current emulating unit 232 may obtain sampling voltages V_{cs1} - V_{cs4} at the sampling times $t1$ - $t4$.

In one embodiment, the actual peak current is occurred in a peak time $t5$. Since the peak time $t5$ is a time after the power switch 220 is cut off, the actual peak voltage V_{pk} corresponding to the peak current at the time $t5$ is unable to be directly obtained with respect to the timing diagram of actual circuitry.

Since when current is conducted on the secondary winding N2 of the transformer 210 (i.e., when a value of an inductor current of the secondary winding N2 is substantially equal to a value of the peak current), a voltage transient is occurred on the auxiliary winding N3 of the transformer 230, too. Accordingly, the current emulating unit 232 may determine a time when a value of the inductor current of the secondary winding N2 is substantially equal to a value of the peak current, that is, the peak time $t5$, by sensing a voltage transient time of the auxiliary winding N3. Moreover, the current emulating unit 232 may further determine a propagation delay period T_d by sensing a time when the power switch is cut off, that is, the sampling time $t4$. Specifically, the propagation delay period T_d is substantially equal to a time interval between the peak time $t5$ and the sampling time $t4$. Accordingly, the current emulating unit 232 may obtain the propagation delay period T_d from a previous conduction period T_{on} of the power switch 220 by aforementioned operations, and may retrieve the sampling times $t1$ - $t4$ in the present conduction period T_{on} of the power switch 220 according to the propagation delay period T_d .

In one embodiment, a time interval between the sampling time $t2$ and the sampling time $t1$ is substantially equal to the propagation delay period T_d . Accordingly, the current emulating unit 232 may subtract the sampling voltage V_{cs1} from the sum of the sampling voltage V_{cs4} and the sampling voltage V_{cs2} so as to obtain the actual peak voltage V_{pk} , and obtain the actual peak current I_{pk} according to the peak voltage V_{pk} . Therefore, the actual valley voltage V_{vy} and the actual peak voltage V_{pk} can be calculated by the aforementioned operations according to the linearity of the inductor current, such that the error in output current can be improved according to the valley voltage V_{vy} and the peak voltage.

In one embodiment, the converter 200 of FIG. 2 can be operated in hybrid mode. In other words, the converter 200 can be operated in continuous conduction mode (CCM) or discontinuous conduction mode (DCM). Generally, the user must determine whether a valley current flowing through the power switch (or a valley voltage sensed by the sensing resistance) is zero when the power switch is conducted so as to realize that the converter is operated in continuous conduction mode or discontinuous conduction mode. However, in actual circuitry, the precise initial voltage fails to be directly measured because of the fact that the sampling voltage mea-

sured at the time when the power switch **320** is conducted is usually accompanied with spikes and ringing, which distorts the sampling voltage.

Accordingly, in one embodiment, the control circuit **230** further includes a lead edge blanking unit **234**. The lead edge blanking unit **234** is electrically coupled to the current sensing unit **231** and the current emulating unit **232**. The lead edge blanking unit **234** is configured to delay the current emulating unit **232** for a blanking period t_{LEB} when the power switch **220** is conducted. In other words, when the power switch **200** is conducted, the current emulating unit **232** retrieves the sampling voltages V_{cs1} - V_{cs4} at the sampling times $t1$ - $t4$ after the blanking period t_{LEB} .

In one embodiment, a time interval between the sampling time $t3$ and the sampling time $t1$, a time interval between the sampling time $t1$ and a conduction time of the power switch **220** (i.e., an initial time $t0$), and the blanking period t_{LEB} are substantially the same, that is, $t_{LEB}=t3-t1=t1-t0$.

Therefore, according to the aforementioned configuration of the sampling times, the current emulating unit **232** may subtract the sampling voltage V_{cs3} from the two times of the sampling voltage V_{cs1} so as to obtain the valley voltage V_{vy} . Next, the current emulating unit **232** can determine an operation mode of the converter **200** according to a value of the valley voltage V_{vy} . When the valley voltage V_{vy} is substantially larger than zero, the current emulating unit **232** determines that the converter **200** is operated in continuous conduction mode. When the valley voltage V_{vy} is substantially equal to zero, the current emulating unit **232** determines that the converter **200** is operated in discontinuous conduction mode. Therefore, the correct valley voltage V_{vy} can be obtained according to the linearity of the inductor current and configuration of sampling times, and the operation mode of the converter **200** can be correctly determined by a value of the valley voltage V_{vy} .

Moreover, the current emulating unit **232** further obtains the actual valley current I_{vy} according to the valley voltage V_{vy} . Therefore, the actual valley voltage V_{vy} and the actual peak voltage V_{pk} can be calculated by the aforementioned operations according to the linearity of the inductor current. Accordingly, the corresponding valley current I_{vy} and the corresponding peak current I_{pk} can be obtained, thereby the tolerance in output current of the converter **200** can be improved.

FIG. 5 depicts a schematic diagram of a converter **500** according to a second embodiment of the present disclosure. As shown in FIG. 5, the converter **500** includes a transformer **510**, a power switch **520**, and the control circuit **530**. The control circuit **530** includes a current sensing unit **531**, a current emulating unit **532**, a control unit **533**, and a lead edge blanking unit **534**. Operations and connections of the current sensing unit **531**, the current emulating unit **532**, the control unit **533**, and the lead edge blanking unit **534** are similar to those of the current sensing unit **231**, the current emulating unit **232**, the control unit **233**, and the lead edge blanking unit **234** of FIG. 2, and thus they are not further detailed herein. In the present embodiment, the control unit **533** includes an integrator unit **5331**, a first error amplifier unit **5332**, a second error amplifier **5333**, a selection unit **5334**, a comparison unit **5335**, and a flip-flop unit **5336**.

The integrator unit **5331** is electrically coupled to the current emulating unit **532** through a switch **SW1**, and is configured to integrate the valley current and the peak current so as to obtain an emulated voltage. In one embodiment, the integrator unit **5331** includes a capacitor, but the present embodiment is not limited in this regard.

A first terminal of the first error amplifier unit **5332** is configured to receive a reference voltage V_{ref} . A second terminal of the first error amplifier unit **5332** is electrically coupled to the integrator unit **5331**, and is configured to receive the emulated voltage. The first error amplifier unit **5332** is configured to compare the emulated voltage with the reference voltage V_{ref} so as to generate a first error signal. An output terminal of the first error amplifier unit **5332** is configured to output the first error signal.

A first terminal of the second error amplifier unit **5333** is configured to receive a reference voltage V_{refV} . A second terminal of the second error amplifier unit **5333** is electrically coupled to an auxiliary winding **N3** of the transformer **510** through a switch **SW2**, and is configured to receive a voltage V_{N3} of the auxiliary winding **N3**. The second error amplifier unit **5333** is configured to compare the voltage V_{N3} of the auxiliary winding **N3** with the reference voltage V_{refV} so as to generate a second error signal. An output terminal of the second error amplifier unit **5333** is configured to output the second error signal. In one embodiment, a turn-off period of the switch **SW1** and the switch **SW2** is substantially equal to a discharging period of a secondary winding **N2** of the transformer **510**.

A first terminal of the selection unit **5334** is electrically coupled to the output terminal of the first error amplifier unit **5332**. A second terminal of the selection unit **5334** is electrically coupled to the output terminal of the second error amplifier unit **5333**. An output terminal of the selection unit **5334** is electrically coupled to a first terminal of the comparison unit **5335**. The output terminal of the selection unit **5334** is configured to output corresponding one of the first error signal and the second error signal to the comparison unit **5335**. In one embodiment, the selection unit **5334** includes an OR gate, but the present disclosure is not limited in this regard.

A second terminal of the comparison unit **5335** is electrically coupled to the current sensing unit **531** through the lead edge blanking unit **534**. Accordingly, the converter **500** can be operated in current mode, such that the converter **500** can achieve faster output response. The comparison unit **5335** is configured to compare the corresponding one of the first error signal and the second error signal with a current signal sensed by the current sensing unit **531** so as to generate a control signal. An output terminal of the comparison unit **5335** is configured to output the control signal.

A first terminal of the flip-flop unit **5336** is configured to receive an oscillation signal **OSC**. A second terminal of the flip-flop unit **5336** is electrically coupled to the output terminal of the comparison unit **5335**. An output terminal of the flip-flop unit **5336** is electrically coupled to a control terminal of the power switch **520**. The flip-flop unit **5336** is configured to determine whether to output the control signal to the power switch **520** according to the oscillation signal **OSC**. In one embodiment, the flip-flop unit **5336** includes a RS flip-flop, but the present disclosure is not limited in this regard. In the present embodiment, the control signal is configured to control a conduction period of the power switch unit **520** so as to control the converter **500** to output a constant voltage and a constant current.

Reference is made to FIG. 5 and FIG. 6. FIG. 6 depicts a timing diagram according to one embodiment of the present disclosure. As shown in FIG. 6, the primary winding **N1** of the transformer **510** begins to generate a current I_{p1} according to the input voltage V_{in} during a conduction period **D1** of the power switch **520**. In ideal condition, when the power switch **520** is cut off, the secondary winding **N2** of the transformer **510** should generate an output current I_{sec} to the load according to an ideal peak current I_{pk_idl} . However, because of the

propagation delay period T_d of the converter **500**, the secondary winding **N2** of the converter **500** actually generates the output current I_{sec} according to a peak current I_{pk_act} , such that an error is occurred in the output current I_{sec} provided to the load. Accordingly, in order to obtain the actual peak current so as to improve the tolerance in the output current, one may obtain the sampling voltages at the aforementioned sampling times $t1$ - $t4$ by the current emulating unit **532**, and calculate the sampling voltages so as to obtain the actual peak current and the actual valley current (e.g., the peak current I_{pk_act}). The sampling and calculating operations are similar to the aforementioned embodiments, and thus they are not further detailed herein.

After the actual peak current and the actual valley current are obtained, an average output current provided to the load can be further obtained. In one embodiment, average output current I_{avg} can be obtained by a formula:

$$I_{avg} = \frac{n_{21}D_2}{2} \times (I_{pk_act} + I_{mi}),$$

in which n_{21} represents a turns ratio of a secondary winding **N2** to a primary winding **N1**, D_2 represents a discharging period of the secondary winding **N2**, I_{pk_act} represents a peak current of the primary winding **N1**, I_{vy} represents a valley current of the primary winding **N1**. Moreover, the peak current can be obtained by subtracting a current sensed at the sampling time $t1$ from the sum of a current sensed at the sampling time $t4$ and a current sensed at the sampling time $t2$. The valley current can be obtained by subtracting a current sensed at the sampling time $t3$ from two times of a current sensed at the sampling time $t1$. Moreover, a time interval between the sampling time $t2$ and the sampling time $t1$ is substantially equal to a propagation delay period T_d of the converter **500**. Additionally, a time interval between the sampling time $t3$ and the sampling time $t1$, a time interval between the sampling time $t1$ and a conduction time of the power switch **520**, and the blanking period t_{LEB} are substantially the same.

Similarly, after the valley current I_{vy} is obtained, the current emulating unit **532** can determine an operation mode of the converter **500** according to a value of the valley current I_{vy} . When the valley current I_{vy} is substantially larger than zero, the current emulating unit **532** determines that the converter **500** is operated in continuous conduction mode. When the valley current is substantially equal to zero, the current emulating unit **532** determines that the converter **500** is operated in discontinuous conduction mode. It is noted that the actual peak current and the actual valley current are obtained by calculating the sampling currents in the present disclosure, but the sampling currents may be obtained from sampling the sampling voltages.

By aforementioned embodiments, not only can a constant output current of the converter be achieved, but also a constant input power can be achieved by changing a conduction time of the switch **SW1**. Specifically, charge amount is equal to current multiplied by time, and power is equal to electrical energy (i.e., charge amount multiplied by voltage) per time. Accordingly, by aforementioned embodiments, charge amount of the primary winding can be controlled in a constant value (i.e., the current is controlled in a constant value), such that the constant input power of the converter can be achieved.

FIG. 7 depicts a schematic diagram of a converter **700** according to a third embodiment of the present disclosure. The converter **700** is adapted for driving an LED load. The

converter **700** includes a transformer **710**, a power switch **720**, and a control circuit **730**. The control circuit **730** includes a current sensing unit **731**, a current emulating unit **732**, a control unit **733**, and a lead edge blanking unit **734**. Operations and connections of the current sensing unit **731**, the current emulating unit **732**, the control unit **733**, and the lead edge blanking unit **734** are similar to those of the current sensing unit **531**, the current emulating unit **532**, the control unit **533**, and the lead edge blanking unit **534** of FIG. 5, and thus they are not further detailed herein. In the present embodiment, the control unit **733** includes an integrator unit **7331**, an error amplifier unit **7332**, a conduction time control unit **7333**, a zero current detection unit **7334**, and a flip-flop unit **7335**.

The integrator unit **7331** is electrically coupled to the current emulating unit **732** through a switch **SW**. The integrator circuit **7331** is configured to integrate the peak current and the valley current so as to obtain an emulated voltage. In one embodiment, the integrator unit **7331** includes a capacitor, but the present disclosure is not limited in this regard. In one embodiment, a turn-off period of the switch **SW** is substantially equal to a discharging period of a secondary winding **N2** of the transformer **710**.

A first terminal of the error amplifier unit **7332** is configured to receive a reference voltage V_{ref} . A second terminal of the error amplifier **7332** is electrically coupled to the integrator unit **7331**, and is configured to receive the emulated voltage. The error amplifier unit **7332** is configured to compare the emulated voltage with the reference voltage V_{ref} so as to generate an error signal. An output terminal of the error amplifier unit **7332** is configured to output the error signal.

A first terminal of the conduction time control unit **7333** is electrically coupled to the output terminal of the error amplifier unit **7332**. An output terminal of the conduction time control unit **7333** is electrically coupled to a first terminal of the flip-flop unit **7335**. The conduction time control unit **7333** is configured to generate a control signal according to the error signal.

A first terminal of the zero current detection unit **7334** is electrically coupled to an auxiliary winding **N3** of the transformer **710**. An output terminal of the zero current detection unit **7334** is electrically coupled to a second terminal of the flip-flop unit **7335**. The zero current detection unit **7334** is configured to generate an enable signal according to a voltage V_{N3} transient time of the auxiliary winding **N3**.

The first terminal of the flip-flop unit **7335** is configured to receive the control signal. The second terminal of the flip-flop unit **7335** is configured to receive the enable signal. The flip-flop unit **7335** is configured to determine whether to output the control signal to the power switch **720** according to the enable signal. In one embodiment, the flip-flop unit **7335** includes a RS flip-flop, but the present disclosure is not limited in this regard. In the present embodiment, the control signal is configured to control a conduction period of the power switch **720** so as to control the converter **700** to output a constant current.

FIG. 8 depicts a schematic diagram of a converter **800** according to a fourth embodiment of the present disclosure. The converter **800** is adapted for driving an LED load. The converter **800** includes a transformer **810**, a power switch **820**, and a control circuit **830**. The control circuit **830** includes a current sensing unit **831**, a current emulating unit **832**, a control unit **833**, and a lead edge blanking unit **834**. Operations and connections of the current sensing unit **831**, the current emulating unit **832**, the control unit **833**, and the lead edge blanking unit **834** are similar to those of the current sensing unit **731**, the current emulating unit **732**, the control

unit **733**, and the lead edge blanking unit **734** of FIG. 7, and thus they are not further detailed herein. In the present embodiment, the control unit **833** includes an integrator unit **8331**, an error amplifier unit **8332**, a comparison unit **8333**, and a flip-flop unit **8334**. Operations and connections of the integrator unit **8331** and the error amplifier unit **8332** are similar to those of the integrator unit **7331** and the error amplifier unit **7332** of FIG. 7, and thus they are not further detailed herein.

A first terminal of the comparison unit **8333** is electrically coupled to an output terminal of the error amplifier unit **8332**, and is configured to receive an error signal. A second terminal of the comparison unit **8333** is electrically coupled to the current sensing unit **831** through the lead edge blanking unit **834**. Accordingly, the converter **800** can be operated in current mode, such that the converter **800** can achieve faster output response. The comparison unit **8333** is configured to compare a current signal sensed by the current sensing unit **831** with the error signal so as to generate the control signal. An output terminal of the comparison unit **8333** is configured to output the control signal.

A first terminal of the flip-flop unit **8334** is configured to receive an oscillation signal OSC. A second terminal of the flip-flop unit **8334** is electrically coupled to the output terminal of the comparison unit **8333**. An output terminal of the flip-flop unit **8334** is electrically coupled to a control terminal of the power switch **820**. The flip-flop unit **8334** is configured to determine to whether to output the control signal to the power switch **820** according to the oscillation signal. In one embodiment, the flip-flop unit **8334** includes a RS flip-flop, but the present disclosure is not limited in this regard. In the present embodiment, the control signal is configured to control a conduction period of the power switch **820** so as to control an input power of the converter **800** to be constant.

In this way, by calculating the actual valley current and the actual peak current with the current emulating unit **832**, and by controlling the conduction period of the power switch **820** according to the control signal which is generated according to the valley current and the peak current with the control unit **833**, a constant input power control of the converter **800** can be achieved.

FIG. 9A depicts a schematic diagram of a current calculating circuit **900A** according to one embodiment of the present disclosure. In the present embodiment, the current calculating circuit **900A** can be implemented in digital form. As shown in FIG. 9A, the current calculating circuit **900A** includes an analog-to-digital converter **910**, a digital adder/subtractor **920**, and a digital-to-analog converter **930**. An input terminal of the analog-to-digital converter **910** is configured to receive the sampling voltages V_{cs1} - V_{cs4} , to convert the sampling voltages V_{cs1} - V_{cs4} into several digital codes, and to output the digital codes to the digital adder/subtractor **920**. The digital adder/subtractor **920** is configured to receive and calculate the digital codes, to generate a digital signal, and to output the digital signal to the digital-to-analog converter **930**. The digital-to-analog converter is configured to receive the digital signal, and to convert the digital signal into the peak current I_{pk} and the valley current I_{vy} .

FIG. 9B depicts a schematic diagram of a current calculating circuit **900B** according to another embodiment of the present disclosure. In the present embodiment, the current calculating circuit **900B** can be implemented in analog form. As shown in FIG. 9B, the current calculating circuit **900B** includes several current mirrors **940** and an analog adder/subtractor **950**. In order to describe the current calculating circuit **900B** conveniently, the number of the current mirror **940** is one in the present figure. The current mirror **940** is

configured to receive the sampling voltages V_{cs1} - V_{cs4} , and to convert the sampling voltage V_{cs1} - V_{cs4} into several sampling currents. The analog adder/subtractor **950** is configured to receive and calculate the sampling currents so as to obtain the peak current I_{pk} and the valley current I_{vy} .

To sum up, the present disclosure provides a control circuit, which can correct an error in an inductor current caused by a propagation delay period of the converter of the circuitry, such that line regulation of the circuitry is improved.

It will be apparent to those skilled in the art that various modifications and variations can be made to the structure of the present disclosure without departing from the scope or spirit of the disclosure. In view of the foregoing, it is intended that the present disclosure cover modifications and variations of this disclosure provided they fall within the scope of the following claims.

What is claimed is:

1. A control circuit for controlling an input power or an output current of a converter, wherein the converter comprises a transformer and a power switch, and the power switch is electrically coupled to a primary winding of the transformer, the control circuit comprising:

a current sensing unit electrically coupled to the power switch, the current sensing unit configured to sense a current flowing through the power switch, and to convert the current into a voltage;

a current emulating unit electrically coupled to an auxiliary winding of the transformer, the power switch, and the current sensing unit, the current emulating unit configured to determine a propagation delay period according to a voltage transient time of the auxiliary winding and a turn-off time of the power switch, to retrieve a plurality of sampling times in a conduction period of the power switch according to the propagation delay period, to obtain a plurality of sampling voltages at the sampling times by the current sensing unit, and to obtain a peak current and a valley current flowing through the power switch according to the sampling voltages;

a control unit configured to generate a control signal according to the peak current and the valley current, wherein the control signal is configured to control the power switch so as to control the input power or the output current of the converter,

wherein the sampling times comprises a first sampling time, a second sampling time, and a third sampling time, wherein a time interval between the first sampling time and the second sampling time is substantially equal to the propagation delay period, and the third sampling time is the turn-off time of the power switch.

2. The control circuit of claim 1, wherein the current emulating unit is configured to subtract a first sampling voltage corresponding to the first sampling time from a sum of a second sampling voltage corresponding to the second sampling time and a third sampling voltage corresponding to the third sampling time so as to obtain a peak voltage corresponding to the peak current.

3. The control circuit of claim 1, wherein the sampling times further comprises a fourth sampling time, wherein a time interval between the fourth sampling time and the first sampling time is substantially equal to a time interval between the first sampling time and a conduction time of the power switch.

4. The control circuit of claim 3, wherein the current emulating unit is configured to subtract a fourth sampling voltage corresponding to the fourth sampling time from two times of the first sampling voltage so as to obtain a valley voltage correspond to the valley current.

13

5. The control circuit of claim 3, wherein the control circuit further comprises a lead edge blanking unit electrically coupled to the current sensing unit and the current emulating unit, the lead edge blanking unit is configured to delay the current emulating unit for a blanking period when the power switch is conducted.

6. The control circuit of claim 5, wherein the time interval between the fourth sampling time and the first sampling time, the time interval between the first sampling time and the conduction time of the power switch, and the blanking period are substantially the same.

7. The control circuit of claim 1, wherein the current emulating unit comprises:

- a sample and hold circuit configured to sample the sampling voltages at the sampling times; and
- a current calculating circuit configured to receive and calculate the sampling voltages so as to obtain the peak current and the valley current.

8. The control circuit of claim 7, wherein the current calculating circuit comprises:

- a current mirror configured to convert the sampling voltage into a plurality of sampling currents; and
- an analog adder/subtractor configured to calculate the sampling currents so as to obtain the peak current and the valley current.

9. The control circuit of claim 7, wherein the current calculating circuit comprises:

- an analog-to-digital converter configured to receive the sampling voltages, and to convert the sampling voltages into a plurality of digital codes;
- a digital adder/subtractor configured to receive and calculate the digital codes, and to generate a digital signal; and
- a digital-to-analog converter configured to receive the digital signal, and to convert the digital signal into the peak current and the valley current.

10. The control circuit of claim 1, wherein the control unit comprises:

- an integrator unit electrically coupled to the current emulating unit, the integrator circuit configured to integrate the peak current and the valley current so as to obtain an emulated voltage; and
- an error amplifier unit configured to compare the emulated voltage with a reference voltage so as to generate an error signal;

14

wherein the control unit generates the control signal according to the error signal.

11. The control circuit of claim 10, wherein the control unit further comprises:

- a conduction time control unit electrically coupled to the error amplifier unit, the conduction time control unit configured to generate the control signal according to the error signal;
- a zero current detection unit electrically coupled to the auxiliary winding, the zero current detection unit is configured to generate an enable signal according to the voltage transient time of the auxiliary winding; and
- a flip-flop unit configured to determine whether to output the control signal to the power switch according to the enable signal.

12. The control circuit of claim 10, wherein the control unit further comprises:

- a comparison unit configured to compare a current signal sensed by the current sensing unit with the error signal so as to generate the control signal; and
- a flip-flop unit configured to determine to whether to output the control signal to the power switch according to an oscillation signal.

13. The control circuit of claim 1, the control unit comprises:

- an integrator unit electrically coupled to the current emulating unit, the integrator circuit configured to integrate the peak current and the valley current so as to obtain an emulated voltage; and
- a first error amplifier unit configured to compare the emulated voltage with a first reference voltage so as to generate a first error signal;
- a second error amplifier unit configured to compare a voltage of the auxiliary winding with a second reference voltage so as to generate a second error signal;
- a selection unit configured to output corresponding one of the first error signal and the second error signal;
- a comparison unit configured to compare a current signal sensed by the current sensing unit with the corresponding one of the first error signal and the second error signal so as to generate the control signal; and
- a flip-flop unit configured to determine to output the control signal to the power switch according to an oscillation signal.

* * * * *