

The
United
States
of
America



The Director of the United States
Patent and Trademark Office

Has received an application for a patent for a new and useful invention. The title and description of the invention are enclosed. The requirements of law have been complied with, and it has been determined that a patent on the invention shall be granted under the law.

Therefore, this

United States Patent

Grants to the person(s) having title to this patent the right to exclude others from making, using, offering for sale, or selling the invention throughout the United States of America or importing the invention into the United States of America, and if the invention is a process, of the right to exclude others from using, offering for sale or selling throughout the United States of America, or importing into the United States of America, products made by that process, for the term set forth in 35 U.S.C. 154(a)(2) or (c)(1), subject to the payment of maintenance fees as provided by 35 U.S.C. 41(b). See the Maintenance Fee Notice on the inside of the cover.

Michelle K. Lee

Deputy Director of the United States Patent and Trademark Office

(12) **United States Patent**
Wang et al.

(10) **Patent No.:** **US 9,492,836 B2**
(45) **Date of Patent:** **Nov. 15, 2016**

(54) **COATING MODULE**

- (71) Applicant: **National Taiwan University**, Taipei (TW)
- (72) Inventors: **An-Bang Wang**, Taipei (TW); **Yu-Wen Hsieh**, Taipei (TW); **Yu-Ju Liu**, Taipei (TW)
- (73) Assignee: **National Taiwan University**, Taipei (TW)

(*) Notice: Subject to any disclaimer, the term of this patent is extended or adjusted under 35 U.S.C. 154(b) by 183 days.

(21) Appl. No.: **13/762,378**

(22) Filed: **Feb. 8, 2013**

(65) **Prior Publication Data**

US 2014/0000511 A1 Jan. 2, 2014

(30) **Foreign Application Priority Data**

Jun. 29, 2012 (TW) 101123480 A

- (51) **Int. Cl.**
B05C 1/00 (2006.01)
B05C 5/00 (2006.01)
B05C 5/02 (2006.01)

- (52) **U.S. Cl.**
CPC **B05C 5/00** (2013.01); **B05C 5/0254** (2013.01); **B05C 5/0262** (2013.01)

- (58) **Field of Classification Search**
None
See application file for complete search history.

(56) **References Cited**

U.S. PATENT DOCUMENTS

2,916,012 A	12/1959	Hergenrother	
3,570,725 A	3/1971	Baker et al.	
3,825,379 A	7/1974	Lohkamp et al.	
4,220,114 A	9/1980	Radowicz	
4,299,186 A	11/1981	Pipkin et al.	
4,358,332 A *	11/1982	Rodish	156/356
4,445,458 A *	5/1984	O'Brien	118/401
4,774,109 A	9/1988	Hadzimiralis et al.	
5,547,094 A *	8/1996	Bartels et al.	216/33

(Continued)

FOREIGN PATENT DOCUMENTS

JP	H08501979	3/1996
JP	2001-029860	2/2001

(Continued)

OTHER PUBLICATIONS

“Office Action of Korea Counterpart Application” with English translation thereof, issued on May 21, 2014, p. 1-p. 9.

(Continued)

Primary Examiner — Dah-Wei D Yuan
Assistant Examiner — Jethro M Pence
(74) *Attorney, Agent, or Firm* — Jianq Chyun IP Office

(57) **ABSTRACT**

A coating module is suitable to coat a liquid onto a substrate and includes two plates and a diversion structure, in which there is a slot between the plates, and the slot has a slot inlet and a slot outlet, and one of the plates has an injecting port. The diversion structure makes the injecting port communicated with the slot inlet, in which the liquid is configured to enter the diversion structure via the injecting port, and flow to the slot inlet through the diversion structure, then flow into the slot via the slot inlet and then outflows from the slot via the slot outlet to be coated onto the substrate.

15 Claims, 15 Drawing Sheets

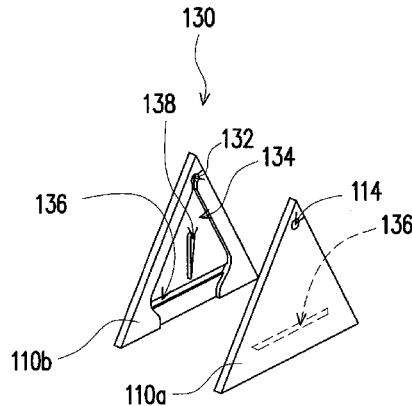

(56)

References Cited

U.S. PATENT DOCUMENTS

2004/0256496 A1 12/2004 Harris et al.
 2005/0184086 A1* 8/2005 Raterman et al. 222/1
 2006/0062899 A1 3/2006 Rankin, Jr. et al.
 2012/0219657 A1 8/2012 Kondo

FOREIGN PATENT DOCUMENTS

JP 2001-507987 6/2001
 JP 2002-103361 4/2002
 JP 2002096474 4/2002
 JP 2003-200444 7/2003
 JP 2004-283820 10/2004
 JP 2004-314053 11/2004
 JP 2004-330094 11/2004
 JP 2006015210 1/2006
 JP 2006310235 11/2006
 JP 2007136454 6/2007
 JP 2009-513365 4/2009
 JP 2009-202141 9/2009

TW	358969	5/1999
TW	517011	1/2003
TW	1250045	3/2006

OTHER PUBLICATIONS

“Search Report of Europe Counterpart Application” with Applicant’s comments thereof, issued on Aug. 6, 2013, p. 1-p. 6.
 Thierry G. Charbonneaux, “Design of Sheet Dies for Minimum Residence Time Distribution: A Review,” *Polymer-Plastics Technology and Engineering* 30(7), Oct. 1991, pp. 665-684.
 Liu et al., “Development of a Novel Slot Die Coater Manufacturing Technology and its Application for Multilayer ceramic capacitor (MLCC),” 7th International Microsystems, Packaging, Assembly and Circuits Technology Conference (IMPACT), Oct. 2012, pp. 1-4.
 Wang et al, Abstract of “Could a Die Be Disposable?—Design and Test of a Silicon-Wafer-Based Slot Die Coater,” 16th International Coating Science and Technology Symposium, Sep. 9-12, 2012, p. 1.
 “Office Action of Taiwan Counterpart Application”, issued on Nov. 21, 2014, p. 1-p. 5.
 “Notice of Allowance of Japan Counterpart Application”, issued on Oct. 27, 2015, p. 1-p. 3.

* cited by examiner

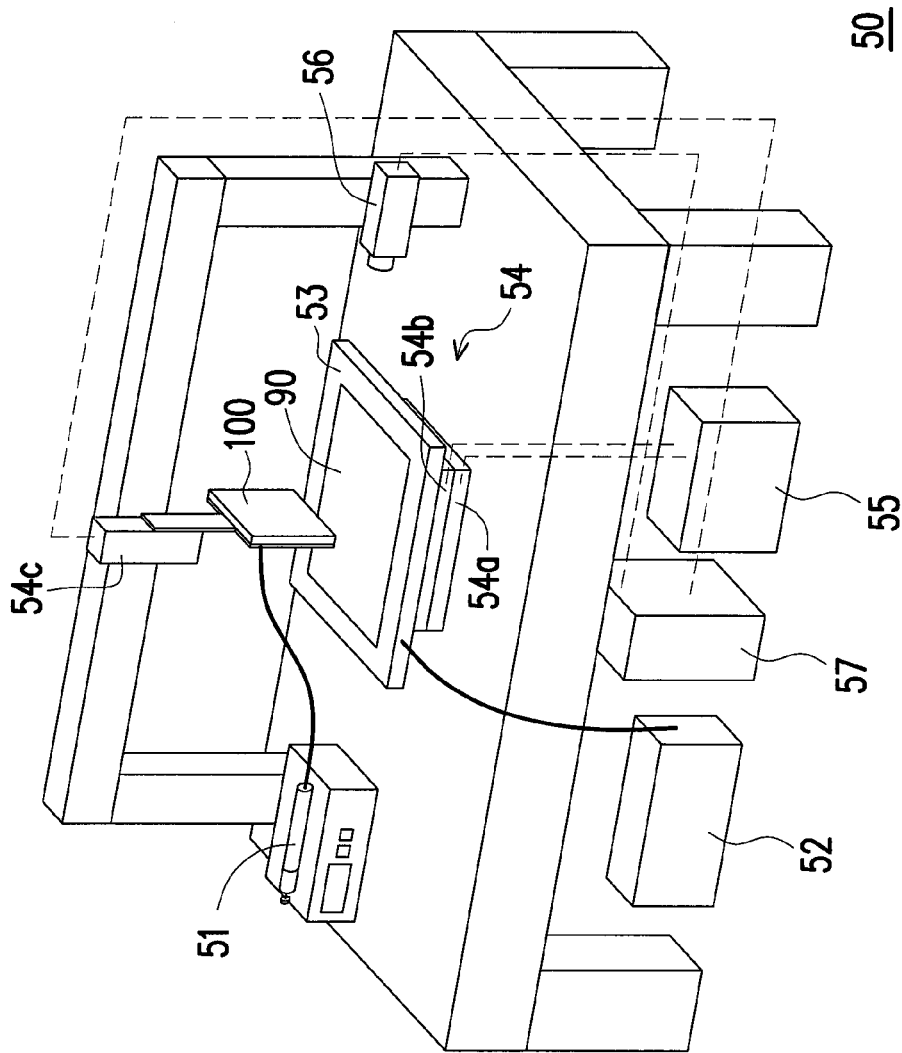

FIG. 1

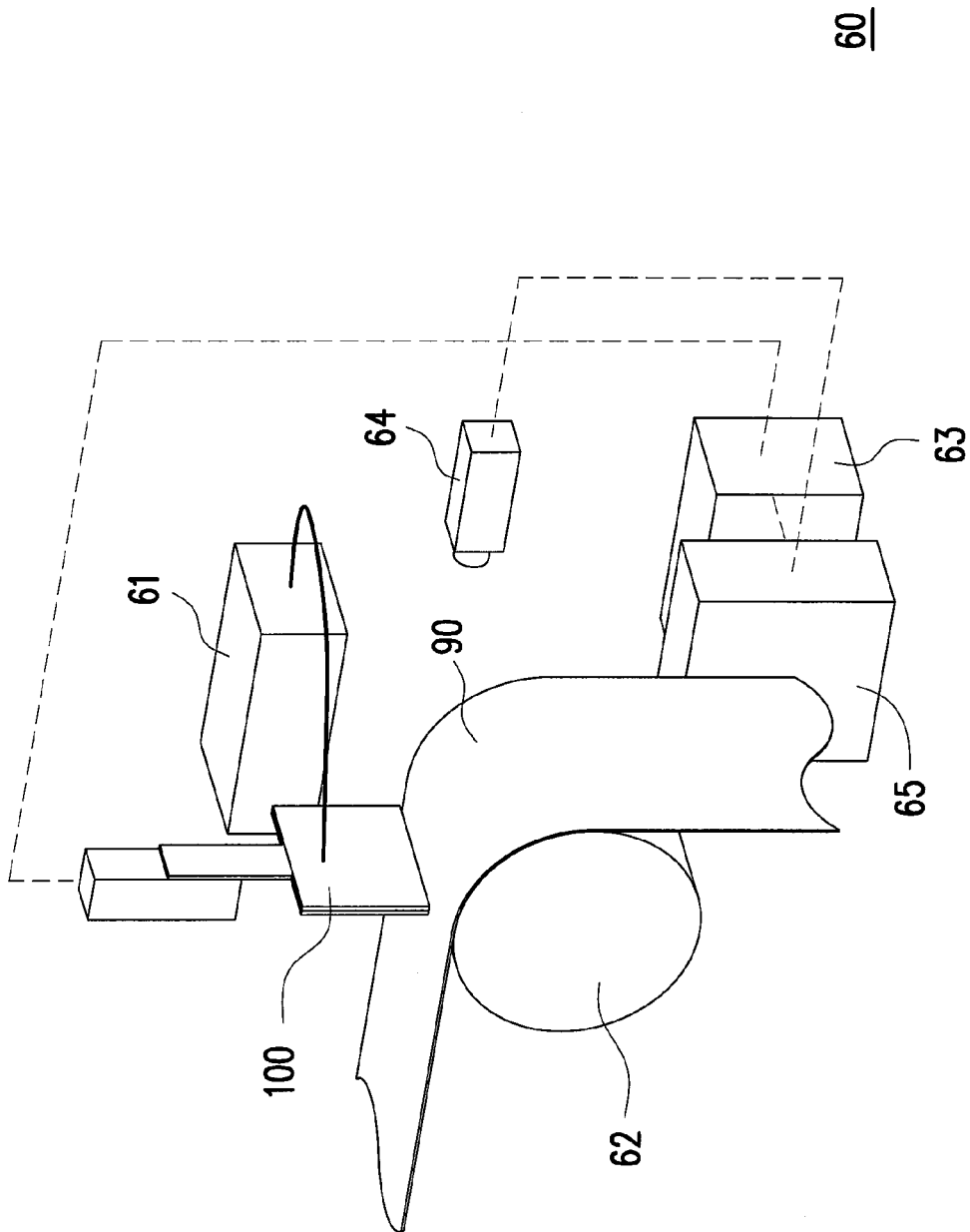
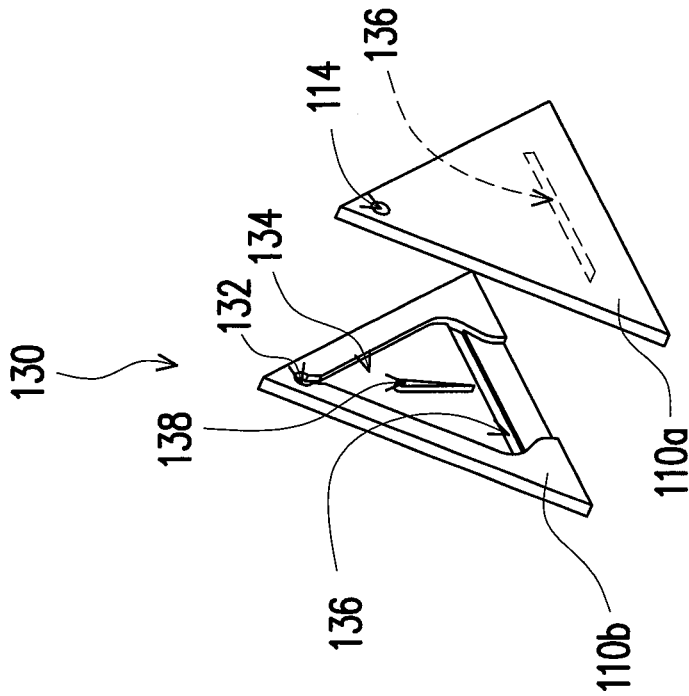

FIG. 2

60



100

FIG. 3A

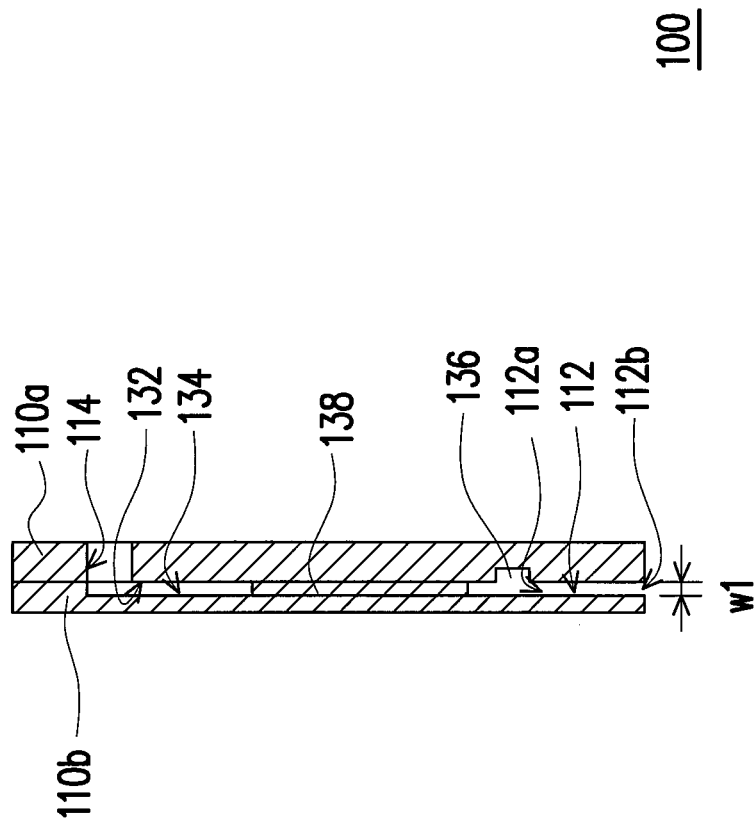

FIG. 3B

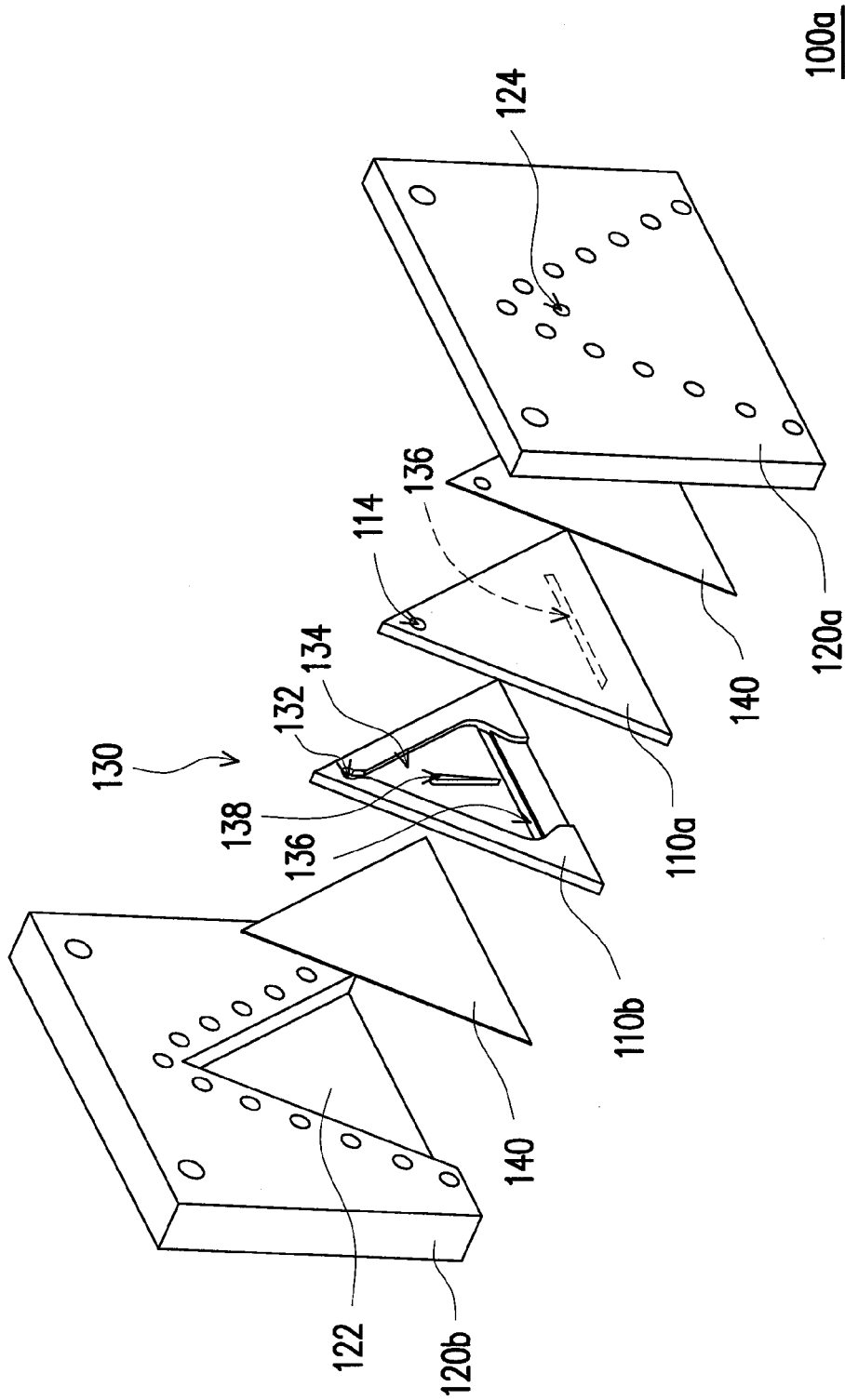

FIG. 4A

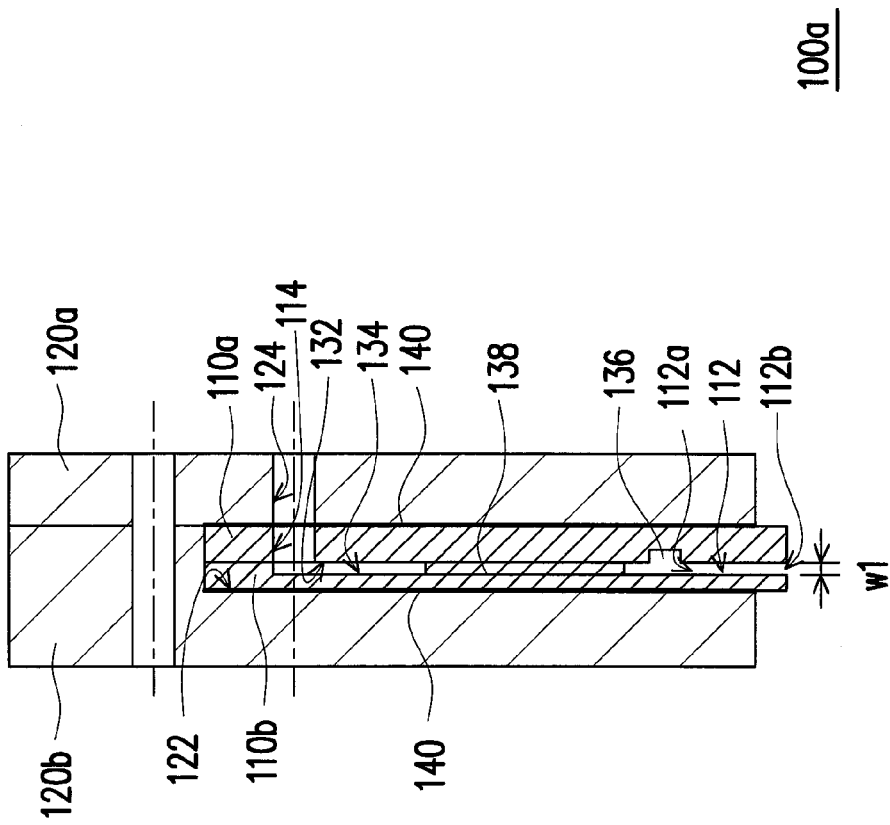

FIG. 4B

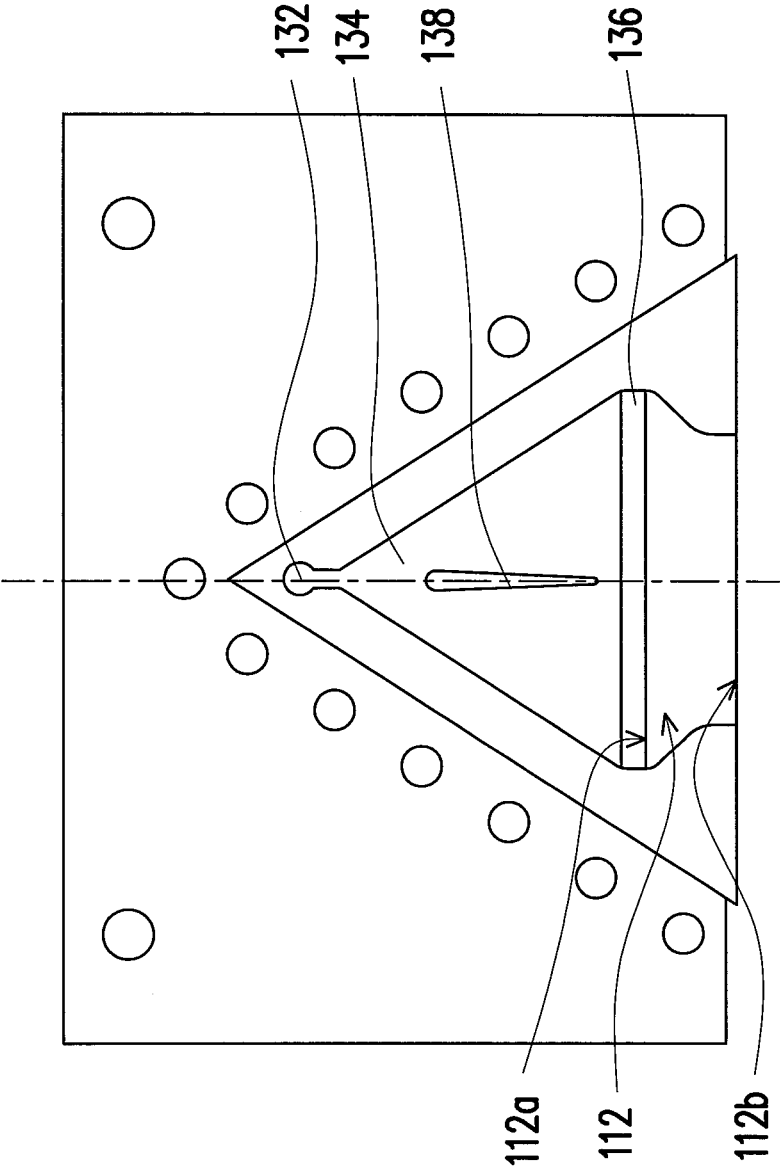

FIG. 5

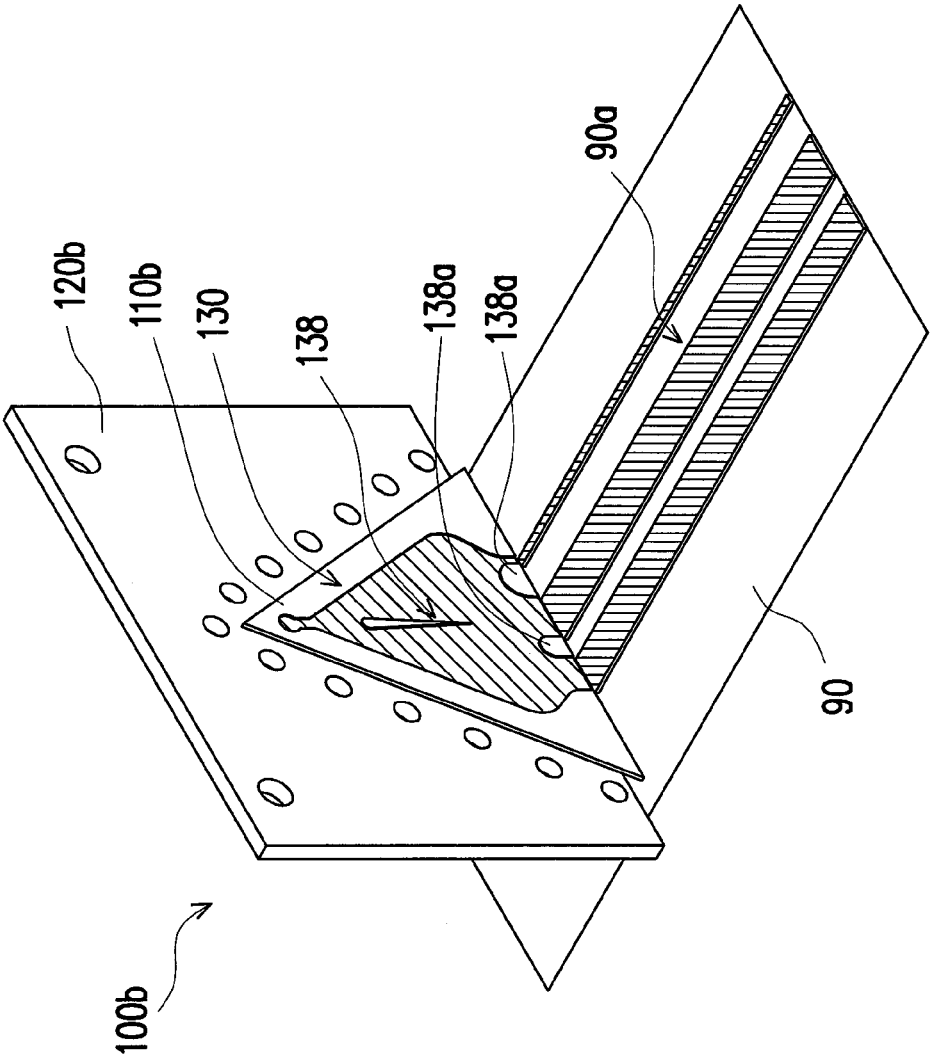

FIG. 6

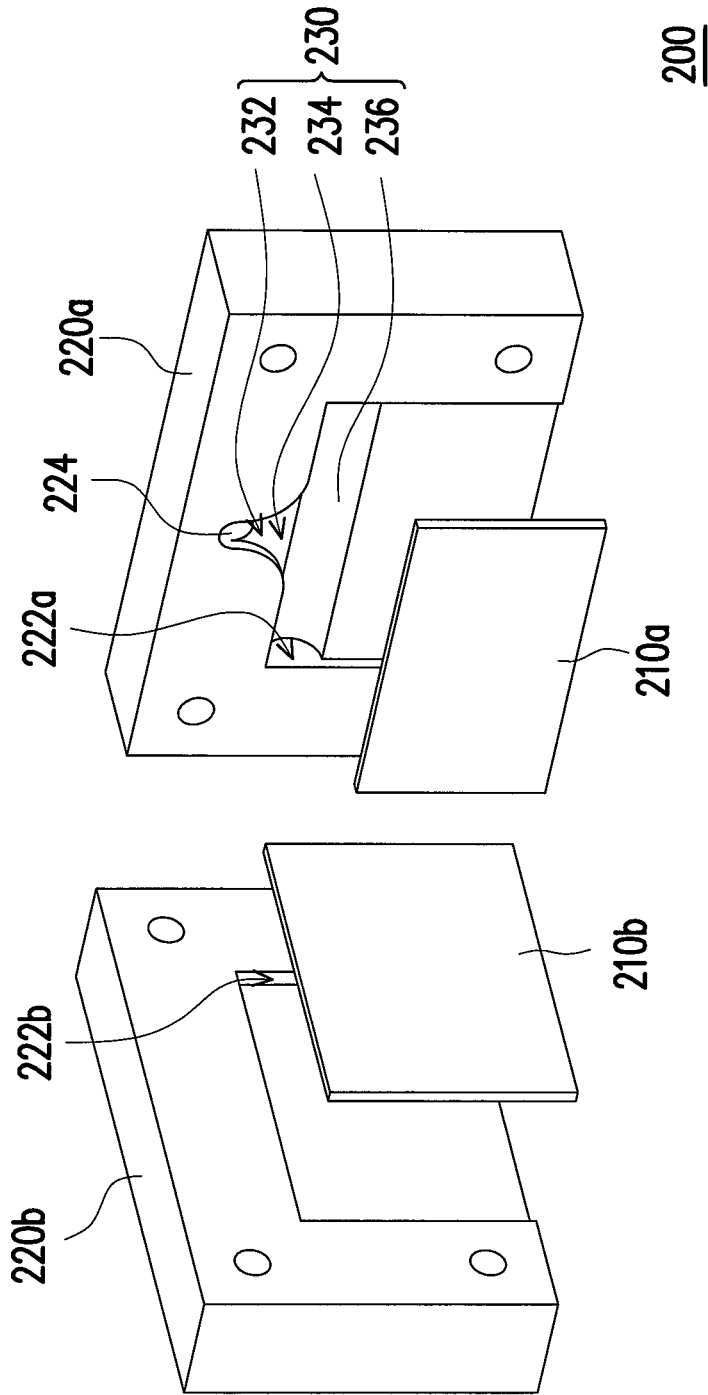

FIG. 7

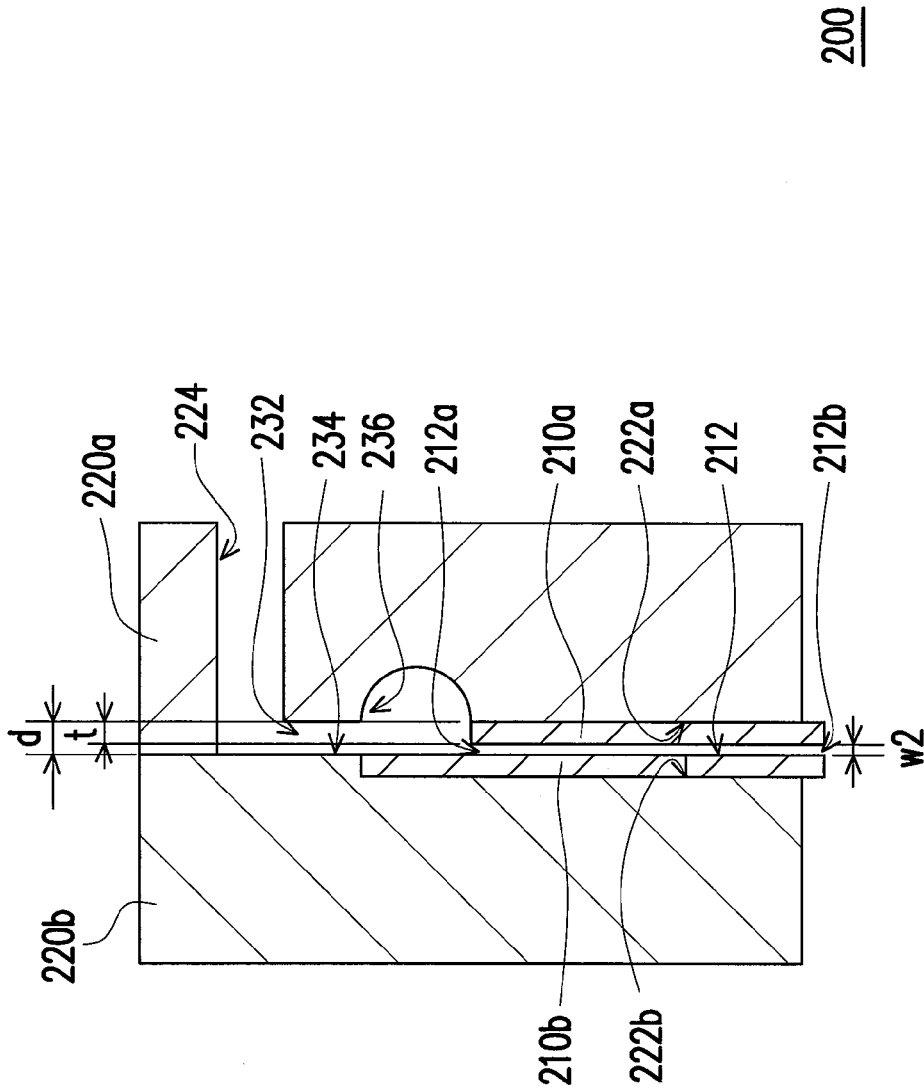

FIG. 8

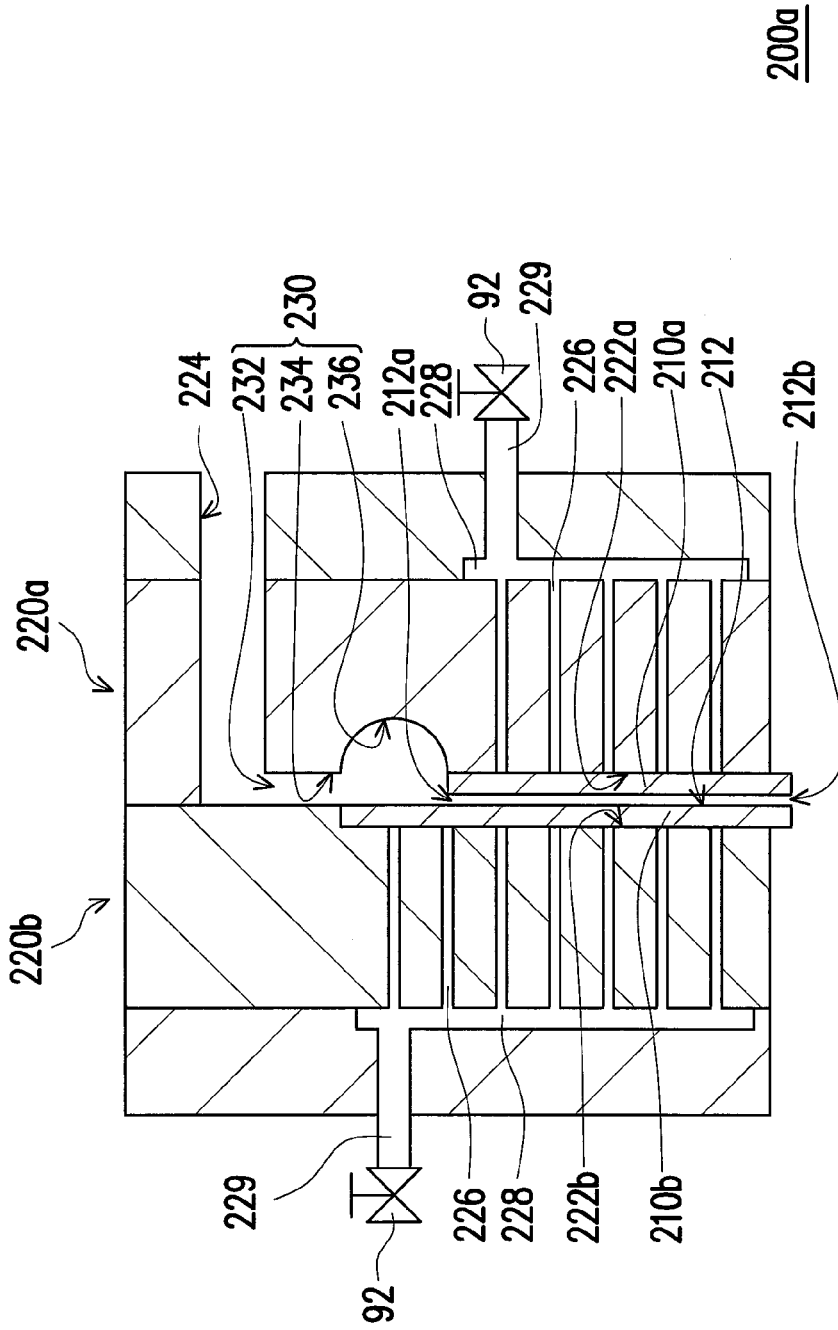

FIG. 10

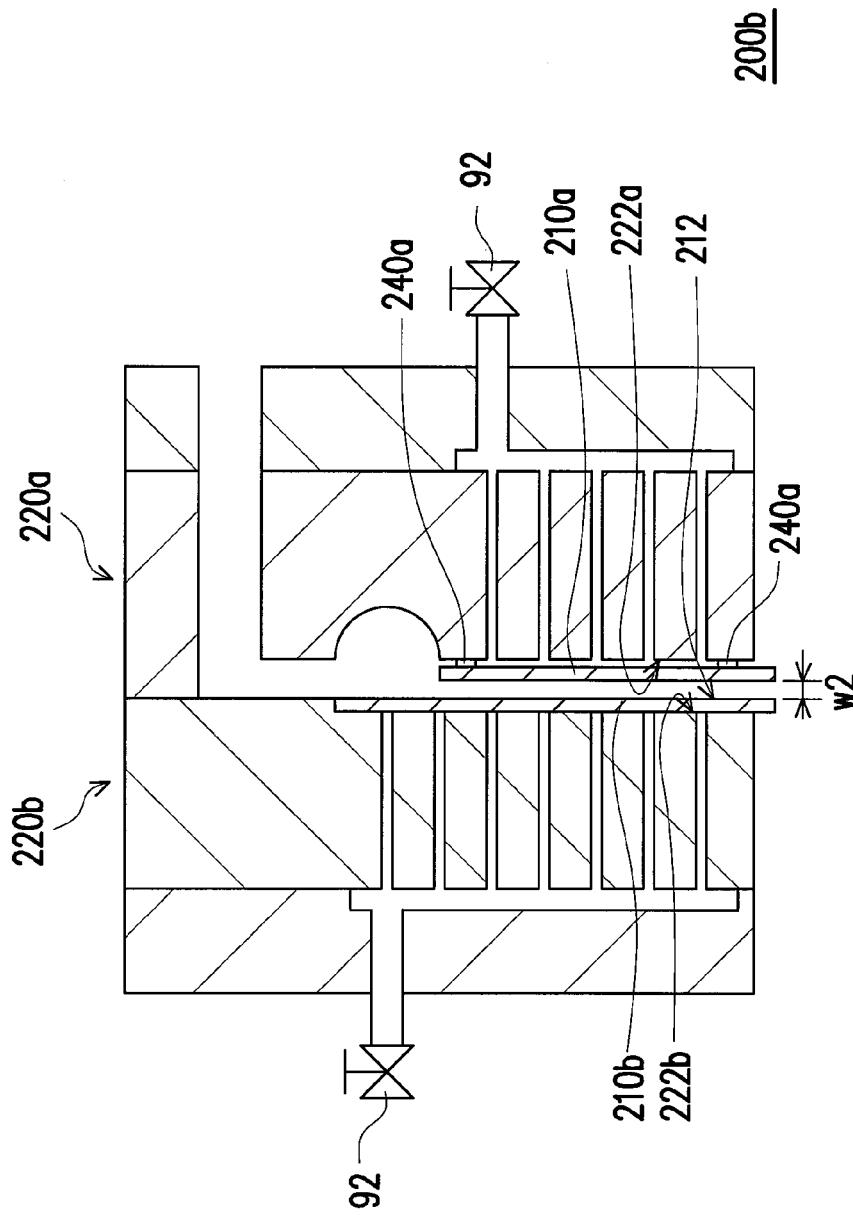

FIG. 11

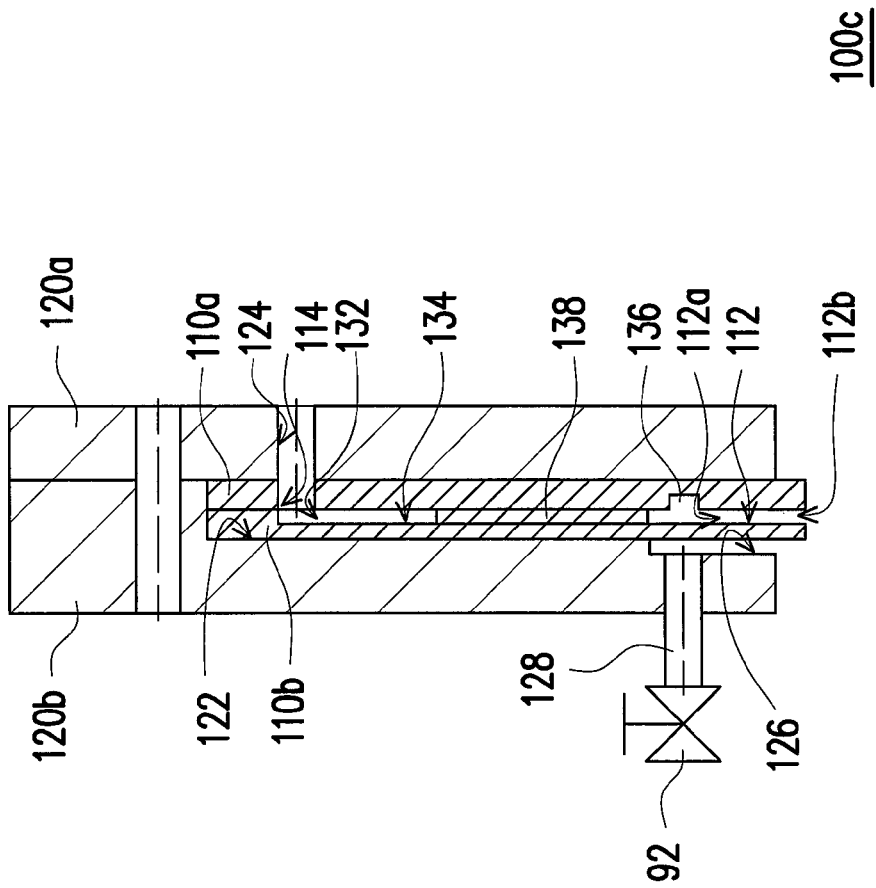
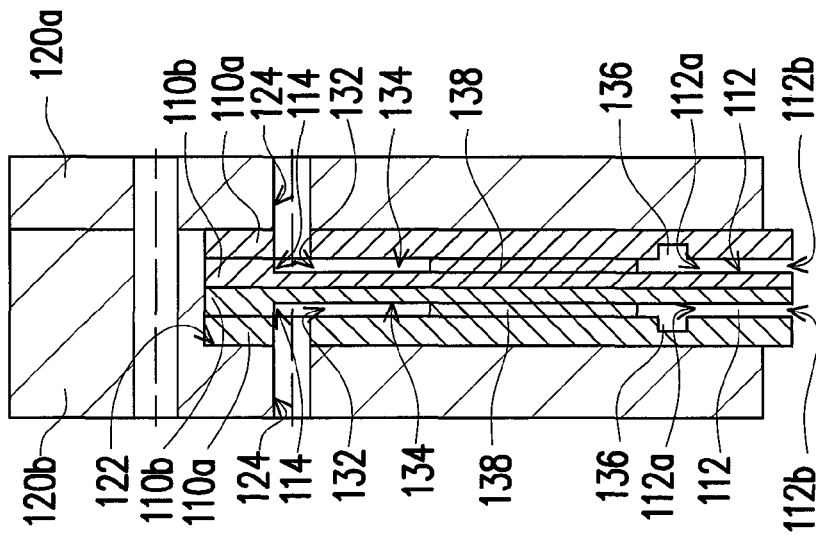

FIG. 12



100d

FIG. 13

1

COATING MODULE

CROSS-REFERENCE TO RELATED APPLICATION

This application claims the priority benefit of Taiwan application serial no. 101123480, filed on Jun. 29, 2012. The entirety of the above-mentioned patent application is hereby incorporated by reference herein and made a part of this specification.

BACKGROUND

1. Field of the Disclosure

The disclosure generally relates to a coating module, and more particularly, to a coating module able to change the plates thereof.

2. Description of Related Art

In recent years, in industrial processes, a coating device is often used to perform film-coating process, for example to form a raw strip on a ceramic capacitor or to coat optical protection film on a substrate. Taking a slot-type coating device as an example, the slot-type coating device is suitable for a film-coating process of large area. The coating device has a restrictor, and liquid is conveyed into the coating device by a measuring pump, and then outflows from a slot outlet of the coating device. The measuring pump can provide a stable supply of liquid. Therefore, the degree of uniformity for the coating liquid of the coating device will depend on the smoothness of the surface of the restrictor.

The coating device is generally formed by using two stainless steel modules to hold a shim. The shim has a restrictor and a diversion structure connecting the restrictor thereon, in which the diversion structure is, for example, a flow channel or a manifold so as to guide the liquid into the restrictor. The diversion structure mainly includes three types: T-die type structure, fishtail type structure and coat-hanger type structure. The processing and fabrication of the T-die type structure are more easily and able to make the flow rate of the liquid uniformly distributed, but the liquid is easy to form residue at the end of the manifold. The fishtail type structure enables the liquid to be uniformly spread in the flow channel, but the liquid is easy to form a recirculation zone in the diversion structures to affect the flow rate. The coat-hanger type structure can reduce the problems for the T-die type structure and the fishtail type structure to respectively produce the residue zone or the recirculation zone, but they are disadvantageous in complicated design and higher production cost. Therefore, the film-coating process usually employs a coating device with different diversion structure according to the coating liquid characteristic and the coating method, which makes a coating device very difficult to be shared for different film-coating processes.

On the other hand, in order to uniformly coating with a liquid by a coating device, the surface of the shim used to form the diversion structure and the restrictor, particularly the surface of the restrictor, must have high smoothness. Therefore, the shim requires lapping and polishing to increase the surface smoothness thereof. And, if the shim has a diversion structure with more complicate design, the shim needs for additional machining on each processing surface followed by lapping and polishing, so that the liquid can flow on the shim uniformly. These processes increase the manufacturing cost of the coating device. Further, when the restrictor of such a coating device gets worn, it is necessary to replace the shim to ensure the uniformity of the coating

2

fluid. Thus, such a coating device has higher manufacturing costs, which accordingly indirectly increases the production cost of the products by using these coating devices for film-coating process.

SUMMARY OF THE DISCLOSURE

Accordingly, the disclosure is directed to a coating module with lower production cost and better reusability.

The disclosure provides a coating module suitable for coating a liquid onto a substrate and includes two plates and a diversion structure, in which there is a slot between the plates, an end of the slot has a slot inlet, the other end of the slot has a slot outlet, and one of the plates has an injecting port. The diversion structure makes the injecting port communicated with the slot inlet, in which the liquid is configured to enter the diversion structure via the injecting port, then flow to the slot inlet through the diversion structure, then flow into the slot via the slot inlet, and then outflow from the slot via the slot outlet to be coated onto the substrate.

In an embodiment of the disclosure, the material of the plates includes silicon wafer or glass.

In an embodiment of the disclosure, the diversion structure includes a diversion inlet, a diversion channel and a manifold. The diversion inlet is communicated with the injecting port, the diversion channel is communicated with the diversion inlet, and the manifold makes the diversion channel communicated with the slot inlet, and the liquid is configured to uniformly flow to the slot inlet via the manifold.

In an embodiment of the disclosure, the diversion structure has a diversion pattern, and the diversion pattern is located on the diversion channel for guiding the liquid flowing on the diversion channel.

In an embodiment of the disclosure, the diversion pattern includes a shunting island and the shunting island is located at the slot outlet.

In an embodiment of the disclosure, the coating module further includes two fixtures for fixing the plates between the fixtures, in which the injecting port is located on one of the fixtures, and the diversion structure is formed by a part of one of the fixtures and makes the injecting port communicated with the slot inlet.

In an embodiment of the disclosure, each of the fixtures has a positioning groove, and the plates are detachably disposed in the positioning grooves to form the slot.

In an embodiment of the disclosure, each of the fixtures has a plurality of apertures, a vacuum chamber and a vacuum channel, the apertures are located on the positioning grooves and communicated with the vacuum chamber, the vacuum chamber is communicated with the vacuum channel, and the vacuum channel is configured to be connected to a vacuum device and respectively adsorb the plates through the vacuum device into the positioning grooves so as to form the slot.

In an embodiment of the disclosure, each of the fixtures has an elastic member, and each the elastic member is located between the corresponding plate and the corresponding positioning groove for adjusting the width of the slot.

In an embodiment of the disclosure, the diversion structure is formed by a part of one of the plates or formed together by parts of the two plates and the diversion structure makes the injecting port communicated with the slot inlet.

In an embodiment of the disclosure, the plate with the diversion structure is a micromachining plate.

3

In an embodiment of the disclosure, the coating module further includes two fixtures, for fixing the plates between the fixtures, in which one of the fixtures has a fixing groove, and the plates are detachably fixed in the fixing groove.

In an embodiment of the disclosure, the coating module further includes a sealing cushion, located between one of the plates and the corresponding fixture.

In an embodiment of the disclosure, the material of one of the plates and the corresponding fixture is transparent material to observe the flow of the liquid in the diversion structure.

In an embodiment of the disclosure, the coating module further includes a vacuum chamber, located at one of the fixtures and communicated with the fixing groove, wherein the vacuum chamber is configured to be connected to a vacuum device to form a vacuum state at the slot outlet.

In an embodiment of the disclosure, two pairs of the plates are detachably fixed in the fixing groove, so that the liquid is adapted to outflow from the slots via the slot outlets to be coated onto the substrate.

Based on the description above, in the coating module provided by the disclosure, there is a slot between two plates, and the slot has a slot inlet and a slot outlet. Two fixtures fix the plates and have an injecting port. The diversion structure makes the injecting port communicated with the slot inlet. The liquid can flow into the slot via the injecting port, the diversion structure and the slot inlet, and then, outflow from the coating module via the slot outlet. In this way, the coating module can coat the liquid onto a substrate. When the plates of the coating module get worn, the plates can be removed away from the fixtures to replace the worn ones with new plates, and thus, the coating module has lower production cost and better reusability.

In order to make the features and advantages of the present disclosure more comprehensible, the present disclosure is further described in detail in the following with reference to the embodiments and the accompanying drawings.

BRIEF DESCRIPTION OF THE DRAWINGS

FIG. 1 is a schematic diagram of a coating module used in a coating system according to an embodiment of the disclosure.

FIG. 2 is a schematic diagram of a coating module used in another coating system according to an embodiment of the disclosure.

FIG. 3A is an exploded diagram of a coating module according to an embodiment of the disclosure.

FIG. 3B is a cross-sectional diagram of the coating module of FIG. 3A after assembling.

FIG. 4A is an exploded diagram of a coating module according to another embodiment of the disclosure.

FIG. 4B is a cross-sectional diagram of the coating module FIG. 4A after assembling.

FIG. 5 is a front-view diagram of the coating module of FIG. 4A.

FIG. 6 is a schematic diagram of a coating module according to yet another embodiment of the disclosure.

FIG. 7 is an exploded diagram of a coating module according to yet another embodiment of the disclosure.

FIG. 8 is a cross-sectional diagram of the coating module of FIG. 7 after assembling.

FIG. 9 is an exploded diagram of a coating module according to yet another embodiment of the disclosure.

FIG. 10 is a cross-sectional diagram of the coating module of FIG. 9 after assembling.

4

FIG. 11 is a cross-sectional diagram of a coating module according to yet another embodiment of the disclosure.

FIG. 12 is a cross-sectional diagram of the coating module according to yet another embodiment of the disclosure.

FIG. 13 is a cross-sectional diagram of the coating module according to yet another embodiment of the disclosure.

DESCRIPTION OF THE EMBODIMENTS

FIG. 1 is a schematic diagram of a coating module used in a coating system according to an embodiment of the disclosure. Referring to FIG. 1, a coating module 100 is configured to connect to a coating system 50 so as to coat liquid (not shown) onto a substrate 90. In more details, the coating module 100 is connected to a liquid-supplying device 51 to make the liquid enter the coating module 100 from the liquid-supplying device 51. The substrate 90 is fixed on an adsorbing stage 53 by a vacuum device 52 and the adsorbing stage 53 is connected to a control system 54. The control system 54 provides three sliding stages 54a, 54b and 54c able to move respectively along three orthogonal axes to make the substrate 90 move relatively to the coating module 100.

The coating rate and coating position of the coating module 100 depends on the moving direction and speed of the adsorbing stage 53, therefore, the adsorbing stage 53 is connected to a stage controller 55 for controlling the displacement amount and displacement speed of the adsorbing stage 53. In addition, the coating system 50 further has an image-capturing system 56, and the image-capturing system 56 is connected to a computer 57 to instantly observe the interval between the coating module 100 and the substrate 90 for adjustment.

FIG. 2 is a schematic diagram of a coating module used in another coating system according to an embodiment of the disclosure. Referring to FIG. 2, the coating module 100 is configured to connect a coating system 60 to coat the liquid onto the substrate 90. In more details, the coating module 100 is connected to a liquid-supplying device 61 to make the liquid enter the coating module 100 from the liquid-supplying device 61. The substrate 90 can move relatively to the coating module 100 through a roller system 62.

The coating rate and coating position of the coating module 100 depends on the moving direction and speed of the roller system 62. Therefore, the roller system 62 is connected to a roller controller 63 to control the displacement amount and displacement speed of the roller system 62. In addition, the coating system 60 further has an image-capturing system 64, and the image-capturing system 64 is connected to a computer 65 to instantly observe the interval between the coating module 100 and the substrate 90 for adjustment.

FIG. 3A is an exploded diagram of a coating module according to an embodiment of the disclosure and FIG. 3B is a cross-sectional diagram of the coating module of FIG. 3A after assembling. Referring to FIGS. 3A and 3B, in the embodiment, the coating module 100 includes two plates 110a and 110b and a diversion structure 130. In more details, the plates 110a and 110b are disposed oppositely to each other, and there is a slot 112 between the plate 110a and the plate 110b (as shown by FIG. 3B). An end of the slot 112 has a slot inlet 112a and the other end of the slot 112 has a slot outlet 112b.

Referring to FIGS. 3A and 3B again, in the embodiment, the plate 110a has an injecting port 114, and the injecting port 114 goes through the plate 110a to make the interior and

5

the exterior of the coating module **100** communicated with each other. Thus, the liquid can be injected into the coating module **100** via the injecting port **114** and then flow out of the coating module **100** from the slot outlet **112b** through the slot **112**.

On the other hand, the diversion structure **130** is located between the injecting port **114** and the slot **112**. In the embodiment, the diversion structure **130** is formed together by a part of the plate **110a** and a part of the plate **110b** and makes the injecting port **114** communicated with the slot inlet **112a**. In other words, the diversion structure **130** is located on the plate **110a** and the plate **110b**, and the slot **112** is located at the tail ends of the plates **110a** and **110b** and communicated with the diversion structure **130**. Therefore, after the liquid enters the diversion structure **130** from the injecting port **114**, the liquid flows to the slot inlet **112a** via the diversion structure **130** on the plates **110a** and **110b**, then flows into the slot **112** via the slot inlet **112a**, and then outflows from the coating module **100** via the slot outlet **112b**.

In more details, the diversion structure **130** includes a diversion inlet **132**, a diversion channel **134** and a manifold **136**. The diversion inlet **132** is communicated with the injecting port **114**. The diversion channel **134** is communicated with the diversion inlet **132** and the manifold **136** makes the diversion channel **134** communicated with the slot inlet **112a**. In the embodiment, most part of the diversion structure **130** is located on the plate **110b**. The diversion structure **130** can be seen as a groove structure on the plane of the plate **110b**. As a result, when the two plates **110a** and **110b** are fixed by each other, for example, through anode bonding, the plate **110a** leans against the plate **110b**. At the time, the groove structure of the diversion structure **130** forms a space between the two plates **110a** and **110b** tight to each other, as shown by FIG. 3B, which makes the liquid flow in the diversion structure **130**.

In the same way, the slot **112** located at the tail ends of the plates **110a** and **110b** and communicated with the diversion structure **130** can be also seen as a groove structure on the plate **110b** and communicated with a part of the diversion structure **130** on the plate **110b**. As a result, when the two plates **110a** and **110b** lean against each other, the tail ends between the plates **110a** and **110b** form the slot **112** through the groove structure. By adjusting the depth of the groove on the plate **110b**, the coating module **100** can control the slot width w_1 of the slot **112**.

FIG. 4A is an exploded diagram of a coating module according to another embodiment of the disclosure and FIG. 4B is a cross-sectional diagram of the coating module FIG. 4A after assembling. Referring to FIGS. 4A and 4B, in the embodiment, the major difference of the coating module **100a** from the coating module **100** rests in that the coating module **100a** includes two fixtures **120a** and **120b**, and the fixtures **120a** and **120b** are disposed oppositely to each other and fix the plates **110a** and **110b** between the fixtures **120a** and **120b**, so that they are fixed by each other through a plurality of fasteners (for example, screws). In this way, the bonding between the plates **110a** and **110b** is more stable.

Referring to FIGS. 4A and 4B again, in the embodiment, the fixture **120b** has a fixing groove **122**, and the plates **110a** and **110b** can be detachably fixed in the fixing groove **122**. Thus, the fixing groove **122** can provide the positioning function for the plates **110a** and **110b** in association with fixing the plates **110a** and **110b** by the fixtures **120a** and **120b**. The fixture **120a** has an injecting port **124**, the injecting port **124** goes through the fixture **120a** and is corresponding to the injecting port **114** so as to make the

6

interior and the exterior of the coating module **100a** communicated with each other. As a result, the liquid can be injected into the coating module **100a** via the injecting port **114**, and then flow out of the coating module **100a** from the slot outlet **112b** through the slot **112**.

FIG. 5 is a front-view diagram of the coating module of FIG. 4A. It should be noted that the following depiction about the plates **110a** and **110b** and the diversion structure **130** is, for example, based on the coating module **100a**. Since the major difference between the coating module **100a** and the coating module **100** rests in whether employing the fixtures **120a** and **120b**, therefore, the following depiction about the plates **110a** and **110b** and the diversion structure **130** is suitable for the coating module **100** as well.

Referring to FIGS. 4A and 5, in the embodiment, the diversion inlet **132** and the injecting port **114** are corresponding to the injecting port **124** located on the fixture **120a**, while the slot **112** is a slim slot formed by the plane-type plates **110a** and **110b**. Thus, the diversion channel **134** and the manifold **136** between the diversion inlet **132** and the slot **112** need to uniformly disperse the liquid flowing into the diversion structure **130** from the hole-pass to a slim current, so that the liquid flowing into the diversion structure **130** can uniformly flow in the slot **112**.

In the embodiment, the diversion inlet **132** is connected to the diversion channel **134** roughly in fishtail shape to make the liquid flowing into the diversion structure **130** flow dispersedly. The manifold **136** is a groove in long bar shape corresponding to the shape of the slot inlet **112a** and is located on the plate **110b**. After the liquid flows from the diversion channel **134**, the manifold **136** can expand the liquid current to make the liquid dispersedly flow, and thus, the dispersed liquid current uniformly flows to the slim slot inlet **112a** via the manifold **136**.

In comparison with the diversion inlet **132** and the diversion channel **134**, the depth of the manifold **136** is greater than the depths of the diversion inlet **132** and the diversion channel **134**. In the embodiment, the manifold **136** is also disposed at the position on the plate **110a** corresponding to the manifold **136** of the plate **110b**. In other words, the manifold **136** is formed by two long-bar grooves on the plates **110a** and **110b** for increasing the depth of the manifold **136**. As a result, by disposing the manifold **136** with a larger depth on the plates **110a** and **110b**, the liquid flowing into the manifold **136** from the diversion channel **134** gets dispersed.

In other embodiments of the disclosure however, the manifold **136** can be disposed on one of the plates **110a** and **110b**. In other unshown embodiments of the disclosure, the whole diversion structure **130** can be located on one of the plates **110a** and **110b**, for example, on the plate **110a** only, while the diversion inlet **132** goes through the plate **110a** and is directly communicated with the injecting port **124**. At the time, the plate **110b** has no any groove thereon and it is a naked plate only. In other embodiments of the disclosure, the position of the diversion structure in the coating module is selected depending on the requirement, and the disclosure is not limited to.

Besides, in the embodiment, the diversion structure **130** has a diversion pattern **138**, which is located at the diversion channel **134**, and the diversion pattern **138** is a bar-shaped pillar located at the diversion channel **134** and protruded from the diversion channel **134** for guiding the liquid flowing on the diversion channel **134**. The disclosure does not limit the shape and the disposing or not of the diversion pattern. In the coating module, the shape of the diversion pattern can be adjusted so as to modify the flowing of the

liquid on the diversion channel **134** depending on the requirement, and it allows employing no diversion pattern at all.

In the embodiment, the plate **110a** and the corresponding fixture **120a** are made of transparent material. Thus, when the plates **110a** and **110b** are fixed between the fixtures **120a** and **120b** and the liquid flows into the diversion structure **130**, the flowing situation of the liquid in the diversion structure **130** can be observed from the exterior of the coating module **100a**, which the disclosure is not limited to.

Referring to FIG. 4A, in the embodiment, the coating module **100a** has two sealing cushions **140** respectively located between the plate **110a** and the fixture **120a** and between the plate **110b** and the fixture **120b** to avoid the liquid leaked from the space between the plate **110a** and the fixture **120a** or the space between the plate **110b** and the fixture **120b**. In other embodiments of the disclosure, it allows no sealing cushions **140** to be disposed in the coating module **100a** or only one sealing cushion **140** is employed and disposed between the plate **110a** and the fixture **120a** or between the plate **110b** and the fixture **120b**, which the disclosure is not limited to.

In the embodiment, the materials of the plates **110a** and **110b** are silicon wafer, while in other embodiments of the disclosure, the material of the plates is glass or other materials with surface roughness of nano-grade, which the disclosure is not limited to. A higher surface smoothness of the material of the plates **110a** and **110b** enables the liquid uniformly flowing in the slot **112** without the disturbance by the rough surface of the slot **112**. As a result, after the liquid flows through the manifold **136** and uniformly flows into the slot **112** from around the slot inlet **112a**, the liquid uniformly flows in the slot **112** and then uniformly outflows via around the slot outlet **112b**.

In addition, since the diversion structure **130** of the embodiment is located on the plates **110a** and **110b**, so that the plates **110a** and **110b** can be formed on the plates **110a** and **110b** made of silicon wafer by using a micromachining process (such as lithography and etching processes). In more details, taking the plate **110b** as example, first, a photoresist film is formed on the plate **110b**. Next, the required pattern of the diversion structure **130** is disposed on a mask, then the mask is used to perform exposing on the photoresist film on the plate **110b**, and finally, to perform developing on the photoresist film after exposure for patterning the photoresist film.

On the other hand, the patterned photoresist film is used as an etching mask to etch the plate **110b** so as to form a part of the diversion structure **130** on the plate **110b**. In the end, the patterned photoresist film is removed. In the same way, the rest part of the diversion structure **130** is formed on the plate **110a** by using the same micromachining process (such as lithography and etching processes), which the disclosure is not limited to.

According to the depiction above, the coating module **100** and the coating module **100a** can have different diversion structure **130** on the plates **110a** and **110b** depending on the requirement, for example, a diversion structure **130** in T-die type or in coat-hanger type, or the pattern or the arrangement of the diversion pattern **138** are modified. In order to coat different liquid by the coating module **100** and the coating module **100a** or to obtain different coating effects, the coating module **100** and the coating module **100a** are required to change the plates **110a** and **110b** having different diversion structures **130** only. In short, the coating module **100** and the coating module **100a** have higher adaptation.

FIG. 6 is a schematic diagram of a coating module according to yet another embodiment of the disclosure. In FIG. 6, only the fixture **120b** and the plate **110b** of the coating module **100b** are shown to make the figure clearer. Referring to FIG. 6, the major difference of the coating module **100b** in the embodiment from the coating module **100a** rests in that the diversion pattern **138** of the coating module **100b** has two shunting islands **138a**. The shunting islands **138a** are located at the slot outlet **112b**. When the liquid outflows from the coating module **100b** via the slot outlet **112b** for coating on the substrate **90**, the shunting islands **138a** enable the liquid forming a stripe-like film **90a**, i.e., a plurality of coating stripes. Therefore, by disposing shunting islands **138a** with different quantity at the slot outlet **112b** or adjusting the positions of the shunting islands **138a**, the coating module **100b** is able to coat a stripe-like film with different stripe quantity and different stripe interval.

When the substrate **90** requires to be coated with liquid having different properties thereon, or to obtain different coating effects, for example, to form the stripe-like film, the coating module **100** is required to change the plates **110a** and **110b** having different diversion structures **130** only. In addition, when the plates **110a** and **110b** with higher surface smoothness get damage due to the flowing of the liquid molecules, the plates **110a** and **110b** can be removed away from the fixing groove **122** and they are replaced by new plates **110a** and **110b**. At the time, to handle the surface wearing problem of the slot **112** in the coating module **100**, only the plates **110a** and **110b** need to be replaced without replacing the whole coating module **100**, which makes the coating module **100** have lower production cost and better reusability.

FIG. 7 is an exploded diagram of a coating module according to yet another embodiment of the disclosure and FIG. 8 is a cross-sectional diagram of the coating module of FIG. 7 after assembling. Referring to FIGS. 7 and 8, in the embodiment, a coating module **200** includes two plates **210a** and **210b**, two fixtures **220a** and **220b** and a diversion structure **230**. The plates **210a** and **210b** are disposed oppositely to each other and there is a slot **212** between the plate **210a** and the plate **210b** (as shown by FIG. 8). An end of the slot **212** has a slot inlet **212a** and the other end of the slot **212** has a slot outlet **212b**.

The fixtures **220a** and **220b** are disposed oppositely to each other and fix the plates **210a** and **210b** between the fixtures **220a** and **220b**, in which the fixtures **220a** and **220b** have a plurality of fastening holes (for example, thread holes) thereon, so that the fixtures **220a** and **220b** are fastened by each other through a plurality of fasteners (for example, screws).

In the embodiment, the fixtures **220a** and **220b** respectively have a positioning groove **222a** and a positioning groove **222b**, and the plates **210a** and **210b** are respectively detachably disposed in the positioning grooves **222a** and **222b** correspondingly. In more details, the plate **210a** is detachably disposed in the positioning groove **222a**, the plate **210b** is detachably disposed in the positioning groove **222b**, and the plates **210a** and **210b** keep opposite to each other. Thus, when the fixtures **220a** and **220b** fix the plates **210a** and **210b**, the positioning grooves **222a** and **222b** can make the plates **210a** and **210b** positioned.

Referring to FIG. 8, in the embodiment, the positioning groove **222a** has groove depth d , the plate **210a** has plate thickness t and the groove depth d of the positioning groove **222a** is greater than the plate thickness t of the plate **210a**. In addition, in the embodiment, the surface of the plate **210b**

is flush with the surface of the fixture **220b** outside the positioning groove **222b**, which the disclosure is not limited to. So, when the plates **210a** and **210b** are respectively disposed at the corresponding positioning grooves **222a** and **222b**, the plate **210a** is entirely located in the positioning groove **222a** and the plate **210b** is entirely located in the positioning groove **222b**. When the two fixtures **220a** and **220b** are fixed by each other, the fixture **220a** leans against the fixture **220b**, but the plate **210a** does not lean against the plate **210b**. In this way, the slot **212** is formed between the plate **210a** and the plate **210b** through the dimension difference between the groove depth *d* and the plate thickness *t*.

On the other hand, the slot **212** has slot width *w2*. When the plates **210a** and **210b** are respectively disposed in the corresponding positioning grooves **222a** and **222b** to form the slot **212** between the plates **210a** and **210b**, the slot width *w2* depends on the dimension difference between the groove depth *d* and the plate thickness *t*. In this way, the slot width *w2* of the slot **212** in the coating module **200** can be controlled by adjusting the dimension difference between the groove depth *d* and the plate thickness *t*.

Referring to FIGS. 7 and 8, in the embodiment, the fixture **220a** has an injecting port **224**, and the injecting port **224** goes through the fixture **220a** and is communicated with the interior and exterior of the coating module **200**. Thus, the liquid can be injected into the coating module **200** via the injecting port **224** and then flow out of the coating module **200** from the slot outlet **212b** through the slot **212**.

On the other hand, the diversion structure **230** is located between the injecting port **224** and the slot **212**. In the embodiment, the diversion structure **230** is formed by a part of the fixture **220a** and makes the injecting port **224** communicated with the slot inlet **212a**. After the liquid enters the diversion structure **230** from the injecting port **224**, the liquid flows to the slot inlet **212a** via the diversion structure **230** on the fixture **220a**, then flows into the slot **212** via the slot inlet **212a**, and then outflows from the coating module **200** via the slot outlet **212b**.

In more details, the diversion structure **230** includes a diversion inlet **232**, a diversion channel **234** and a manifold **236**. The diversion inlet **232** is communicated with the injecting port **224**. The diversion channel **234** is communicated with the diversion inlet **232**. The manifold **236** makes the diversion channel **234** communicated with the slot inlet **212a**. In the embodiment, the diversion structure **230** is located on the fixture **220a** and makes the injecting port **224** communicated with the slot inlet **212a** through being communicated with the positioning groove **222a** located on the same fixture **220a**. In other words, the diversion structure **230** is a groove structure located on the plane of the fixture **220a**. When the fixture **220a** leans against the fixture **220b**, the groove structure of the diversion structure **230** forms a space between the fixture **220a** and the fixture **220b** tight to each other, so that the liquid is able to flow in the diversion structure **230**.

Referring to FIG. 7 again, in the embodiment, the diversion inlet **232** is an open hole located on the fixture **220a** and corresponding to the injecting port **224**, while the slot **212** is a slim slot formed by the plane-type plates **210a** and **210b**. As a result, the diversion channel **234** and manifold **236** located between the diversion inlet **232** and the slot **212** need to uniformly disperse the liquid entering the diversion structure **230** from the hole-pass to a slim current, so that the liquid entering the slot **212** can uniformly flow in the slot **212**.

In more details, in the embodiment, the diversion inlet **232** is connected to the diversion channel **234** roughly in fishtail shape so that the liquid entering the diversion inlet **232** can dispersedly flow. The manifold **236** is a groove with a long-bar shape corresponding to the shape of the slot inlet **212a** and is located in the positioning groove **222a**. The length of the plate **210a**, thus, is less than the length of the plate **210b**. The plate **210a** links up the bottom of the manifold **236** (as shown by FIG. 7) to make the manifold **236** communicated with the slot inlet **212a**. After the liquid outflows from the diversion channel **234**, the manifold **236** makes the liquid expanded and dispersed so that the dispersedly flowing liquid uniformly flow to the slim slot inlet **212a** via the manifold **236**.

In comparison with the diversion inlet **232** and the diversion channel **234**, the depth of the manifold **236** is greater than the depths of the diversion inlet **232** and the diversion channel **234**. In short, by disposing the manifold **236** with larger depth on the fixture **220a**, the liquid flowing into the manifold **236** from the diversion channel **234** becomes dispersed.

In the embodiment, the materials of the plates **210a** and **210b** are silicon wafer, while in other embodiments of the disclosure, the material of the plates is glass or other materials with surface roughness of nano-grade, which the disclosure is not limited to. A higher surface smoothness of the material of the plates **210a** and **210b** enables the liquid flowing in the slot **212** without the disturbance by the rough surface of the slot **212**. As a result, after the liquid flows through the manifold **236** and uniformly flows into the slot **212** from around the slot inlet **212a**, the liquid uniformly flows in the slot **212** and then uniformly outflows via around the slot outlet **212b**.

In the embodiment, the plates **210a** and **210b** are adhered into the corresponding positioning groove **222a** and positioning groove **222b** through adhesive or other adhering ways. Thus, the plates **210a** and **210b** are fixed in the positioning groove **222a** and the positioning groove **222b** in adhering way. In order to remove out the plates **210a** and **210b** from the positioning groove **222a** and the positioning groove **222b**, an appropriate solvent is used. It should be noted that the adhesive for adhering the plates **210a** and **210b** should not react with the liquid flowing in the coating module **200** to avoid the adhesive from failure to make the plates **210a** and **210b** separated after the liquid flows into the coating module **200**.

FIG. 9 is an exploded diagram of a coating module according to yet another embodiment of the disclosure and FIG. 10 is a cross-sectional diagram of the coating module of FIG. 9 after assembling. In yet another embodiment of the disclosure, the plates **210a** and **210b** in the coating module **200a** are adsorbed to the positioning groove **222a** and the positioning groove **222b** by a vacuum device **92**, so that the plates **210a** and **210b** are fixed and disposed in the corresponding positioning groove **222a** and positioning groove **222b**.

In more details, the fixtures **220a** and **220b** of the coating module **200a** respectively have a plurality of apertures **226**, a vacuum chamber **228** and a vacuum channel **229**. Taking the fixture **220a** as an example, the apertures **226** are located on the positioning groove **222a** and communicated with the vacuum chamber **228**. The vacuum chamber **228** is communicated with the vacuum channel **229**. The vacuum channel **229** is communicated with the exterior of the fixture **220a** and connected to the vacuum device **92**. In the same way, the fixture **220b** is communicated with the exterior of

11

the fixture **220b** and connected to the vacuum device **92** via the apertures **226**, the vacuum chamber **228** and the vacuum channel **229**.

In order to simplify the fabrications of the apertures **226**, the vacuum chamber **228** and the vacuum channel **229**, in the embodiment, each of the fixtures **220a** and **220b** can be divided into two portions for individual fabrication. For the fixture **220a** as an example, the fixture **220a** is divided into two fixing modules. The positioning groove **222a** is located on the fixing module close to the plate **210a** and at a side of the fixing module facing the plate **210a**, and the apertures **226** go through the fixing module until the other side of the fixing module from the positioning groove **222a**. The vacuum chamber **228** and the vacuum channel **229** are located on the other fixing module far away from the plate **210a**, and the vacuum chamber **228** and the vacuum channel **229** are together make the opposite two sides of the fixing module communicated with each other (as shown by FIG. 9). Thus, when the two fixing modules are joined to form the fixture **220a**, the apertures **226**, the vacuum chamber **228** and the vacuum channel **229** are communicated with each other to enable the plate **210a** adsorbed in the positioning groove **222a** by the vacuum device **92**.

In the same way, the plate **210b** can be adsorbed in the positioning groove **222b** by the vacuum device **92**. The disclosure does not limit the above-mentioned fabrication method of the fixture **220a** that a fixture is divided into two fixing modules, the apertures **226**, the vacuum chamber **228** and the vacuum channel **229** are disposed at the two different fixing modules and then, the two fixing modules are joined to form the fixture **220a**. In addition, when the vacuum device **92** is turned off, the plates **210a** and **210b** can be removed away from the positioning groove **222a** and the positioning groove **222b**, which the disclosure is not limited to. In other embodiments of the disclosure, the plates can be detachably disposed in the positioning grooves in other ways.

FIG. 11 is a cross-sectional diagram of a coating module according to yet another embodiment of the disclosure. In other embodiments of the disclosure, the fixtures **220a** and **220b** of a coating module **200b** can have two elastic members **240a** and **240b** disposed respectively between the corresponding plate **210a** and positioning groove **222a** and between the corresponding plate **210b** and positioning groove **222b**, or the elastic member is disposed at one of the sides. In FIG. 11, only one elastic member **240a** is disposed between the plate **210a** and the positioning groove **222a**, which the disclosure is not limited to. At the time, the elastic member **240a** is disposed between the plate **210a** and the positioning groove **222a**.

When the vacuum device **92** respectively adsorbs the plates **210a** and **210b** into the corresponding positioning grooves **222a** and **222b**, the elastic force of the elastic member **240a** makes the plate **210a** not tight to the positioning groove **222a**. Accordingly, once the coefficient of elasticity of the elastic member **240a** is appropriate, the slot width w_2 of the slot **212** can be adjusted. In addition, the disclosure does not limit the quantity of the elastic members and the quantity and the disposing positions of the elastic members in the coating module **200b** can be selected depending on the requirement.

In the coating module **200** and **200a** and **200b**, the plates **210a** and **210b** can be fixed in the positioning grooves **222a** and **222b** and removed away from the positioning grooves **222a** and **222b**. When the plates **210a** and **210b** with higher surface smoothness get worn due to the flowing of the liquid molecules, the plates **210a** and **210b** can be removed away

12

from the positioning grooves **222a** and **222b** and they are replaced by new plates **210a** and **210b**. At the time, to handle the surface wearing problem of the slot **212** in the coating module **200** or **200a** or **200b**, only the plates **210a** and **210b** need to be replaced without replacing the whole coating module **200** or **200a** or **200b**, which makes the coating module **200** and **200a** and **200b** have lower production cost and better reusability.

FIG. 12 is a cross-sectional diagram of the coating module according to yet another embodiment of the disclosure. Referring to FIG. 12, the major difference of the coating module **100c** in the embodiment from the coating module **100a** rests in that the coating module **100c** further includes a vacuum chamber **126**, located at fixture **120b** and communicated with the fixing groove **122**. The description of the structures and functions of the plates **110a** and **110b** and the fixtures **120a** and **120b** of the coating module **100c** can refer the description about coating module **100a** in FIG. 4A and FIG. 4B and FIG. 5.

In more details, the vacuum chamber **126** is communicated with the fixing groove **122** and correspondingly located near the slot outlet **112b**. The vacuum chamber **126** is configured to be connected to the vacuum device **92**. When the vacuum device **92** is operated, the region near the slot outlet **112b** of the slot **112** form a vacuum state, so as to thin the liquid flowed out from the slot **112** via the slot outlet **112b** and coated onto the substrate, but operating the vacuum device **92** or not does not limit thereto, the user can operate the vacuum device **92** according to the needs.

FIG. 13 is a cross-sectional diagram of the coating module according to yet another embodiment of the disclosure. Referring to FIG. 13, the major difference of the coating module **100d** in the embodiment from the coating module **100a** rests in that the coating module **100d** includes two pairs of the plates **110a** and **110b**. The description of the structures and functions of the plates **110a** and **110b** and the fixtures **120a** and **120b** of the coating module **100d** also can refer the description about coating module **100a** in FIG. 4A and FIG. 4B and FIG. 5.

In more details, the two pairs of the plates **110a** and **110b** are detachably fixed in the fixing groove **122**, and the fixtures **120b** also has an injecting port **124**. Each injecting port **124** goes through the fixture **120a** and **120b** and is corresponding to the injecting port **114** of each pair of the plates **110a** and **110b** respectively, so that the liquid is adapted to outflow from two slots **112** to be coated onto the substrate. More specifically, the liquid can be injected into the coating module **100d** via the two injecting port **114**, and then flow out of the coating module **100d** from the slot outlets **112b** through the slots **112** of the two pair of the plates **110a** and **110b**. As the result, the coating module **100d** can coat two layers of liquid on the substrate, wherein the two layers of the liquid may be different material. Similarly, the coating module in other embodiment may include multiple pairs of the plates **110a** and **110b** detachably fixed in the fixing groove **122**, so as to coat multiple layers with different liquid on the substrate, and it does not limit thereto.

Therefore, when the plates **110a** and **110b** of the coating module **100c** and **100d** with higher surface smoothness get damage due to the flowing of the liquid molecules, the plates **110a** and **110b** can be removed away from the fixing groove **122** and they are replaced by new plates **110a** and **110b**. At the time, to handle the surface wearing problem of the slot **112** in the coating module **100c** and **100d**, only the plates **110a** and **110b** need to be replaced without replacing the

13

whole coating module **100c** and **100d**, which makes the coating module **100c** and **100d** have lower production cost and better reusability.

In summary, in the coating module provided by the disclosure, there is a slot between two plates, and the slot has a slot inlet and a slot outlet. Two fixtures fix the plates and have an injecting port. The diversion structure makes the injecting port communicated with the slot inlet. The liquid can flow into the coating module via the injecting port, then flow into the slot via the diversion structure and the slot inlet, and then, outflow from the slot outlet so as to coat the liquid onto a substrate. In addition, the plates are detachably disposed in the grooves of the fixtures. When the surface of the slot gets worn, the plates can be removed away from the fixtures to replace the worn ones with new plates, without changing the whole coating module. In addition, the coating module can have different diversion structure depending on the requirement. In order to coat different liquid by the coating module and or to obtain different coating effects, the coating module is required to change the plates having different diversion structures only. Therefore, the coating module has higher adaptation, lower production cost and better reusability.

It will be apparent to those skilled in the art that the descriptions above are several preferred embodiments of the disclosure only, which does not limit the implementing range of the disclosure. Various modifications and variations can be made to the structure of the disclosure without departing from the scope or spirit of the disclosure. The claim scope of the disclosure is defined by the claims hereinafter.

What is claimed is:

1. A coating module, suitable for coating a liquid onto a substrate, comprising:

a planar slot consisting of: two plates, wherein the planar slot is constructed only by the two plates therebetween with two plane surfaces in parallel, an end of the slot has a slot inlet, the other end of the slot has a slot outlet, and one of the two plates has an injecting port, wherein the material of the two plates comprises silicon wafer or glass; and

a curved diversion structure, connecting the injecting port and the slot inlet with at least one curved periphery from the injecting port to the planar slot, wherein the liquid is configured to enter the diversion structure via the injecting port, then uniformly flow to the slot inlet through the diversion structure, then flow into the slot via the slot inlet, and then uniformly outflow from the slot via the slot outlet, so that the liquid flows from a hole and disperses as a thin film through the curved diversion structure to directly form a thin film through the planar slot to be coated onto the substrate.

2. The coating module as claimed in claim **1**, wherein the diversion structure comprises:

a diversion inlet, communicated with the injecting port; a diversion channel, communicated with the diversion inlet; and

a manifold, making the diversion channel communicated with the slot inlet, and the liquid is configured to uniformly flow to the slot inlet via the manifold.

3. The coating module as claimed in claim **2**, wherein the diversion structure has a diversion pattern, and the diversion

14

pattern is located on the diversion channel for guiding the liquid flowing on the diversion channel.

4. The coating module as claimed in claim **3**, wherein the diversion pattern comprises a shunting island, and the shunting island is located at the slot outlet.

5. The coating module as claimed in claim **1**, further comprising:

two fixtures, fixing the two plates between the two fixtures, wherein the injecting port is located on one of the two fixtures, and the diversion structure is formed by a part of one of the two fixtures and makes the injecting port communicated with the slot inlet.

6. The coating module as claimed in claim **5**, wherein each of the two fixtures has a positioning groove, and the two plates are detachably disposed in the positioning grooves to form the slot.

7. The coating module as claimed in claim **6**, wherein each of the two fixtures has a plurality of apertures, a vacuum chamber and a vacuum channel, the apertures are located on the positioning grooves and communicated with the vacuum chamber, the vacuum chamber is communicated with the vacuum channel, and the vacuum channel is configured to be connected to a vacuum device and respectively adsorb the two plates through the vacuum device into the positioning grooves so as to form the slot.

8. The coating module as claimed in claim **6**, wherein each of the two fixtures has an elastic member, and each the elastic member is located between the corresponding plate and the corresponding positioning groove for adjusting the width of the slot.

9. The coating module as claimed in claim **1**, wherein the diversion structure is formed by a part of one of the two plates or formed together by parts of the two plates, and the diversion structure makes the injecting port communicated with the slot inlet.

10. The coating module as claimed in claim **9**, wherein one of the two plate with the diversion structure is a micromachined plate.

11. The coating module as claimed in claim **9**, further comprising:

two fixtures, fixing the two plates between the two fixtures, wherein one of the two fixtures has a fixing groove, and the two plates are detachably fixed in the fixing groove.

12. The coating module as claimed in claim **11**, further comprising:

a sealing cushion, located between one of the two plates and the corresponding one of the two fixtures.

13. The coating module as claimed in claim **11**, wherein material of one of the two plates and the corresponding fixture thereof is transparent material to observe the flow of the liquid in the diversion structure.

14. The coating module as claimed in claim **11**, further comprising:

a vacuum chamber, located at one of the two fixtures and communicated with the fixing groove, wherein the vacuum chamber is configured to be connected to a vacuum device to form a vacuum state at the slot outlet.

15. The coating module as claimed in claim **11**, wherein two pairs of the two plates are detachably fixed in the fixing groove, so that the liquid is adapted to outflow from the slots via the slot outlets to be coated onto the substrate.

* * * * *