



US009991602B2

(12) **United States Patent**
Wu et al.

(10) **Patent No.:** **US 9,991,602 B2**
(45) **Date of Patent:** **Jun. 5, 2018**

(54) **FREQUENCY REFLECTING UNIT**

USPC 342/1, 2, 3, 4
See application file for complete search history.

(71) Applicant: **NATIONAL TAIWAN UNIVERSITY,**
Taipei (TW)

(56) **References Cited**

(72) Inventors: **Tzong-Lin Wu,** Taipei (TW); **Yi-Min Yu,** New Taipei (TW)

U.S. PATENT DOCUMENTS

(73) Assignee: **NATIONAL TAIWAN UNIVERSITY,**
Taipei (TW)

2005/0146402 A1* 7/2005 Sarabandi H01P 1/2005
333/219
2009/0079637 A1* 3/2009 Fukui H01Q 1/241
343/700 MS

(*) Notice: Subject to any disclaimer, the term of this patent is extended or adjusted under 35 U.S.C. 154(b) by 342 days.

FOREIGN PATENT DOCUMENTS

TW 1318851 B 12/2009
TW 1333829 B 11/2010

(21) Appl. No.: **14/661,053**

OTHER PUBLICATIONS

(22) Filed: **Mar. 18, 2015**

Chuen-De Wang, et al., "Bandwidth Enhancement Based on Optimized Via Location for Multiple Vias EBG Power/Ground Planes", IEEE Transactions on Components, Packaging and Manufacturing Technology, pp. 332-340, vol. 2, No. 2, Feb. 2012.
Ku-Teng Hsu, et al., "Design of Reflectionless Vias Using Neural Network-Based Approach", IEEE Transactions on Advanced Packaging, pp. 211-218, vol. 31, No. 1, Feb. 2008.

(65) **Prior Publication Data**

US 2017/0040707 A1 Feb. 9, 2017

(30) **Foreign Application Priority Data**

Oct. 27, 2014 (TW) 103136981 A

* cited by examiner

(51) **Int. Cl.**

H01Q 15/00 (2006.01)
H01Q 17/00 (2006.01)
H01Q 1/52 (2006.01)
H01Q 1/42 (2006.01)

Primary Examiner — Robert Karacsony

(74) *Attorney, Agent, or Firm* — Li&Cai Intellectual Property (USA) Office

(52) **U.S. Cl.**

CPC **H01Q 15/0026** (2013.01); **H01Q 15/0013** (2013.01); **H01Q 15/0053** (2013.01); **H01Q 1/425** (2013.01); **H01Q 1/52** (2013.01); **H01Q 17/008** (2013.01)

(57) **ABSTRACT**

A frequency reflecting unit is provided. The frequency reflecting unit is used as a portion of a frequency reflector. The frequency reflecting unit with a three-dimensional structure includes a metal pattern and at least one via. The metal pattern is disposed on a metal layout layer defined on one side of the frequency reflecting unit. One end of the via is disposed corresponding to the metal pattern. The via forms a non-zero angle with the metal layout layer. The other end of the via is an open circuit.

(58) **Field of Classification Search**

CPC H01Q 15/0006; H01Q 15/0013; H01Q 15/002; H01Q 15/0026; H01Q 15/0053; H01Q 15/006; H01Q 15/0066; H01Q 15/008; H01Q 15/0086; H01Q 15/0093; H01Q 1/425; H01Q 1/52; H01Q 17/008

16 Claims, 16 Drawing Sheets

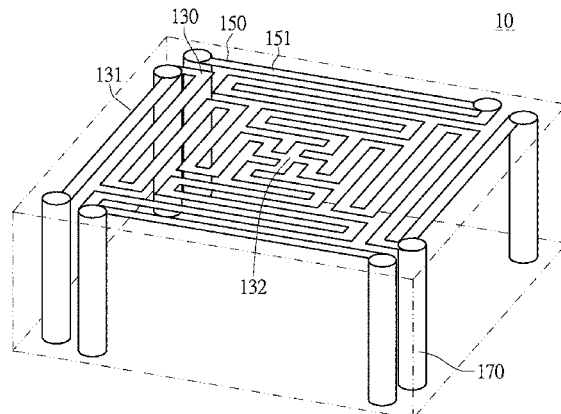

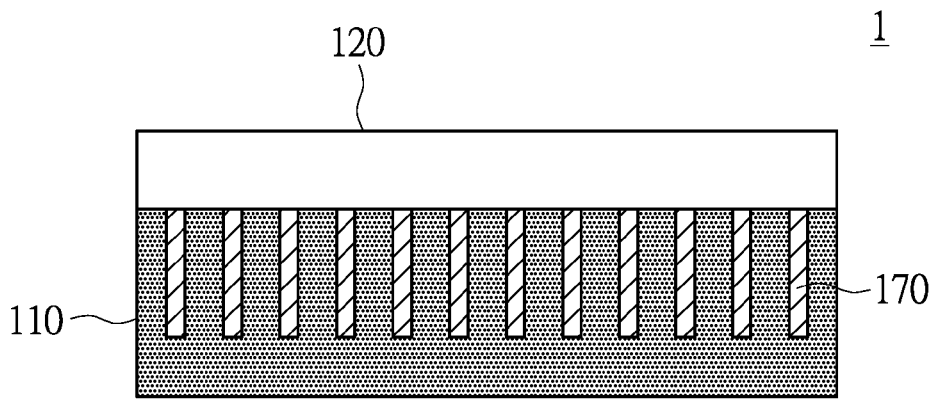

FIG. 1A

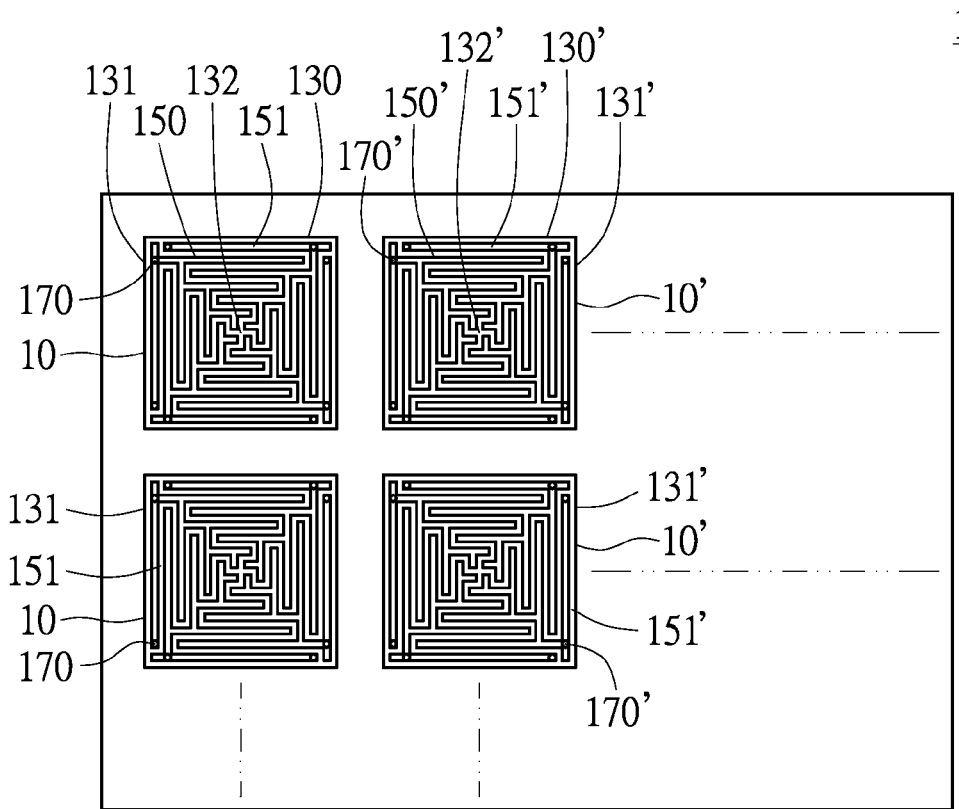

FIG. 1B

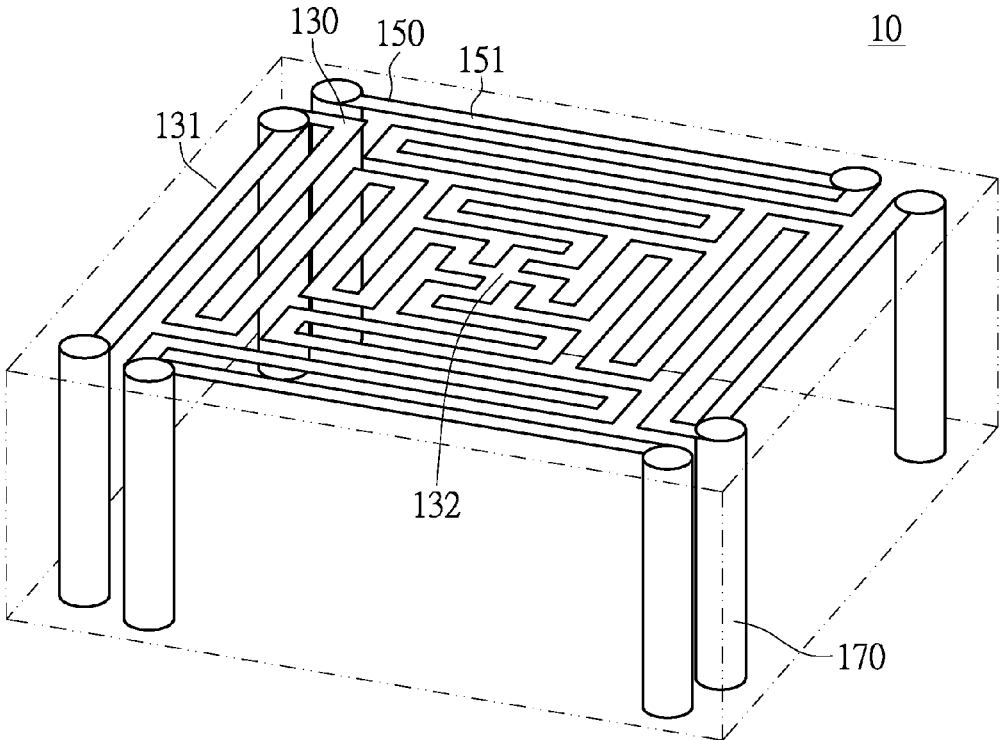

FIG.2A

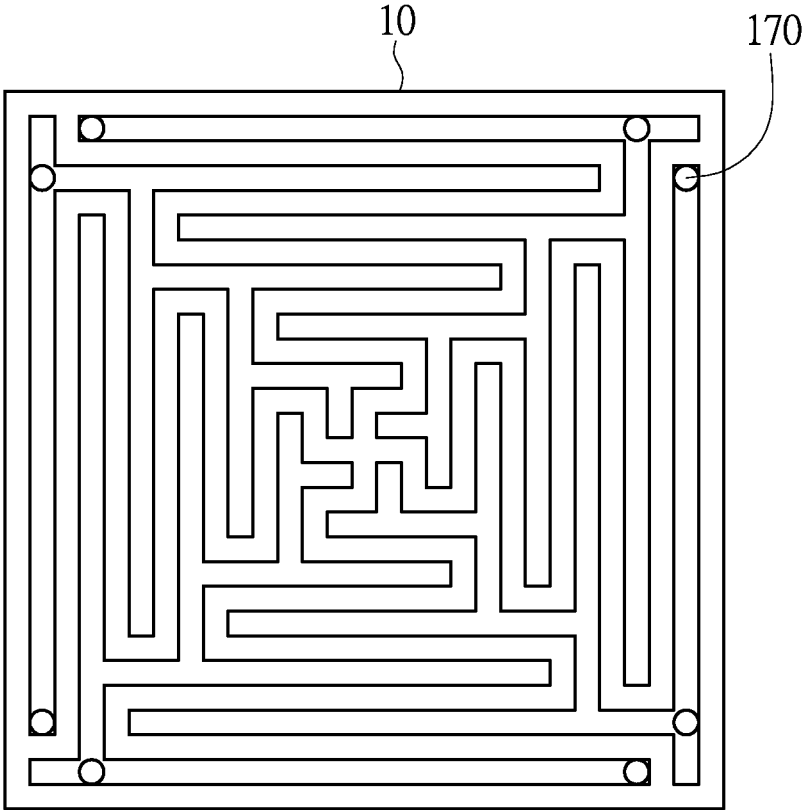

FIG. 2B

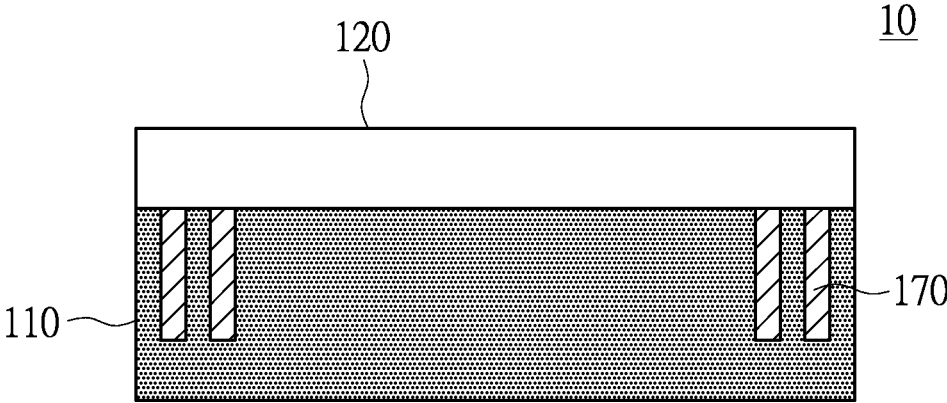

FIG. 2C

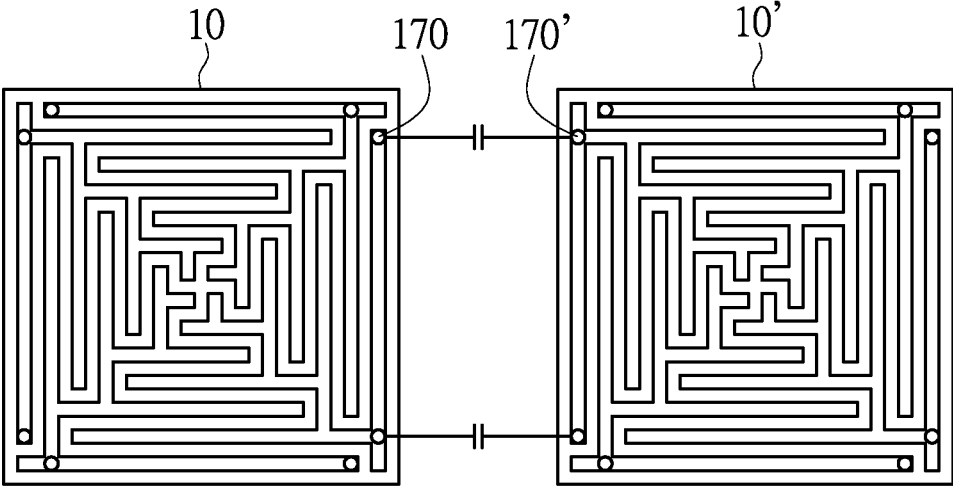

FIG.3

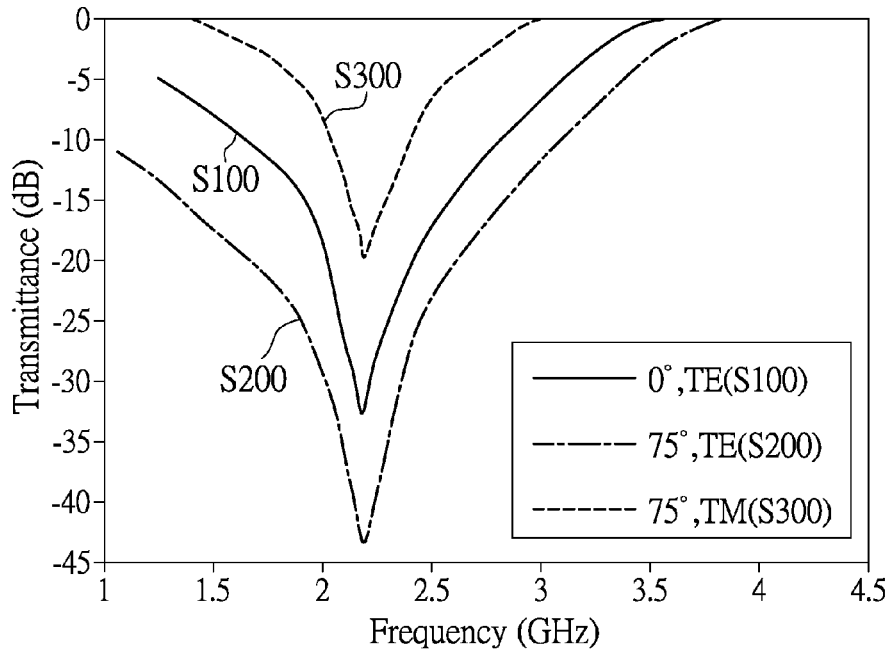

FIG.4A

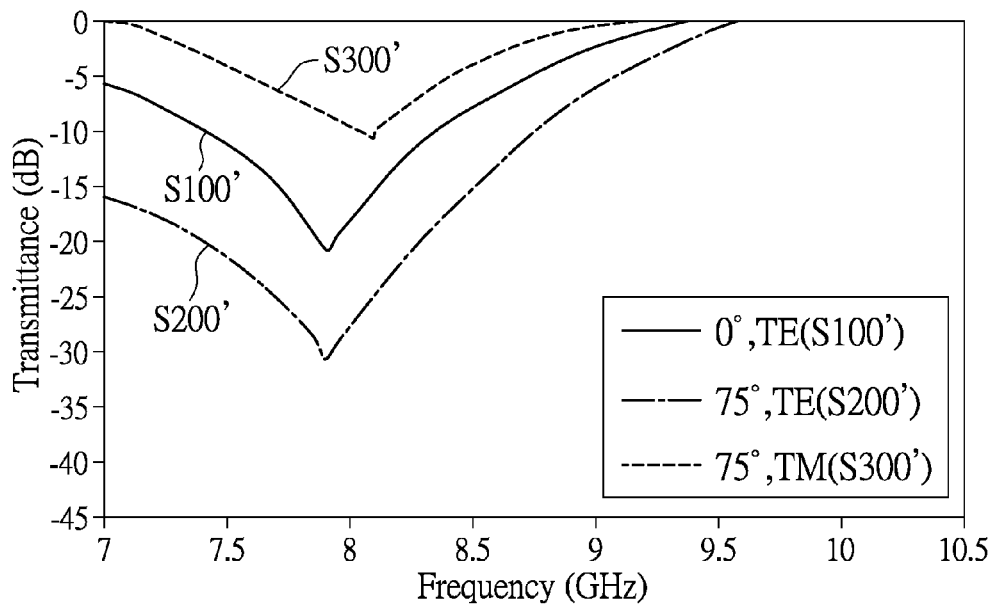

FIG.4B(PRIOR ART)

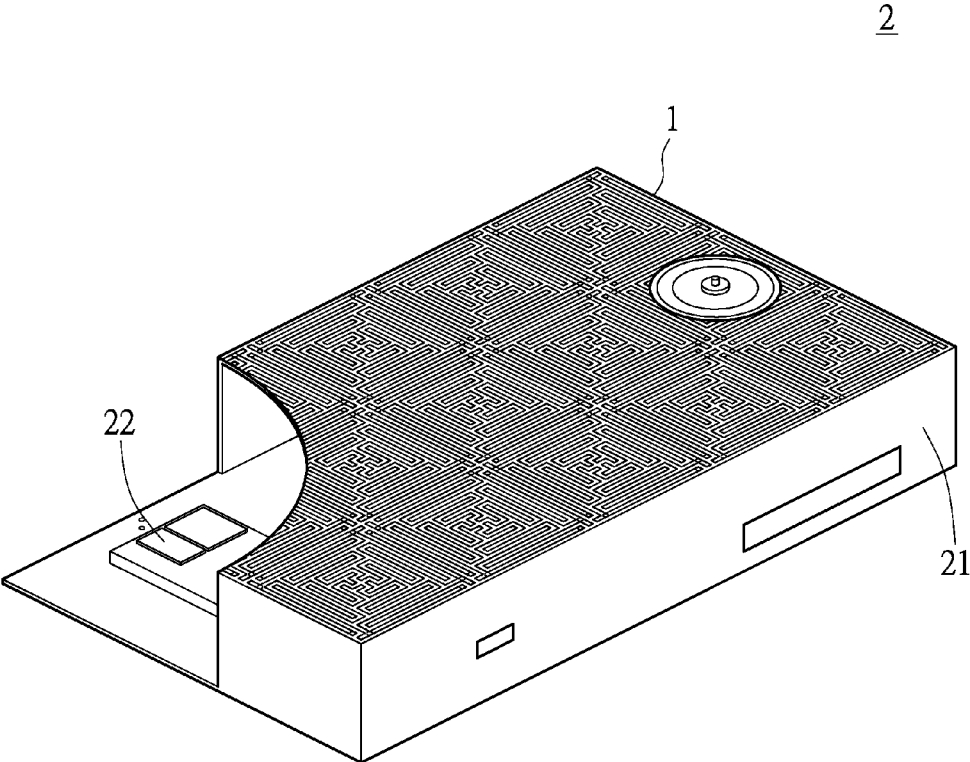

FIG.5

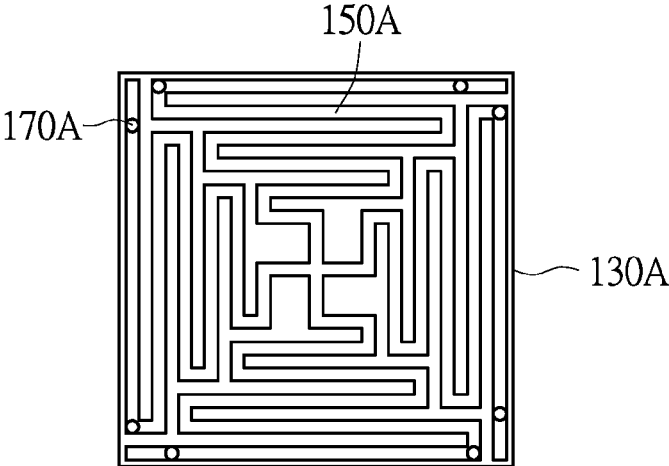

FIG.6A

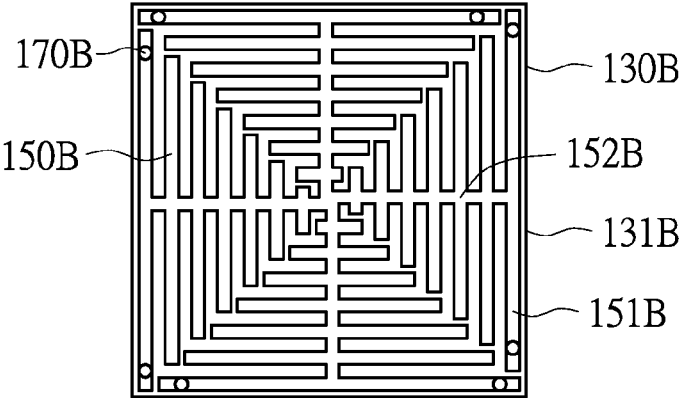

FIG.6B

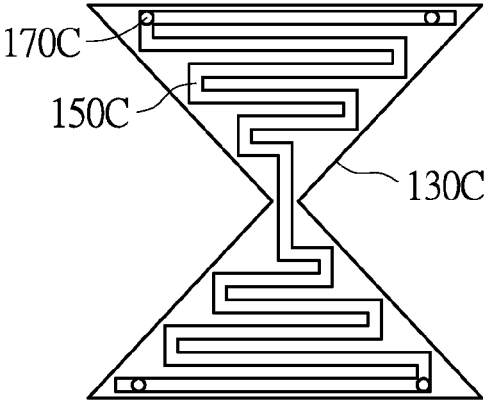

FIG.6C

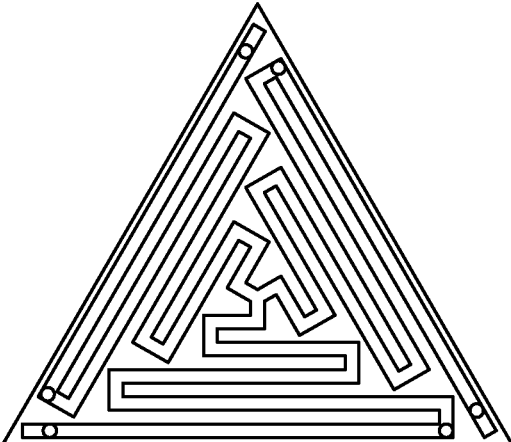

FIG.7A

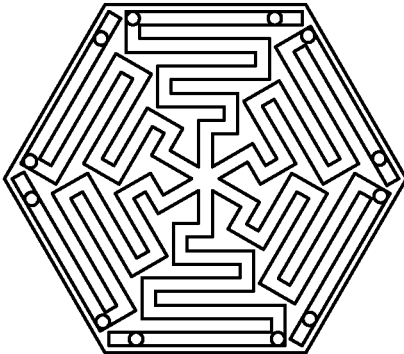

FIG.7B

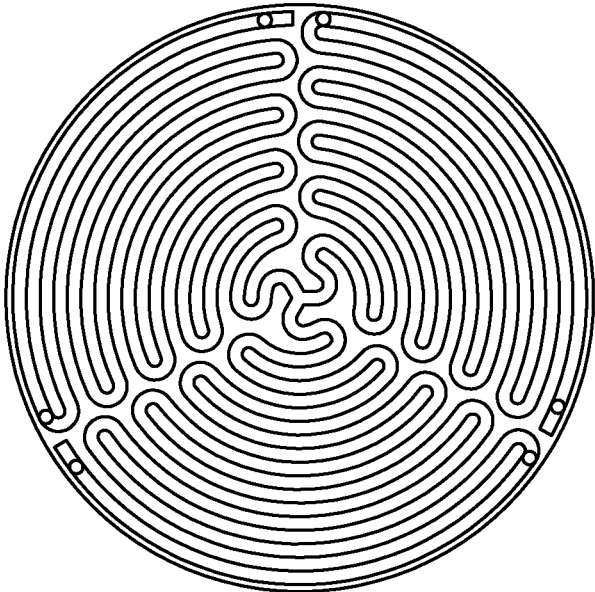

FIG.7C

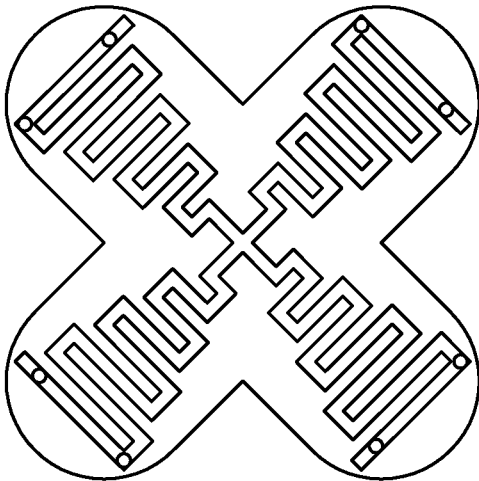

FIG.7D

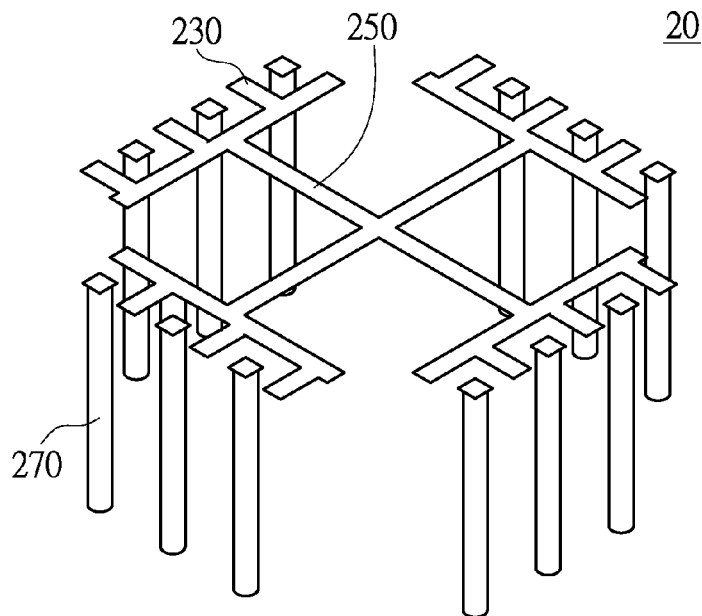

FIG. 8A

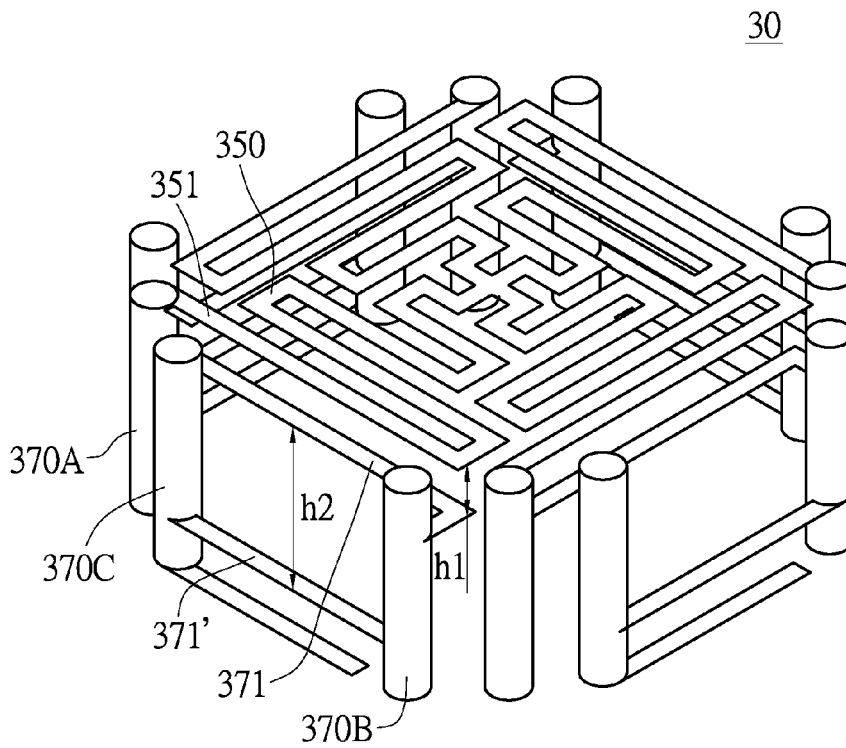

FIG. 8B

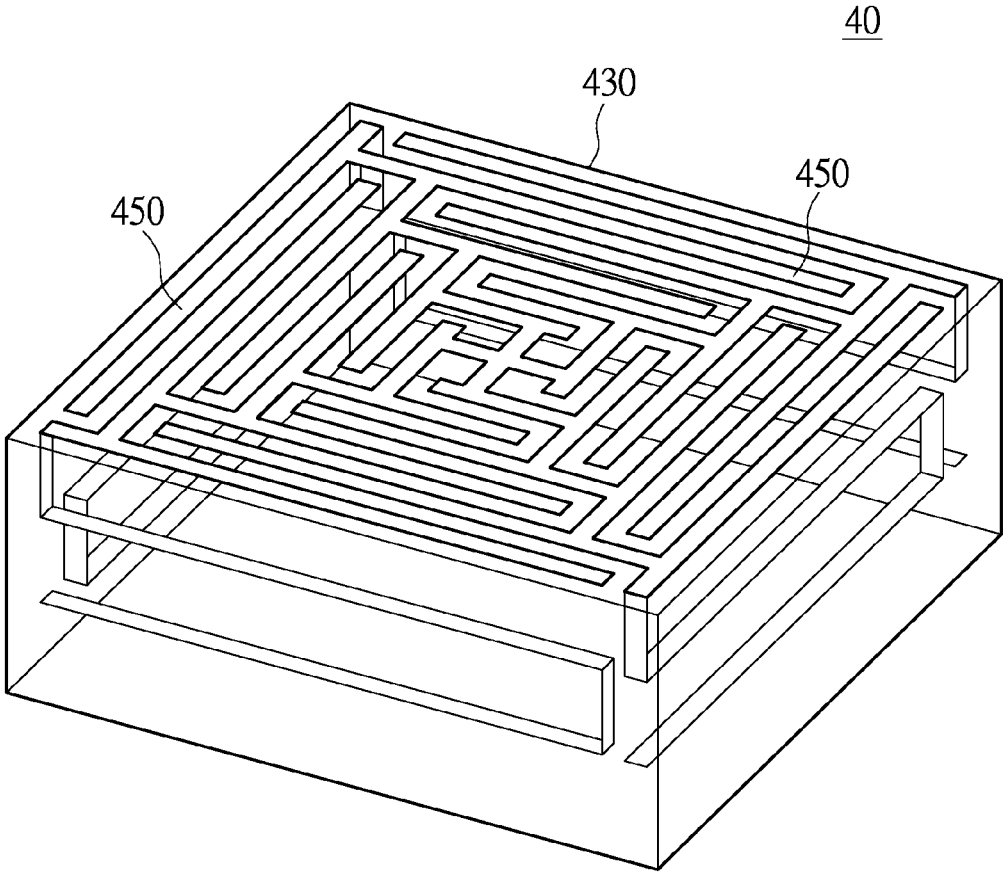

FIG.9

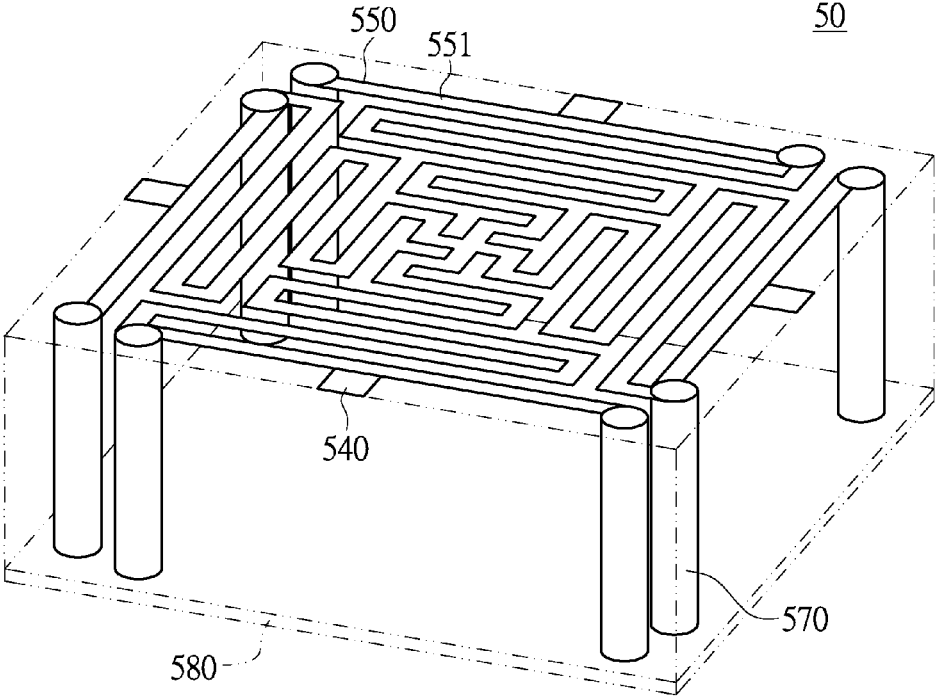

FIG.10A

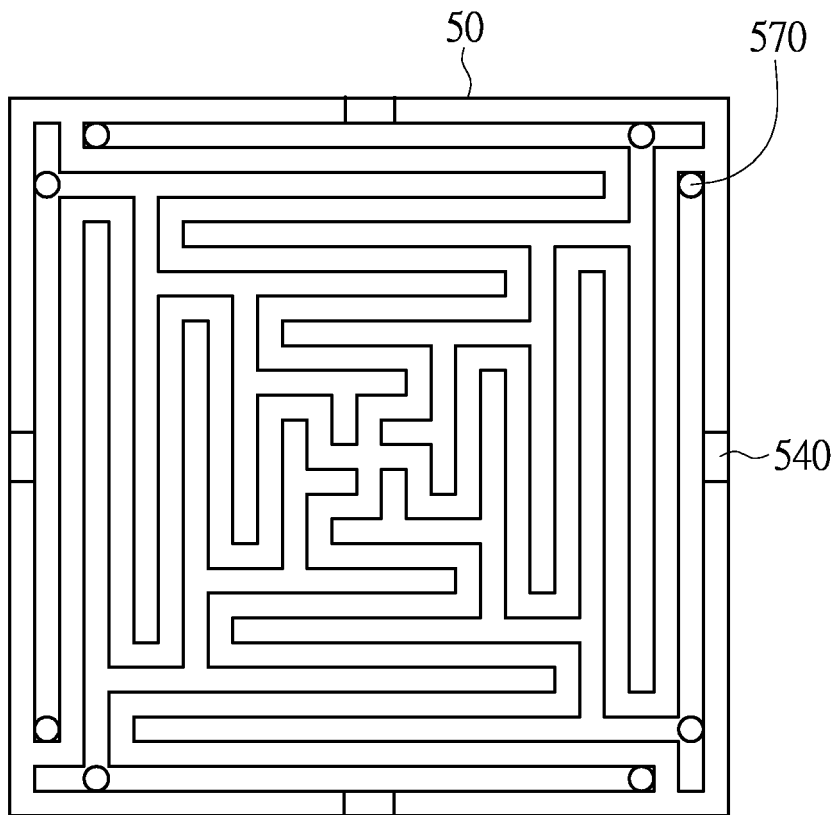

FIG. 10B

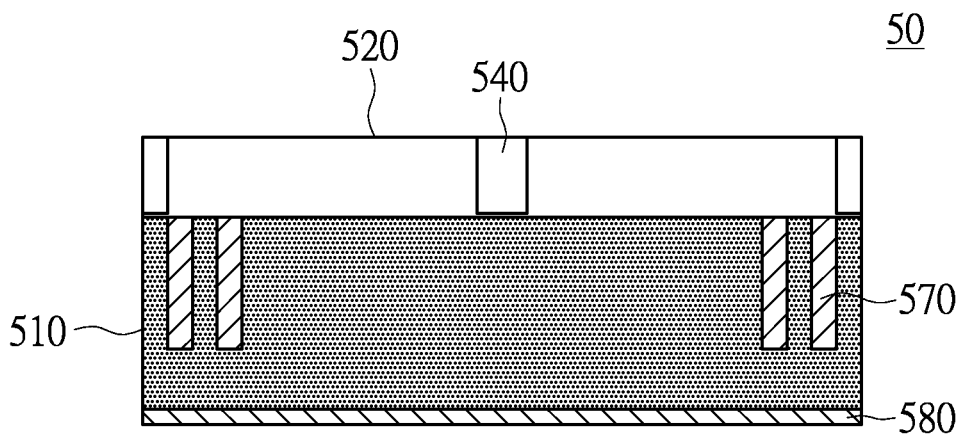

FIG. 10C

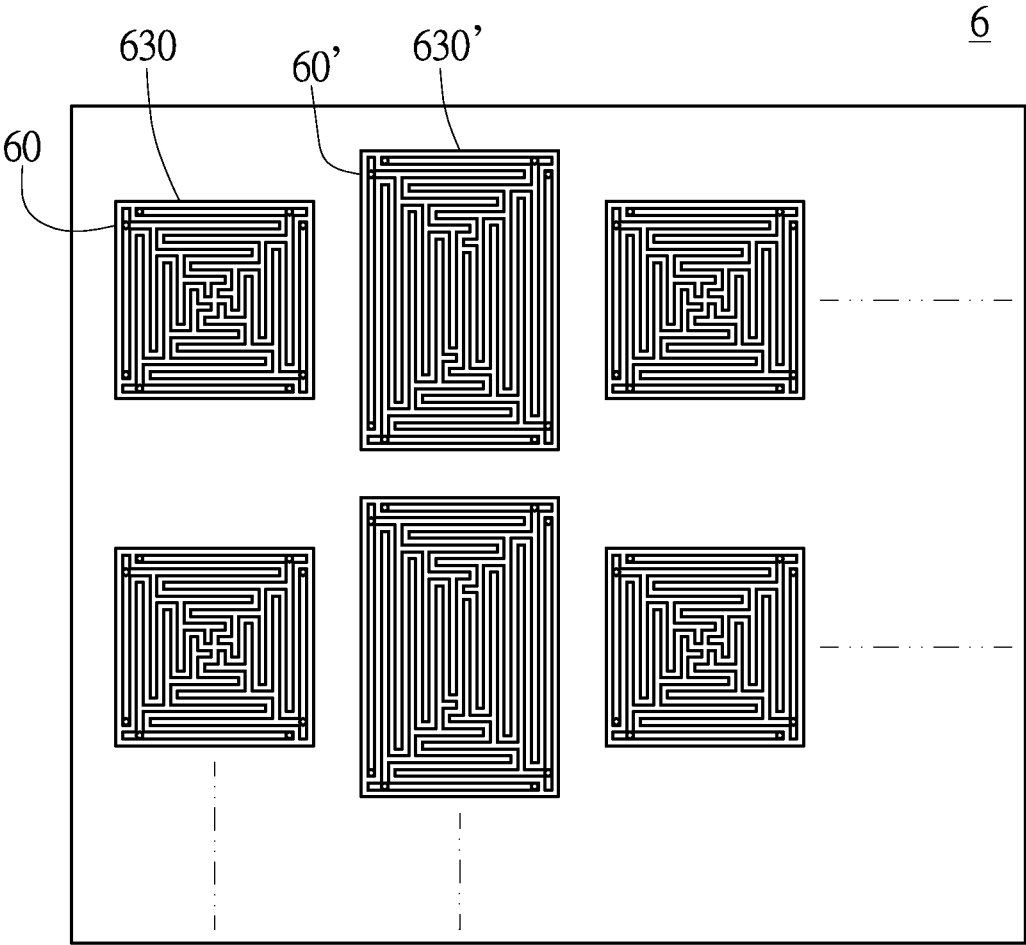

FIG. 11

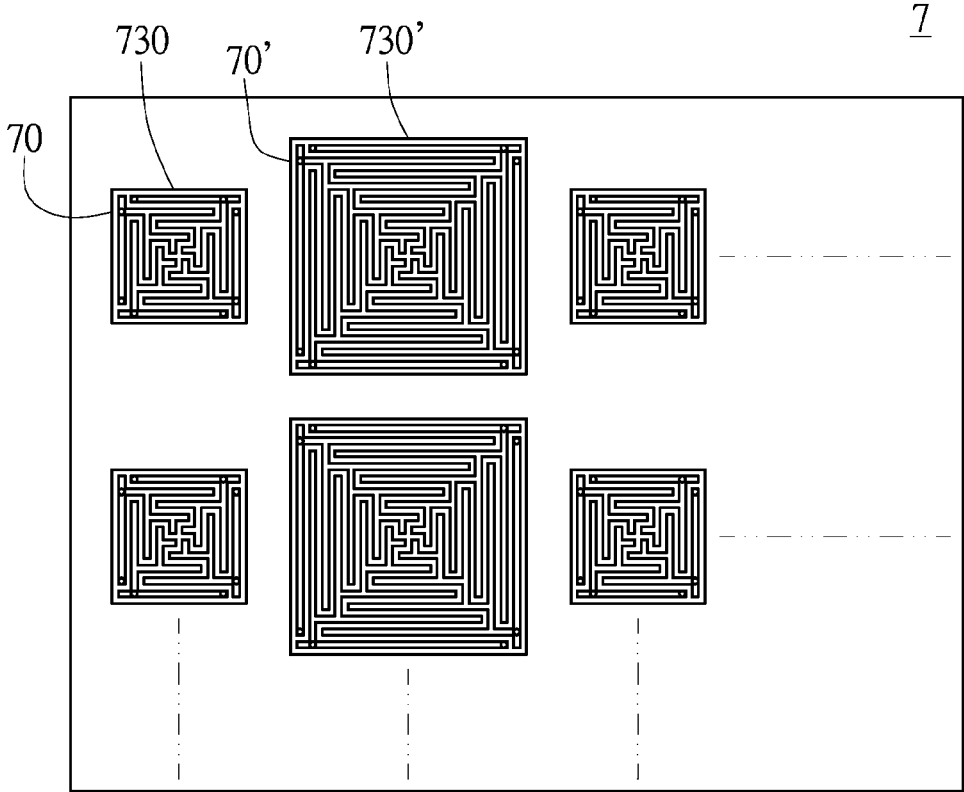

FIG.12

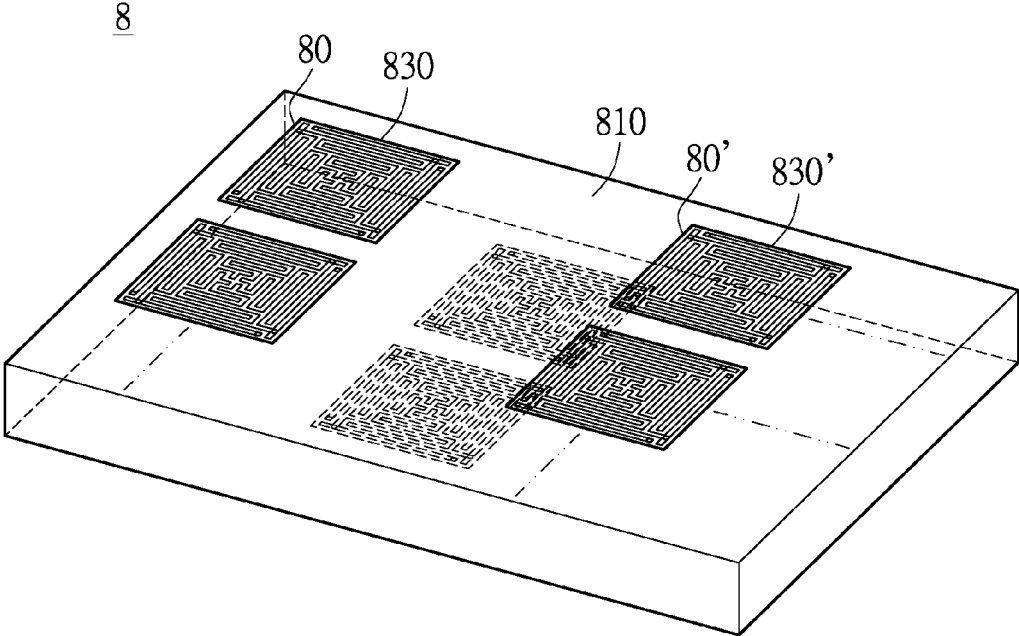

FIG.13

FREQUENCY REFLECTING UNIT

BACKGROUND

1. Technical Field

The present invention generally relates to a frequency reflecting unit, more particularly, to a frequency reflecting unit having a three dimensional structure.

2. Description of Related Art

A frequency reflector is generally used on an elliptical dish antenna reflector, and may be designed to have band-stop frequencies covering a wide frequency range. The frequency reflector is applicable to radars on the ground or missiles in the air to shield the antennas installed on the radars or the missiles from most of the electromagnetic waves to protect the antennas from being interfered with by environmental noise.

Conventionally, the frequency reflector is implemented by a metal radome, which is applicable to airplanes, missiles, and navigation. However, since the metal radome is too large in size, the frequency reflector based on the metal radome is not suitable for use in portable electronic apparatuses. Therefore, a frequency reflector including the metal pattern and a dielectric substrate has been provided. On the positive side or the back side of at least one layer in the dielectric substrate are disposed periodically arranged metal patterns, for example, a cross-shaped or U-shaped metal pattern.

The frequency characteristics of the frequency reflector depend on the interactions between the periodically arranged metal patterns and electromagnetic waves. Thus, the frequency reflector exhibits excellent selectivity with respect to the electromagnetic waves within the band-pass frequencies, while reflecting the electromagnetic waves within the band-stop frequencies. Since band-pass filters can selectively filter out undesired noise, band-pass filters are widely used in electromagnetic interference (EMI) protection.

In the prior art, to lower the band-pass frequencies and the band-stop frequencies for the frequency reflector, a capacitor or an inductor is required to be attached onto the two-dimensional surface of the frequency reflector. In other words, the attachment of a capacitor or an inductor to lower the band-pass frequencies leads to an increased area of the frequency reflector that limits the applications of the frequency reflector. Therefore, there is a need to provide a frequency reflector without increasing the area, while lowering the band-pass frequencies and the band-stop frequencies for the frequency reflector.

SUMMARY

One embodiment of the present invention provides a frequency reflecting unit with a three-dimensional structure. The spatial filter unit is used as a portion of a frequency reflector. The frequency reflecting unit includes a metal pattern and at least one via. The metal pattern is disposed on a metal layout layer defined on one side of the frequency reflecting unit. One end of the via is disposed corresponding to the metal pattern. The via forms a non-zero angle with the metal layout layer. The other end of the via corresponding to the metal pattern is an open circuit.

One embodiment of the present invention provides a frequency reflecting unit with a three-dimensional structure used as a portion of a frequency reflector. The frequency reflecting unit includes a metal pattern, a metal back plate and at least one via. The metal pattern is disposed on a metal layout layer defined on one side of the frequency reflecting

unit. The metal back plate is disposed on the other side of the frequency reflecting unit opposite to the metal layout layer. One end of the via is disposed corresponding to the metal pattern. The via forms a non-zero angle with the metal layout layer. The other end of the via corresponding to the metal pattern is an open circuit.

One embodiment of the present invention provides a frequency reflecting unit with a three-dimensional structure used as a portion of a frequency reflector. The frequency reflecting unit includes a three-dimensional metal pattern. The three-dimensional metal pattern is disposed on a metal layout layer defined on one side of the frequency reflecting unit. A portion of at least one metal conductor extends outwards to a periphery of the metal layout layer and is an open circuit. The at least one metal conductor forms a non-zero angle with the metal layout layer.

As stated above, one embodiment of the present invention provides a frequency reflecting unit. In the frequency reflecting unit, the via forms a non-zero angle with the corresponding metal layout layer so that the frequency reflecting unit has a three-dimensional structure. A plurality of frequency reflecting units are periodically arranged to form a frequency reflector. Since an equivalent capacitor and an equivalent inductor are induced between the vias of neighboring frequency reflecting units, no additional capacitors and inductors are required on the two-dimensional surface of the frequency reflector to lower the band-pass frequencies and the band-stop frequencies for the frequency reflector. Compared to the currently available frequency reflectors, the frequency reflector in one embodiment of the present invention exhibits lowered the communication frequencies for the frequency reflector without needing a large area.

Furthermore, in the frequency reflecting unit with a three-dimensional metal pattern, a portion of at least one metal conductor of the three-dimensional metal pattern extends outwards to the metal layout layer and the metal conductor forms a non-zero angle with the metal layout layer. Similarly, an equivalent capacitor and an equivalent inductor are induced between the three-dimensional metal patterns of neighboring frequency reflecting units, no additional capacitors and inductors are required on the two-dimensional surface of the frequency reflector to lower the band-pass frequencies and the band-stop frequencies for the frequency reflector.

Furthermore, the metal pattern of the frequency reflector exhibits different reflection and transmission characteristics with respect to different angles and different frequencies of incident electromagnetic waves. When electromagnetic waves with different incident angles are within the band-pass frequencies for the metal pattern, total transmission occurs for the selected frequency range. On the contrary, when electromagnetic waves with different incident angles are within the band-stop frequencies for the metal pattern, the incident electromagnetic waves are totally reflected. Thus, the band-pass frequencies of the frequency reflector can be adjusted by designing the metal pattern of the frequency reflector so as to prevent the electronic apparatus circuitry from being interfered with by environmental noise.

In order to further understand the techniques, means and effects of the present disclosure, the following detailed descriptions and appended drawings are hereby referred to, such that, and through which, the purposes, features and aspects of the present disclosure can be thoroughly and concretely appreciated; however, the appended drawings are

merely provided for reference and illustration, without any intention to be used for limiting the present disclosure.

BRIEF DESCRIPTION OF THE DRAWINGS

The accompanying drawings are included to provide a further understanding of the present disclosure, and are incorporated in and constitute a part of this specification. The drawings illustrate exemplary embodiments of the present disclosure and, together with the description, serve to explain the principles of the present disclosure.

FIG. 1A is a cross-sectional view of a frequency reflector according to one embodiment of the present invention;

FIG. 1B is a top view of a frequency reflector according to one embodiment of the present invention;

FIG. 2A is a perspective view of a frequency reflecting unit according to one embodiment of the present invention;

FIG. 2B is a top view of a frequency reflecting unit according to one embodiment of the present invention;

FIG. 2C is a cross-sectional view of a frequency reflecting unit according to one embodiment of the present invention;

FIG. 3 is a schematic diagram showing a capacitor formed between two frequency reflecting units according to one embodiment of the present invention;

FIG. 4A is a graph showing transmittance curves for the transverse electric wave and the transverse magnetic wave with different angles received by the frequency reflector as shown in FIG. 1A and FIG. 1B;

FIG. 4B is a graph showing transmittance curves for the transverse electric wave and the transverse magnetic wave with different angles received by a conventional frequency reflector;

FIG. 5 is a schematic diagram of a frequency reflector attached onto the housing of an electronic apparatus according to another embodiment of the present invention;

FIG. 6A to FIG. 6C are top views of frequency reflecting units according to other embodiments of the present invention;

FIG. 7A to FIG. 7D are top views of frequency reflecting units according to other embodiments of the present invention;

FIG. 8A to FIG. 8B are perspective views of frequency reflecting units according to another embodiment of the present invention;

FIG. 9 is a perspective view of a frequency reflecting unit according to another embodiment of the present invention;

FIG. 10A is a perspective view of a frequency reflecting unit according to another embodiment of the present invention;

FIG. 10B is a top view of a frequency reflecting unit according to another embodiment of the present invention;

FIG. 10C is a cross-sectional view of a frequency reflecting unit according to another embodiment of the present invention;

FIG. 11 is a top view of a frequency reflector according to another embodiment of the present invention;

FIG. 12 is a top view of a frequency reflector according to another embodiment of the present invention; and

FIG. 13 is a perspective view of a frequency reflector according to another embodiment of the present invention.

DESCRIPTION OF THE EXEMPLARY EMBODIMENTS

The detailed description set forth below in connection with the appended drawings is intended as a description of certain embodiments of the present disclosure, and is not

intended to represent the only forms that may be developed or utilized. The description sets forth the various functions in connection with the illustrated embodiments, but it is to be understood that the same or equivalent functions may be accomplished by different embodiments that are also intended to be encompassed within the scope of the present disclosure.

While such terms as “first,” “second,” etc., may be used to describe various components, such components must not be limited to the above terms. The above terms are used only to distinguish one component from another. For example, a second component may be referred to as a first component within the scope of the present invention, and similarly, the first component may be referred to as the second component. As used herein, the term “and/or” includes any and all combinations of one or more of the associated listed items.

(Embodiment of Frequency Reflector)

Please refer to FIG. 1A and FIG. 1B. FIG. 1A is a cross-sectional view of a frequency reflector according to one embodiment of the present invention; and FIG. 1B is a top view of a frequency reflector according to one embodiment of the present invention. As shown in FIG. 1A and FIG. 1B, the frequency reflector 1 is suitable for using in preventing the antennas from being interfered with by the environment. The frequency reflector 1 includes a plurality of frequency reflecting units 10, 10' periodically arranged. The frequency reflector 1 includes a dielectric layer 110, a metal layout layer 120 and a plurality of vias 170 disposed in the dielectric layer 110.

The frequency reflecting unit 10 is, for example, a spatial filter unit or a wave absorbing unit. When the frequency reflecting unit 10 is a spatial filter unit, the frequency reflecting unit 10 only allows the transverse electric waves or the transverse magnetic waves within a specific frequency range to penetrate, and reflects the transverse electric waves or the transverse magnetic waves within other frequency ranges. When the frequency reflecting unit 10 is a wave absorbing unit, the frequency reflecting unit 10 absorbs the transverse electric waves or the transverse magnetic waves within a specific frequency range, and reflects the transverse electric waves or the transverse magnetic waves within other frequency ranges. One embodiment of the present invention is exemplified by, but not limited to, the frequency reflecting unit 10 implemented using a spatial filter unit.

With reference to FIG. 1A and FIG. 1B, a metal layer is formed on the dielectric layer 110 in advance. A plurality of periodically arranged metal patterns 130, 130' are formed on the metal layer by photolithography or laser cutting so as to define a metal layout layer 120. In other words, a plurality of metal patterns 130, 130' are disposed on the defined metal layout layer 120. Each of the metal patterns 130, 130' corresponds to a frequency reflecting unit 10, 10'. Each of the metal patterns 130, 130' may be formed by a plurality of metal conductors 150, 150' connected at a symmetric center 132, 132' of the metal patterns 130, 130'. On the other hand, another side of the dielectric layer 110 opposite to the metal layout layer 120 is not provided with any metal layer.

Each of metal conductors 150, 150' extends inwards from a periphery 131, 131' of the metal pattern 130, 130'. A long side 151, 151' of the metal conductor 150, 150' is disposed on the periphery 131, 131' corresponding thereto. The long side 151 of the metal conductor 150 of the metal pattern 130 is adjacent to the long side 151' of the metal conductor 150' of another metal pattern 130' adjacent to the metal pattern 130.

It should be noted that, in the present embodiment, each of the metal patterns 130, 130' is formed by the plurality of

5

metal conductors **150**, **150'** connected at the symmetric center **132**, **132'** of the metal patterns **130**, **130'**. However, in other embodiments, the plurality of metal conductors **150**, **150'** may be isolated from each other without any connection, or may be connected elsewhere on the metal patterns **130**, **130'**.

Please refer to FIG. 1A and FIG. 1B, in view of FIG. 2A to FIG. 2C. FIG. 2A is a perspective view of a frequency reflecting unit according to one embodiment of the present invention; FIG. 2B is a top view of a frequency reflecting unit according to one embodiment of the present invention; and FIG. 2C is a cross-sectional view of a frequency reflecting unit according to one embodiment of the present invention. In addition to the metal pattern **130**, the frequency reflecting unit **10** further includes at least one via **170** disposed in the dielectric layer **110**. One end of the via **170** is disposed corresponding to the metal pattern **130**, and the via **170** forms a non-zero angle with the metal layout layer **120**.

In the present embodiment, the via **170** is further electrically connected to the long side **151** of one of the metal conductors **150** and forms a non-zero angle with the metal layout layer **120** so that the frequency reflecting unit **10** extends towards a direction other than the metal pattern **130**. The other end of the via **170** corresponding to the metal pattern **130** on the metal layout layer **120** is an open circuit. For example, if the metal pattern **130** extends inwards from the periphery **131**, **131'** along the x-y plane, one end of the via **170** is disposed corresponding to the metal pattern **130** along the z-axis. The via **170** forms a non-zero angle with the metal layout layer **120**. For example, the via **170** forms a 90-degree angle with the metal layout layer **120** so that the frequency reflecting unit **10** is cubic.

It should be noted that, the present invention is not limited to the number of vias **170**. In one embodiment of the present invention, the number of vias **170** is two on each of the four sides. The vias **170** are electrically connected to both ends of the long side **151** of one of the metal conductors **150**. In other embodiments, the number of vias **170** may be five or another different number on each of the four sides.

On the other hand, the present invention is not limited to how the via **170** is disposed. In one embodiment of the present invention, the via **170** is disposed corresponding to the periphery **131** of the metal pattern **130**. In other embodiments, the via **170** may also be disposed elsewhere corresponding to the metal pattern **130**.

It should be noted that, in one embodiment of the present invention, the via **170** is electrically connected to the long side **151** of one of the metal conductors **150**. However, the present invention is not limited thereto. The via **170** may also be isolated from any metal conductor **150** on the metal pattern **130**, or any metal conductor **150** on the metal pattern **130** may be electrically connected between the two ends of the via **170**. In other words, the present invention is not limited to how the via **170** is connected.

However, it is preferable that, to efficiently enhance the capacitance of the capacitor between the frequency reflecting units **10**, **10'**, the via **170** is disposed corresponding to the periphery **131** of the metal pattern **130**. Simply put, the present invention is not limited to the number of vias **170** of the frequency reflecting unit **10** and how the vias **170** are disposed. Those with ordinary skill in the art may make modifications to the structure of the frequency reflecting unit **10** according to practical demands.

Furthermore, the frequency reflecting unit **10** and another frequency reflecting unit **10'** adjacent to the frequency reflecting unit **10** may include different numbers of vias **170**,

6

170'. In the present embodiment, the frequency reflecting unit **10** and the frequency reflecting unit **10'** include two vias **170**, **170'** disposed on each of the four sides. In other embodiments, the frequency reflecting unit **10** may include two vias **170** disposed on each side, while the frequency reflecting unit **10'** may include three vias **170'** disposed on each side. However, the present invention is not limited to the same number of vias **170**, **170'** disposed in each frequency reflecting unit **10**, **10'**. To make it more clear, in one embodiment of the present invention, two vias **170** are disposed on each side of the frequency reflecting unit **10**.

Please refer to FIG. 3. FIG. 3 is a schematic diagram showing a capacitor formed between two frequency reflecting units according to one embodiment of the present invention. Since the via **170** of the frequency reflecting unit **10** is adjacent to the via **170'** of another frequency reflecting unit **10'** adjacent to the frequency reflecting unit **10**, an equivalent capacitor with a large capacitance is formed between the via **170** and the via **170'**. Furthermore, the metal conductor **150** or **150'** extends inwards from the periphery **131**, **131'** to form an equivalent inductor with a larger inductance. Accordingly, no additional capacitors and/or inductors are required to be attached onto the frequency reflecting unit **10** to lower the band-pass frequencies and the band-stop frequencies. Compared to the conventional frequency reflector, the area of the frequency reflecting unit **10** in one embodiment of the present invention is reduced so that the frequency reflector **1** may be further minimized.

Furthermore, a plurality of periodically arranged metal patterns **130**, **130'** form a large-area metal surface. Thus, the frequency reflector **1** only allows the electromagnetic waves within the band-pass frequencies on metal pattern **130**, **130'** to penetrate, and reflects the electromagnetic waves within the band-stop frequencies. The band-pass frequencies and the band-stop frequencies for the frequency reflector **10**, **10'** depend on any of the total length of the metal conductor **150**, **150'**, the number of vias **170**, **170'**, the total length of the vias **170**, **170'**, and how the vias **170**, **170'** are disposed. Hence, the band-pass frequencies of the frequency reflector can be adjusted by designing the total length of the metal conductor **150**, **150'**, the number of vias **170**, **170'**, the total length of the vias **170**, **170'**, and how the vias **170**, **170'** are disposed so as to prevent the electronic apparatus circuitry from being interfered with by environmental noise.

In the present embodiment, the metal patterns **130**, **130'** are two-dimensional metal patterns being a square with the same size and shape. Each of the metal patterns **130**, **130'** includes four metal conductors **150**, **150'**. The metal conductor **150**, **150'** extend inwards from the periphery **131**, **131'** to the symmetric center **132**, **132'** on the metal pattern **130**, **130'**. However, the present invention is not limited thereto. The metal pattern **130**, **130'** may be a polygon or a curve. The shape or the size of the metal pattern **130**, **130'** may be different. The metal patterns **130**, **130'** may also be three-dimensional metal patterns. However, it is preferable that the metal pattern **130**, **130'** is a symmetric curve or a symmetric polygon. The metal conductor **150**, **150'** extends inwards from the periphery **131**, **131'** to the symmetric center **132**, **132'** on the metal pattern **130**, **130'** to reduce the influence of the incident angle on the frequency reflector.

It should be noted that the present invention is not limited to the number of metal patterns **130**, **130'** that form the metal layout layer **120** of the frequency reflector **1**. Those with ordinary skill in the art may modify the number of metal patterns **130**, **130'** according to practical demands. On the other hand, the present invention is not limited to the materials of the dielectric layer **110**. Those with ordinary

skills in the art may modify the materials of the dielectric layer **110** to work with the metal layout layer **120** according to practical demands.

In the embodiment shown in FIG. **1A** and FIG. **1B**, the dielectric layer **110** is a single-layered dielectric layer, and the metal patterns **130**, **130'** of the frequency reflecting units **10**, **10'** are disposed on the top surface of the dielectric layer **110**. However, the present invention is not limited thereto. For example, the metal patterns **130**, **130'** are disposed on a bottom surface of the dielectric layer **110** (meanwhile, the bottom surface of the dielectric layer **110** is provided with another metal layout layer not shown in FIG. **1A** and **1B**). Alternatively, the metal patterns **130**, **130'** are disposed alternately on the bottom surface and the top surface of the dielectric layer **110** (meanwhile, both of the bottom surface and the top surface of the dielectric layer **110** are provided with metal layout layers). The vias **170**, **170'** are disposed corresponding to the metal patterns **130**, **130'**. In addition, the dielectric layer **110** may be a multi-layered dielectric layer. The metal patterns **130**, **130'** are disposed on the same or different top surface and/or the bottom surface.

In the present embodiment, the metal conductors **150**, **150'** are serpentine metal conductors that extend inwards to a symmetric center **132**, **132'** and are connected at the symmetric center **132**, **132'**. However, the present invention is not limited to the shape of the metal conductors **150**, **150'**. In other embodiments, in addition to extending from the periphery **131**, **131'** towards the symmetric center **132**, **132'**, some dendritic portions of the metal conductors **150**, **150'** do not extend to the symmetric center **132**, **132'**. Generally speaking, the metal conductors **150**, **150'** extend from the periphery **131**, **131'** to the symmetric center **132**, **132'**.

Please refer to FIG. **4A** and FIG. **4B**. FIG. **4A** is a graph showing transmittance curves for the transverse electric wave and the transverse magnetic wave with different angles received by the frequency reflector as shown in FIG. **1A** and FIG. **1B**; and FIG. **4B** is a graph showing transmittance curves for the transverse electric wave and the transverse magnetic wave with different angles received by a conventional frequency reflector. It should be noted that the frequency reflector **1** is only different from the conventional frequency reflector in that the frequency reflecting unit **10** of the frequency reflector **1** further includes at least one via **170**, while the conventional frequency reflector does not include any via **170**.

In FIG. **4A**, the longitudinal axis denotes the transmittance in dB, and the transverse axis denotes the frequency in giga-Hertz (GHz). The curves **S100** and **S200** represent the transmittance as a function of frequency of the frequency reflector **1** with respect to the transverse electric waves with an incident angle of 0 and 75 degrees. The curve **S300** represents the transmittance as a function of frequency of the frequency reflector **1** with respect to the transverse magnetic waves with an incident angle of 75 degrees. In FIG. **4B**, the longitudinal axis and the transverse axis are similar to those in FIG. **4A**, and thus descriptions thereof are not redundantly repeated herein. In FIG. **4B**, the curves **S100'** and **S200'** represent the transmittance as a function of frequency of the conventional frequency reflector with respect to the transverse electric waves with an incident angle of 75 degrees. The curve **S300'** represents the transmittance as a function of frequency of the conventional frequency reflector with respect to the transverse magnetic waves with an incident angle of 75 degrees.

In view of FIG. **4A** and FIG. **4B**, under the circumstance that the frequency reflector **1** and the conventional frequency reflector include the same number of frequency reflecting

units **10** and the metal patterns **130** have the same shape, the band-stop frequencies for the conventional frequency reflector centers at 7.96 GHz, while the band-stop frequencies for the frequency reflector **1** drops to about 2.36 GHz. In other words, if the user desires to filter out the noise centering at 2.36 GHz, the frequency reflector **1** in one embodiment of the present invention may achieve the same performance with a reduced area.

As stated above, one embodiment of the present invention employs a via **170** to effectively enhance the equivalent capacitor and the equivalent inductor of the frequency reflecting unit **10** to further adjust the band-pass frequencies and band-stop frequencies of the frequency reflector **1**. Compared to the currently available frequency reflectors, the frequency reflector **1** in one embodiment of the present invention can further be minimized.

(Embodiment of Electronic Apparatus)

Please refer to FIG. **5**, which is a schematic diagram of a frequency reflector attached onto the housing of an electronic apparatus according to another embodiment of the present invention. The frequency reflector **1** can be applicable to the electronic apparatus **2**, to which the present invention is not limited. The electronic apparatus **2** typically includes a housing **21** and an electronic apparatus circuitry **22**. The housing **21** covers the electronic apparatus circuitry **22**. By disposing or attaching the frequency reflector **1** onto the housing **21**, the electronic apparatus **2** may be prevented from being interfered with by the environment. Furthermore, the electronic apparatus **2** may be, for example, a cell phone, a personal tablet PC, a notebook computer or an electronic radar.

Taking the communication frequencies used in the third generation mobile communication for example, the band-pass frequencies for the frequency reflector **1** may be designed to center at 900 MHz, 1800 MHz or 2000 MHz. Accordingly, if the frequency reflector **1** is disposed on the housing of a cell phone, the antenna in the cell phone is not influenced by the frequency reflector **1** and is able to receive and transmit signals. However, the electromagnetic waves away from the band-pass frequencies are reflected by the frequency reflector **1**. Thus, the frequency reflector **1** may protect the cell phone from being interfered with by the environmental noise. Furthermore, the directivity and the gain along a specific direction of the antenna in the electronic apparatus **2** may be improved by the characteristics of the frequency reflector **1**.

(Other Embodiments of Frequency Reflecting Unit)

With reference to FIG. **6A**, FIG. **6A** is a top view of a frequency reflecting unit according to another embodiment of the present invention. Compared to the metal conductor **150**, **150'** on the metal pattern **130**, **130'** in FIG. **1B**, the metal conductor **150A** on the metal pattern **130A** in FIG. **6A** is also a serpentine metal conductor, but the metal conductor **150A** does not include a dendritic portion that does not extend towards the symmetric center **132**, **132'**. The metal pattern **130A** in FIG. **6A** may replace the metal pattern **130**, **130'** in FIG. **1B** to form another type of frequency reflector.

With reference to FIG. **6B**, FIG. **6B** is a top view of a frequency reflecting unit according to another embodiment of the present invention. Compared to the metal conductor **150**, **150'** on the metal pattern **130**, **130'** in FIG. **1B**, the metal conductor **150B** on the metal pattern **130B** in FIG. **6B** is a dendritic metal conductor with a long side **151B** disposed on the periphery **131B**. The long side **151B** is a branch portion of the main trunk portion of the metal conductor **150B**. In FIG. **6B**, the metal conductor **150B** includes other branch portions with length smaller than the long side **151B**. The

metal pattern **130B** in FIG. **6B** may replace the metal pattern **130**, **130'** in FIG. **1B** to form another type of frequency reflector.

With reference to FIG. **6C**, FIG. **6C** is a top view of a frequency reflecting unit according to another embodiment of the present invention. The metal conductor **150C** on the metal pattern **130C** in FIG. **6C** is similar to the metal conductor **150**, **150'** on the metal pattern **130**, **130'** in FIG. **1B**. However, the metal pattern **130C** in FIG. **6C** only has two metal conductors **150C**. In other words, the metal pattern **130C** in FIG. **6C** is not a square, but a symmetric dual taper including two triangles. The metal pattern **130C** in FIG. **6C** may replace the metal pattern **130**, **130'** in FIG. **1B** to form another type of frequency reflector.

Please refer to FIG. **7A** to FIG. **7D**. FIG. **7A** to FIG. **7D** are top views of frequency reflecting units according to other embodiments of the present invention. In FIG. **7A** to FIG. **7D**, the metal patterns of the frequency reflecting units are respectively a triangle, a hexagon, a circle and a symmetric curve. The metal pattern in FIG. **7A** includes three serpentine metal conductors. The metal pattern in FIG. **7B** includes six serpentine metal conductors. The metal pattern in FIG. **7C** includes three serpentine metal conductors. The metal pattern in FIG. **7D** includes four serpentine metal conductors. The metal patterns in FIG. **7A** to FIG. **7D** may replace the metal pattern **130**, **130'** in FIG. **1B** to form another type of frequency reflector.

Please refer to FIG. **8A**. FIG. **8A** is a perspective view of a frequency reflecting unit according to another embodiment of the present invention. The frequency reflecting unit **20** in FIG. **8A** is different from the frequency reflecting unit **10** in FIG. **2** in that the metal pattern **230** of the frequency reflecting unit **20** in FIG. **8A** includes four fork-shaped metal conductors **250**. The periphery of each of the fork-shaped metal conductors **250** includes three vias **270**. The vias **270** are not electrically connected to one another. It should be noted that the vias **270** are not electrically connected to the fork-shaped metal conductor **250**. The frequency reflecting unit **20** in FIG. **8A** may replace the frequency reflecting unit **10** in FIG. **2** to form other types of frequency reflectors.

With reference to FIG. **8B**, FIG. **8B** is a perspective view of a frequency reflecting unit according to another embodiment of the present invention. The frequency reflecting unit **30** in FIG. **8B** is different from the frequency reflecting unit **10** in FIG. **2** in that the long side **351** of each of the metal conductors **350** of the frequency reflecting unit **30** in FIG. **8B** is only electrically connected to a via **370A**. The via **370A** is electrically connected to another via **370B** through a conductor element **371** that is **h1** cm below the long side **351** of the metal conductor **350**, and **h1** is greater than zero. Then, the via **370B** is further electrically connected to the via **370C** through another conductor element **371'** that is **h2** cm below the conductor element **371**, and **h2** is greater than zero. Accordingly, the capacitance of the equivalent capacitor formed between the frequency reflecting unit **30** and another frequency reflecting unit **30'** adjacent to the frequency reflecting unit **30** may be further enhanced.

It should be noted that the conductor elements **371**, **371'** may be designed to be serpentine or straight. Those with ordinary skill in the art may make modification on the length or the width of the conductor elements **371**, **371'** so that the impedance of the frequency reflecting unit **30** increases. The conductor elements **371**, **371'** connecting different vias **370A**, **370B** and **370C** may include any conductive material. The present invention is not limited to the conductive material to electrically connect different vias. The present invention is not limited to the number of the conductor

elements **371**, **371'**. In the present embodiment, the via **370A** is electrically connected to the via **370B** through the conductor element **371**, the via **370B** is electrically connected to the via **370C** through the conductor element **371'**. In other embodiments, the via **370C** may also be electrically connected to other vias through a conductor element (not shown in FIG. **8B**). Furthermore, the present invention is not limited to **h1** and **h2**. Those with ordinary skill in the art may modify **h1** and **h2** according to practical demands. As stated above, those with ordinary skill in the art can modify the structure of the frequency reflecting unit **30** to adjust the band-pass frequencies and the band-stop frequencies for the frequency reflector.

Please refer to FIG. **9**. FIG. **9** is a perspective view of a frequency reflecting unit according to another embodiment of the present invention. Unlike the previous embodiments, the frequency reflecting unit **40** in FIG. **9** does not employ a plurality of vias to increase the capacitance of the equivalent capacitor and the inductance of the equivalent inductor of the frequency reflecting unit **40**. Instead, the metal pattern **430** of the frequency reflecting unit **40** is a three-dimensional metal pattern. Certainly, at least one via can be disposed in the frequency reflecting unit **40**.

In one embodiment of the present invention, the metal pattern **430** is a square including four metal conductors **450**. In addition to extending from the periphery towards the symmetric center on the metal pattern **430**, the metal conductor **450** further extends downwards. The metal conductor **450** forms a non-zero angle with the metal layout layer so that the metal pattern **430** is a three-dimensional metal pattern. The portion of the metal conductor **450** extending downwards is an open circuit. An equivalent capacitor with a larger capacitance may be formed between the frequency reflecting unit **40** and another frequency reflecting unit (not shown) through the portion of the metal conductor **450** extending downwards. Simply put, the portion of the metal conductor **450** extending downwards may replace the plurality of vias in the previous embodiment to increase the capacitance of the equivalent capacitor of the frequency reflecting unit **40**.

Please refer to FIG. **10A** to FIG. **10C**. FIG. **10A** is a perspective view of a frequency reflecting unit according to another embodiment of the present invention; FIG. **10B** is a top view of a frequency reflecting unit according to another embodiment of the present invention; and FIG. **10C** is a cross-sectional view of a frequency reflecting unit according to another embodiment of the present invention. Similarly, the frequency reflecting unit **50** includes a dielectric layer **510**, a metal layout layer **520** and at least one via **570**. Unlike FIG. **2A** to FIG. **2C**, the frequency reflecting unit **50** of the present embodiment is a wave absorbing unit. The frequency reflecting unit **50** further includes at least one resistor **540** to cause loss in the transverse electric wave or the transverse magnetic wave. The resistor **540** is disposed on the long side **551** of the metal conductor **550**. In the present embodiment, a resistor **540** is disposed on the long side **551** of each of the metal conductors **550**, to which the present invention is not limited. Furthermore, a metal back plate **580** is disposed on the other side of the frequency reflecting unit **50** corresponding to metal layout layer **520**. The metal back plate **580** is not disposed any metal pattern thereon. In one embodiment of the present invention, both ends of the via **570** correspond to the metal layout layer **520** and the metal back plate **580**. One end of the via **570** corresponding to the metal back plate **580** is an open circuit. However, the present invention is not limited thereto. In other embodiments, the via **570** is electrically connected to the metal layout layer **520** and the metal

11

back plate **580** respectively, is only electrically connected to the metal back plate **580**, or is only electrically connected to the metal layout layer **520**.

With a metal conductor **550** and a resistor **540** disposed on the metal layout layer **520** and a metal back plate **580** corresponding to the metal layout layer **520**, the frequency reflecting unit **50** can absorb the transverse electric wave or the transverse magnetic wave within a specific frequency range and reflect the transverse electric wave or the transverse magnetic wave away from the specific frequency range.

It should be noted that, in other embodiments, the metal layout layer **520** may not provide a resistor **540** disposed thereon. Instead, the metal conductor **550** and the via **570** may include low conductivity materials such as graphite, karkogel and elargol. Accordingly, the metal conductor **550** and the via **570** may cause loss in the transverse electric wave or the transverse magnetic wave.

Please refer to FIG. **11**. FIG. **11** is a top view of a frequency reflector according to another embodiment of the present invention. Compared to the frequency reflector **1** in FIG. **1B**, the frequency reflector **6** in FIG. **11** includes a plurality of frequency reflecting units **60**, **60'** with different sizes and shapes. The metal patterns **630**, **630'** of the frequency reflecting units **60**, **60'** are a square and a rectangle. The metal patterns **630**, **630'** include four metal conductors, and the metal conductors may be serpentine metal conductors.

Please refer to FIG. **12**. FIG. **12** is a top view of a frequency reflector according to another embodiment of the present invention. Compared to the frequency reflector **1** in FIG. **1B**, the frequency reflector **7** in FIG. **12** includes a plurality of frequency reflecting units **70**, **70'** with different sizes and the same shape being a square. The metal patterns **730**, **730'** of the frequency reflecting units **70**, **70'** include four metal conductors, and the metal conductors may be serpentine metal conductors.

Then, with reference to FIG. **13**, FIG. **13** is a perspective view of a frequency reflector according to another embodiment of the present invention. Compared to the frequency reflector **1** in FIG. **1B**, the frequency reflector **8** in FIG. **13** includes a plurality of frequency reflecting units **80**, **80'** disposed respectively on the top surface and the bottom surface of the dielectric layer **810**. The metal patterns **830**, **830'** of the frequency reflecting units **80**, **80'** include four metal conductors, and the metal conductors may be serpentine metal conductors.

(Function of the Embodiment)

As stated above, one embodiment of the present invention provides a frequency reflecting unit. In the frequency reflecting unit, the via forms a non-zero angle with the corresponding metal layout layer so that the frequency reflecting unit has a three-dimensional structure. A plurality of frequency reflecting units are periodically arranged to form a frequency reflector. Since an equivalent capacitor and an equivalent inductor are induced between the vias of neighboring frequency reflecting units, no additional capacitors and inductors are required on the two-dimensional surface of the frequency reflector to lower the band-pass frequencies and the band-stop frequencies for the frequency reflector. Compared to the currently available frequency reflectors, the frequency reflector in one embodiment of the present invention exhibits lowered the communication frequencies for the frequency reflector without needing a large area.

Furthermore, in the frequency reflecting unit with a three-dimensional metal pattern, a portion of at least one metal conductor of the three-dimensional metal pattern extends

12

outwards to the metal layout layer and the metal conductor forms a non-zero angle with the metal layout layer. Similarly, an equivalent capacitor and an equivalent inductor are induced between the three-dimensional metal patterns of neighboring frequency reflecting units, and no additional capacitors and inductors are required on the two-dimensional surface of the frequency reflector to lower the band-pass frequencies and the band-stop frequencies for the frequency reflector.

Furthermore, the directivity and the gain along a specific direction of the antenna in the electronic apparatus may be improved by the characteristics of the frequency reflector.

Furthermore, in one embodiment of the present invention, the frequency reflector blocks the electromagnetic waves within the band-stop frequencies and allows the electromagnetic waves within the band-pass frequencies to penetrate. Thereby, the directivity and the gain along a specific direction of the antenna may be improved by the characteristics of the frequency reflector. The metal pattern of the frequency reflector exhibits different reflection and transmission characteristics with respect to different angles and different frequencies of incident electromagnetic waves. When electromagnetic waves with different incident angles are within the band-pass frequencies for the metal pattern, total transmission occurs for the selected frequency range. On the contrary, when electromagnetic waves with different incident angles are within the band-stop frequencies for the metal pattern, the incident electromagnetic waves are totally reflected. Hence, the band-pass frequencies of the frequency reflector can be adjusted by designing the metal pattern of the frequency reflector so as to prevent the electronic apparatus circuitry from being interfered with by environmental noise. Furthermore, in one embodiment of the present invention, the metal pattern can be designed on the same plane or on different planes. Thus, the frequency reflector of the present invention can be used in portable products.

As stated above, the frequency reflector of present invention is applicable to various portable electronic products to provide selective frequency shielding. The frequency reflector of the present invention also prevents the user from being irradiated by the hazardous electromagnetic waves. Hence, the frequency reflector of present invention is very useful.

The above-mentioned descriptions represent merely the exemplary embodiment of the present disclosure, without any intention to limit the scope of the present disclosure thereto. Various equivalent changes, alterations or modifications based on the claims of present disclosure are all consequently viewed as being embraced by the scope of the present disclosure.

What is claimed is:

1. A frequency reflecting unit with a three-dimensional structure used as a portion of a frequency reflector, the frequency reflecting unit comprising:

a metal pattern disposed on a metal layout layer defined on one side of said frequency reflecting unit; and at least one via;

wherein one end of the via being disposed corresponding to the metal pattern, the via forms a non-zero angle with the metal layout layer, and the other end of the via is an open circuit;

wherein the metal pattern comprises a plurality of metal conductors, each of the metal conductors extending inwards from a periphery of the metal pattern, a long side of the metal conductor being disposed on the periphery corresponding thereto;

wherein the via is electrically connected to the long side of one of the plurality of metal conductors.

13

2. The frequency reflecting unit of claim 1, wherein the plurality of metal conductors are not connected to one another.

3. The frequency reflecting unit of claim 1, wherein the plurality of metal conductors are connected to one another at a center of the metal pattern.

4. The frequency reflecting unit of claim 1, further comprising:
a dielectric layer carrying the metal pattern and the via.

5. The frequency reflecting unit of claim 1, wherein the via and the plurality of metal conductors are not electrically connected to each other.

6. The frequency reflecting unit of claim 1, wherein the via is electrically connected to the long side of one of the plurality of metal conductors, and the via is electrically connected to another via through a conductor element that is h cm below the long side, wherein h is greater than zero.

7. The frequency reflecting unit of claim 1, wherein the metal pattern is a curve or polygon.

8. The frequency reflecting unit of claim 5, wherein the curve is a symmetric curve and the polygon is a symmetric polygon.

9. The frequency reflecting unit of claim 1, wherein the metal conductor extends towards a symmetric center of the metal pattern from the periphery corresponding thereto.

10. The frequency reflecting unit of claim 1, wherein the metal conductor is a dendritic metal conductor, a serpentine metal conductor or a fork-shaped metal conductor.

11. The frequency reflecting unit of claim 1, wherein said frequency reflecting unit is a spatial filter unit.

12. The frequency reflecting unit of claim 1, wherein the frequency reflector comprises N of the frequency reflecting units periodically arranged, wherein N is an integer larger than one.

13. The frequency reflecting unit of claim 10, wherein when each of the plurality of frequency reflecting units is the frequency reflecting unit of claim 1, the long side of the metal conductor of the metal pattern of the frequency reflecting unit is adjacent to the long side of the metal conductor of the metal pattern of another frequency reflecting unit.

14

14. A frequency reflecting unit with a three-dimensional structure, used as a portion of a frequency reflector, the frequency reflecting unit comprising:

a metal pattern disposed on a metal layout layer defined on one side of the frequency reflecting unit;

a metal back plate, disposed on the other side of the frequency reflecting unit opposite to said metal layout layer; and

at least one via;

wherein one end of said via is disposed corresponding to the metal pattern, the via forms a non-zero angle with the metal layout layer, and the other end of the via corresponding to the metal pattern is an open circuit;

wherein the metal pattern comprises a plurality of metal conductors, each of the metal conductors extending inwards from a periphery of the metal pattern, a long side of the metal conductor being disposed on the periphery corresponding thereto;

wherein the via is electrically connected to the long side of one of the plurality of metal conductors.

15. The frequency reflecting unit of claim 12, wherein the frequency reflecting unit is a wave absorbing unit.

16. A frequency reflecting unit with a three-dimensional structure, used as a portion of a frequency reflector, the frequency reflecting unit comprising:

a three-dimensional metal pattern disposed on a metal layout layer defined on one side of the frequency reflecting unit; the three-dimensional metal pattern comprises a plurality of metal conductors;

wherein a portion of the plurality of metal conductors extends downwards from a periphery of the metal layout layer and is an open circuit, and at least one of the plurality of metal conductors forms a non-zero angle with said metal layout layer;

wherein the metal pattern comprises a plurality of metal conductors, each of the plurality of metal conductors extending inwards from a periphery of the metal pattern, a long side of the metal conductor being disposed on the periphery corresponding thereto.

* * * * *