



US008098855B2

(12) **United States Patent**
Lee et al.

(10) **Patent No.:** **US 8,098,855 B2**
(45) **Date of Patent:** **Jan. 17, 2012**

(54) **FLEXIBLE ELECTRET ACTUATORS AND METHODS OF MANUFACTURING THE SAME**

(52) **U.S. Cl.** **381/191**
(58) **Field of Classification Search** 381/191
See application file for complete search history.

(75) **Inventors:** **Chih-Kung Lee**, Taipei (TW);
Wen-Ching Ko, Kaohsiung (TW);
Jia-Lun Chen, Tainan (TW); **Wen-Hsin Hsiao**, Longtan Township (TW);
Wen-Jong Wu, Taipei (TW)

(56) **References Cited**

U.S. PATENT DOCUMENTS

2009/0060233 A1* 3/2009 Liou et al. 381/191
* cited by examiner

(73) **Assignee:** **National Taiwan University** (TW)

Primary Examiner — Alexander Ghyka

(*) **Notice:** Subject to any disclaimer, the term of this patent is extended or adjusted under 35 U.S.C. 154(b) by 164 days.

Assistant Examiner — Stanetta Isaac

(74) *Attorney, Agent, or Firm* — Lowe Hauptman Ham & Berner, LLP

(21) **Appl. No.:** **12/186,730**

(57) **ABSTRACT**

(22) **Filed:** **Aug. 6, 2008**

A flexible actuator comprises a thin film and at least one first enclosure with at least one first bendable element coupled to the first enclosure. The thin film may comprise a conductive layer and a first electret layer over a first surface of the conductive layer. The thin film is configured to be bendable. The first enclosure have a first electrode layer as part of the first enclosure. The first enclosure is provided over the first electret layer with the first electrode layer being spaced apart from the first electret layer. The first electrode layer is coupled with a first terminal of an audio signal input. The thin film is configured to interact with the first enclosure in response to audio signals supplied by the audio signal input and to generate sound waves.

(65) **Prior Publication Data**

US 2010/0215197 A1 Aug. 26, 2010

Related U.S. Application Data

(60) Provisional application No. 61/035,300, filed on Mar. 10, 2008.

(30) **Foreign Application Priority Data**

Jan. 4, 2008 (TW) 97100279 A

(51) **Int. Cl.**

H04R 25/00 (2006.01)

27 Claims, 5 Drawing Sheets

500

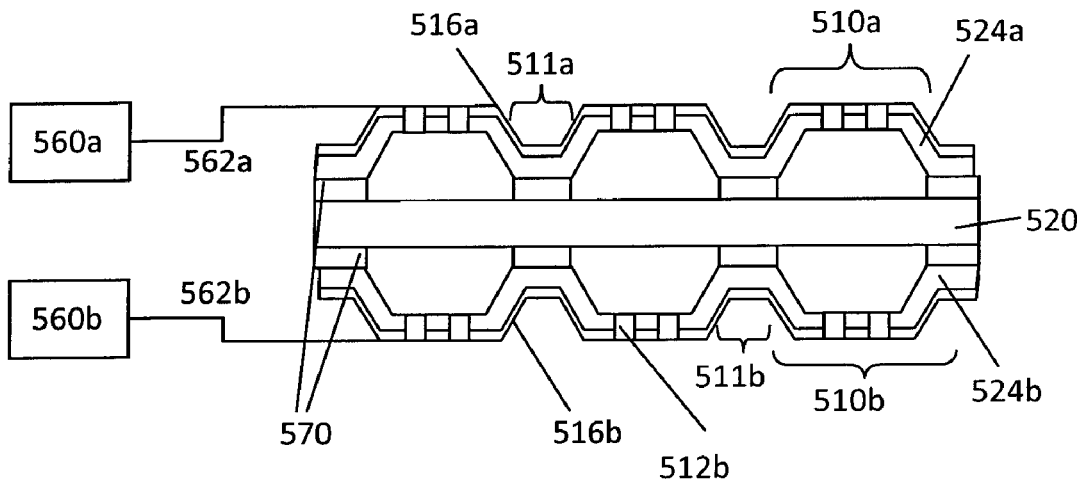

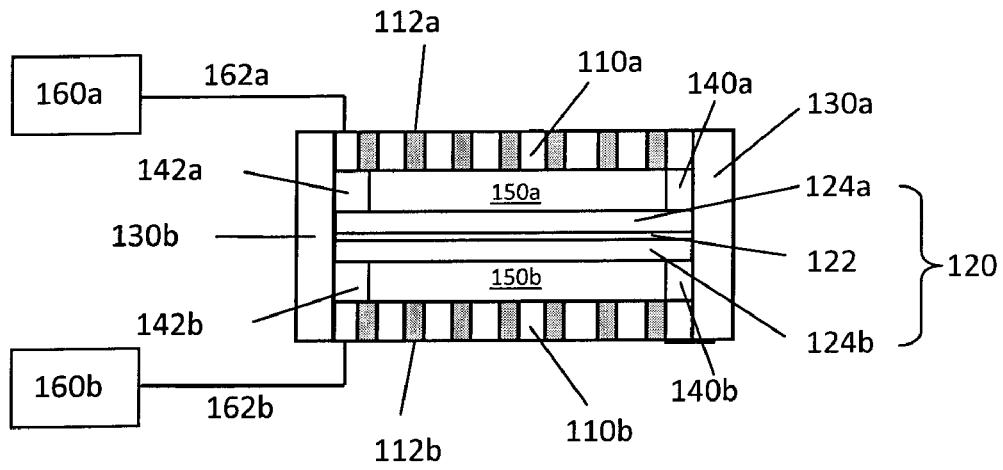

Fig. 1

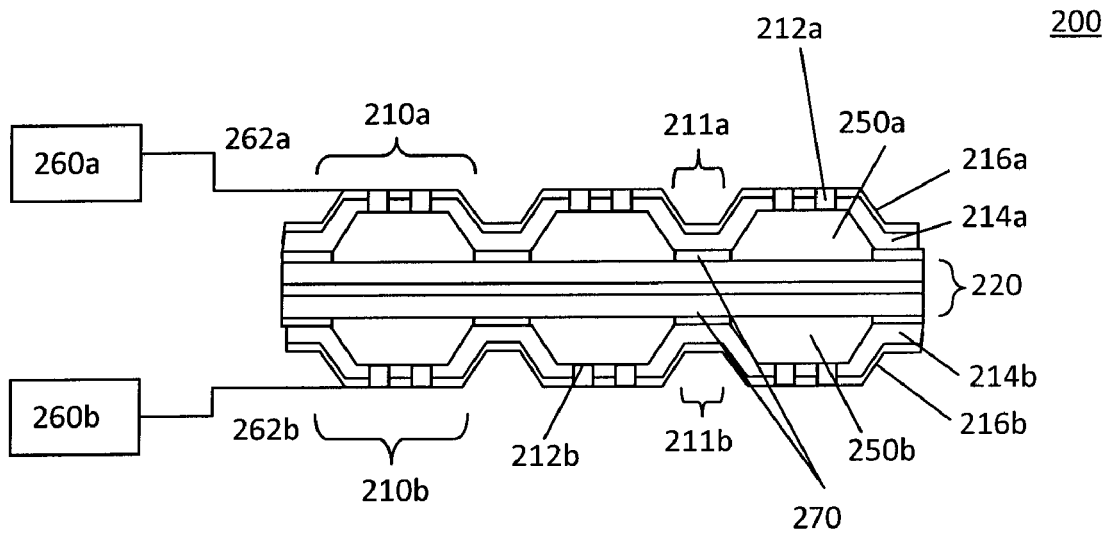

Fig. 2

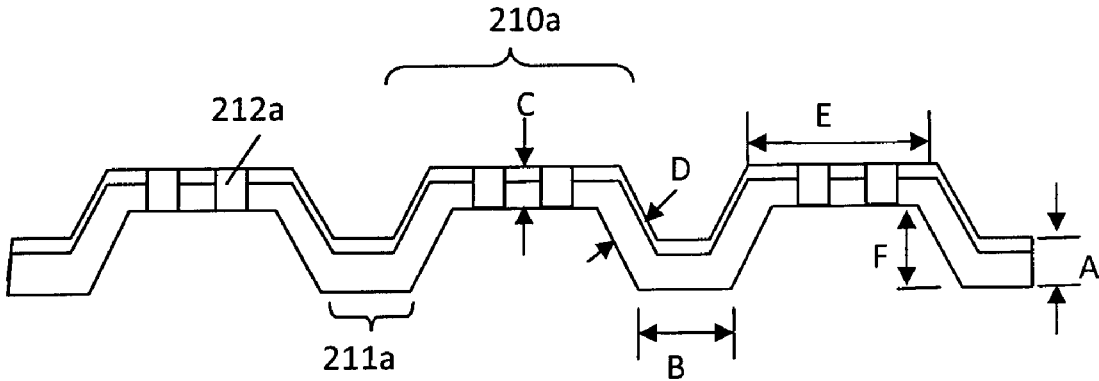

Fig. 3

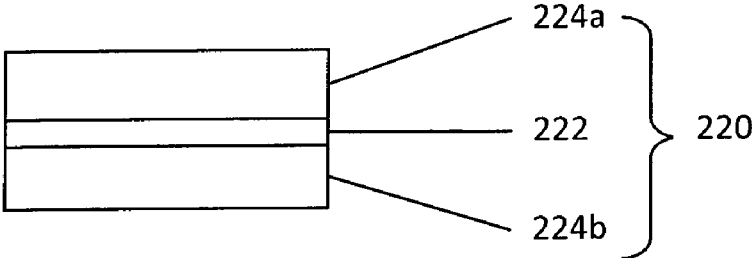

Fig. 4

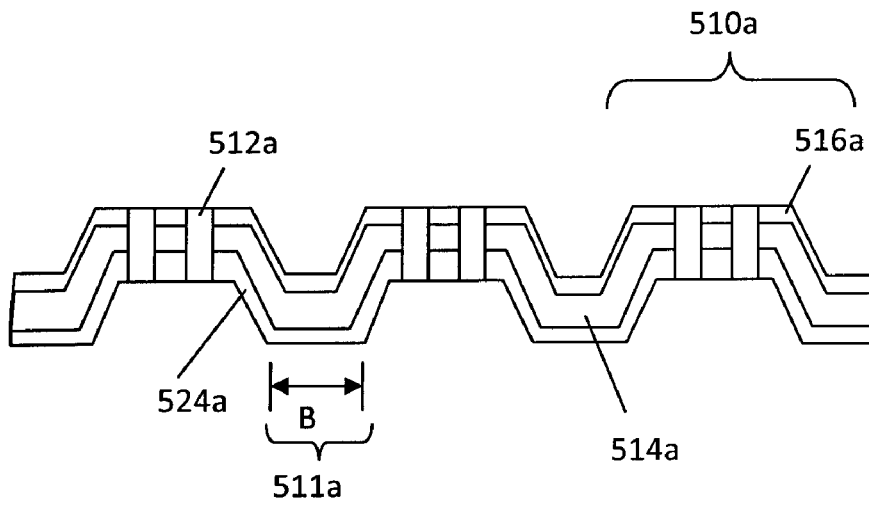

Fig. 5

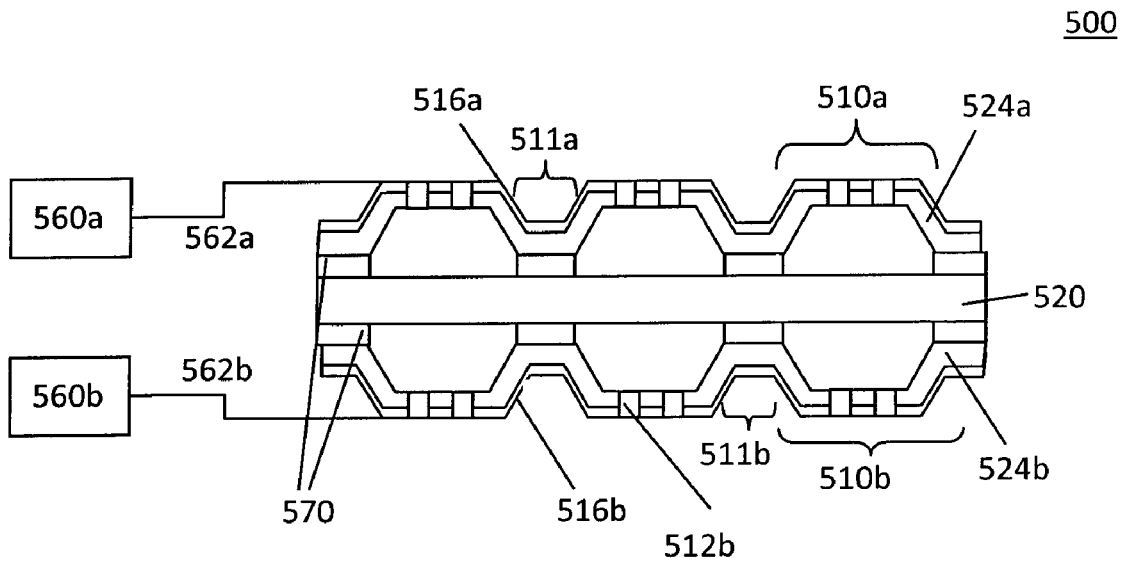

Fig. 6

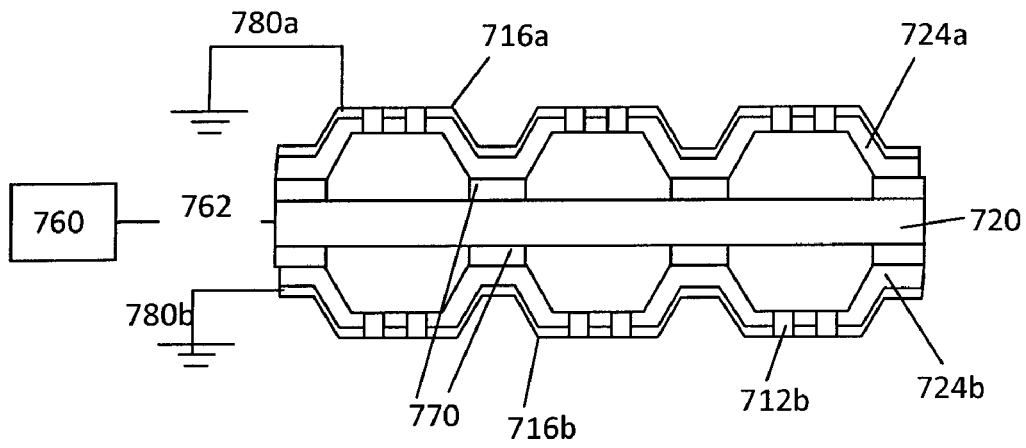

Fig. 7

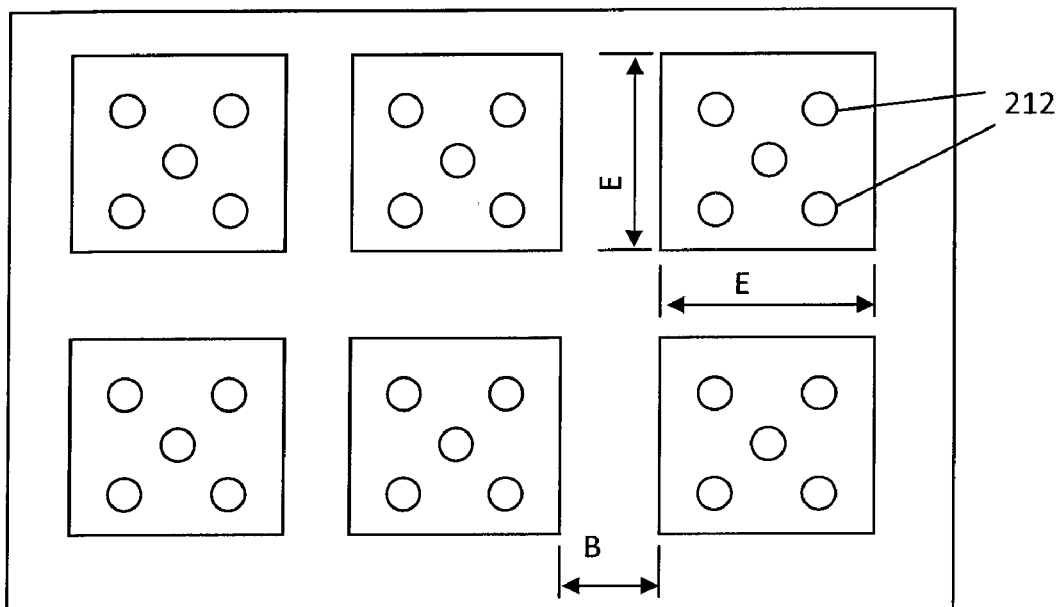

Fig. 8

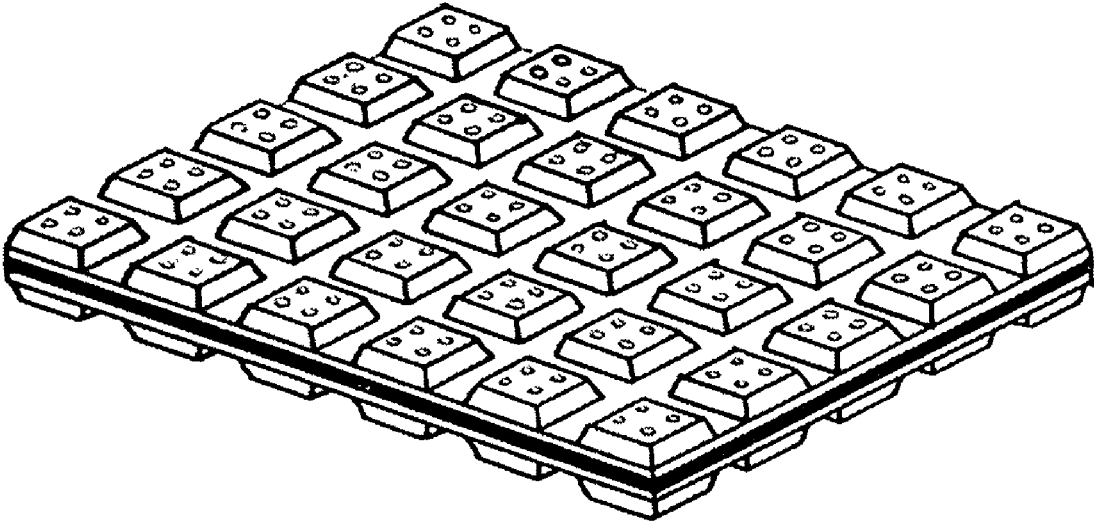

Fig. 9

FLEXIBLE ELECTRET ACTUATORS AND METHODS OF MANUFACTURING THE SAME

INCORPORATION BY REFERENCE

U.S. Provisional Patent Application No. 61/035,300, titled "Electret Materials, Electret Speakers, and Methods of Manufacturing the Same" is incorporated by reference herein.

BACKGROUND OF THE INVENTION

1. Field of the Invention

This invention relates to actuators, and more particularly, to flexible electret actuators and methods of manufacturing the same.

2. Background of the Invention

In the recent years, there have been continued developments for electronic products. One design concept for those developments has been providing lightweight, thin, portable, and/or small devices. In this regard, flexible electronic technology has been increasingly used in various applications, such as LCDs, flex circuits and flexible solar cells. Applications for flexible electronics, such as flexible speakers, may benefit from their low profile, reduced weight, and/or low manufacturing cost.

A loudspeaker may produce sound by converting electrical signals from an audio amplifier into mechanical motions. Moving-coil speakers are widely used currently, which may produce sound from the forward and backward motions of a cone that is attached to a coil of wire suspended in or movably coupled with a magnetic field. A current flowing through the coil may induce a varying magnetic field around the coil. The interaction of the two magnetic fields causes relative movements of the coil, thereby moving the cone back and forth. This compresses and decompresses the air, and thus generating sound waves. Due to structural limitations, moving-coil speakers are less likely to be made flexible or in a low profile.

An electrostatic speaker may operate on the principle of Coulomb's law that two conductors with equal and opposite charge may generate a push-pull force between them. The push-pull electrostatic force may cause vibration of a diaphragm, thereby generating sound. An electrostatic speaker may include two porous electrodes and a diaphragm placed between the electrodes to form a series of capacitors. The electrodes and the diaphragm may be separated by dielectric materials. The low-profile and lightweight diaphragm makes the electrostatic speaker superior to other types of speakers, such as dynamic, moving-coil or piezoelectric speakers, with respect to its transition response, expansion capability in high frequency, smoothness of sound, acoustic fidelity and low distortion.

With the simple structure, electrostatic speakers may be manufactured in various sizes to accommodate increasing demands for small and thin electronic devices. However, some electrostatic speakers may require a DC-DC converters for providing high voltage to the speakers. Considering the size, cost and power consumption of DC-DC converters, some electret materials have been developed to reduce or avoid the need of DC-DC converters.

FIG. 1 illustrates an exemplary electret speaker, which may include porous electrodes **110a** and **110b** with a number of holes **112a** and **112b** on each electrode having a porosity of at least 30 percent. The electrodes **110a** and **110b** may be made of metals or plastic materials coated with a conductive film. The holes **112a** and **112b** may be provided for allowing sound

waves to pass through them. The electret speaker may further include a diaphragm **120**, which may include a conductive layer **122** sandwiched between electret layers **124a** and **124b**. The electret layers **124a** and **124b** may store positive or negative charges. The electrodes **110a** and **110b**, and diaphragm **120** may be held in place by holding members **130a** and **130b**. Elements **140a**, **140b**, **142a** and **142b** may be made of insulating materials and may be used for separating the diaphragm **120** from the electrode plates **110a** and **110b** to form cavities **150a** and **150b** for the diaphragm **120** to vibrate.

In operating of an electret speaker of FIG. 1, each signal source **160a** and **160b** may output equal and opposite alternating signals to the electrodes **110a** and **110b** via conductive lines **162a** and **162b**. The signals may cause a time-varying electric field to develop between the electrodes **110a** and **110b** and the electret layers **124a** and **124b**, thus resulting in a push-pull force. The push-pull force may cause the diaphragm **120** to vibrate, resulting in sound waves that may pass through holes **112a** and **112b**.

BRIEF SUMMARY OF THE INVENTION

One example consistent with the invention provides a flexible actuator that may comprise a thin film and at least one first enclosure with at least one first bendable element coupled to the first enclosure. The thin film may comprise a conductive layer and a first electret layer over a first surface of the conductive layer. The thin film is configured to be bendable. The first enclosure has a first electrode layer as part of the first enclosure. The first enclosure is provided over the first electret layer with the first electrode layer being spaced apart from the first electret layer. The first electrode layer is coupled with a first terminal of an audio signal input. The thin film is configured to interact with the first enclosure in response to audio signals supplied by the audio signal input and to generate sound waves.

In another example consistent with the invention, a flexible actuator may comprise a thin film and at least one first enclosure with at least one first bendable element coupled to the first enclosure. The thin film may comprise a conductive layer. The thin film is configured to be bendable. The first enclosure has a first electrode layer and a first electret layer as part of the first enclosure. The first electrode layer is coupled with a first terminal of an audio signal input. The thin film is configured to interact with the first enclosure in response to audio signals supplied by the audio signal input and to generate sound waves.

It is to be understood that both the foregoing general description and the following detailed description are exemplary and explanatory only and are not restrictive of the invention, as claimed.

BRIEF DESCRIPTION OF THE SEVERAL VIEWS OF THE DRAWINGS

The foregoing summary, as well as the following detailed description of the invention, will be better understood when read in conjunction with the appended, exemplary drawings. It should be understood, however, that the invention is not limited to the precise arrangements and instrumentalities shown.

In the drawings:

FIG. 1 is a sectional view of an exemplary electret speaker in the prior art;

FIG. 2 is a sectional view of an exemplary flexible electret actuator in examples consistent with the present invention;

FIG. 3 is a detailed section view of portions of an exemplary flexible electret actuator in examples consistent with the present invention;

FIG. 4 is a detailed section view of portions of an exemplary flexible electret actuator in examples consistent with the present invention;

FIG. 5 is a sectional view of an exemplary flexible electret actuator in examples consistent with the present invention;

FIG. 6 is a sectional view of an exemplary flexible electret actuator in examples consistent with the present invention;

FIG. 7 is a sectional view of an exemplary flexible electret actuator in examples consistent with the present invention;

FIG. 8 is a top view of an exemplary application of an exemplary flexible electret actuator in examples consistent with the present invention; and

FIG. 9 is a side view of an exemplary application of an exemplary flexible electret actuator in examples consistent with the present invention.

DETAILED DESCRIPTION OF THE INVENTION

FIG. 2 illustrates an exemplary flexible electret actuator in examples consistent with the present invention. Referring to FIG. 2, the flexible electret actuator **200** may comprise first enclosures **210a**, a first bendable elements **211a**, second enclosures **210b**, second bendable elements **211b** and an electret diaphragm **220**. The first enclosures **210a** and the first bendable elements **211a** may comprise a first flexible layer **214a** and a first electrode **216a**. The second enclosures **210b** and the second bendable elements **211b** may comprise a second flexible layer **214b** and a second electrode **216b**. The flexible layers **214a** and **214b** may be made of plastic materials with plasticity or blended fibers. In one example, the flexible layers **214a** and **214b** may be made of metal meshes or thin metal plates. The thickness of each flexible layer **214a** and **214b** may be in a range of about 20 micrometers to about 10,000 micrometers. The flexible layers **214a** and **214b** may be made by at least one of the processes, including but not limited to, injection molding, pressing, forging, plastic thermoforming, mechanical manufacturing and continuous roll-to-roll processes. The first and second electrodes **216a** and **216b** may be made from conductive materials such as gold, silver, aluminum, copper, chromium, platinum, indium tin oxide (ITO), silver paste, carbon paste or other conductive materials, or a combination of some of them. The thickness of each electrode **216a** and **216b** may be in a range of about 0.01 micrometers to about 100 micrometers. The first and second electrodes **216a** and **216b** may be coated on the first and second flexible layers **214a** and **214b** by, for example, spraying-coating, spin-coating, dip-coating, sputtering, evaporation, electroplating or a screen-printing process. When the flexible layers **214a** and **214b** may be made of metal meshes or thin metal plates to remove the need for the first and second electrodes **216a** and **216b** in some examples.

FIG. 3 shows details of the first enclosures **210a** and the first bendable elements **211a**. Note that the second enclosures **210b** and second bendable element **211b** may have corresponding configuration as described below. Each first enclosure **210a** may have an upper portion with a width C, side portions with a width D and a number of acoustic holes **212a** on the upper portion. The upper portion and the side portions of each first enclosure **210a** may provide a cavity **205a** (圖 3 未標示?) with a width E and a length F. Each first bendable element **211a** with a width B may have a thickness of A. The first bendable element **211a** maybe made of bendable materials while the upper portion and the side portions of the first enclosures **210a** may be made of rigid materials. As such,

when the flexible electret actuator **200** is bent, the length F of the cavity **250a** defined by the upper portion and the side portions remains the same. In other words, the first enclosures are substantially rigid to limit spacing variation between each first enclosure and the thin film area covering by the first enclosures when the flexible actuator is bent.

FIG. 4 shows the electret diaphragm **220** which may include a conductive layer **222**, a first electret layer **224a** and a second electret layer **224b**. The conductive layer **222** may be made of gold, silver, aluminum, copper, chromium, platinum, indium tin oxide (ITO), silver paste, carbon paste or other conductive materials, or a combination of some of them. The conductive layer **222** may be coated on the electret layer **224b** by, for example, spraying-coating, spin-coating, dip-coating, sputtering, evaporation, electroplating or a screen-printing process. In one example, the electret layers **224a** and **224b** may be made of at least one of the following materials: fluorinated ethylene propylene (FEP), poly tetrafluoroethylene (PTFE), cyclic olefin copolymer (COC), polychlorotrifluoroethylene (PCTFE), poly(ethylene-tetrafluoroethylene) (ETFE), Teflon AF, polyimide (PI), polyetherimide (PEI), polystyrene (PS), polycarbonate (PC), polymethylmethacrylate (PMMA), polyvinyl chloride (PVC), and tetrafluoroethylene-per-fluoromethoxyethylene copolymer (PFA). The electret layers **224a** and **224b** may store either positive charges or negative charges. The electret layers **224a** and **224b** may improve its charge storage stability by corona charge. The electret-metal-electret structure of the diaphragm **220** may be fabricated by a conventional process. In one example, the electret layer **224a** may be formed on the conductive layer **222** and the electret layer **224b** through vacuum thermal compression, ultrasonic pressing, mechanical compression or a roll-to-roll process to form an electret-metal-electret structure.

The electret diaphragm **220** may be placed between the first enclosures **210a** and the second enclosures **210b** by a process, such as a roll-to-roll pressing process or a large-area imprinting process. In that regard, the electret-metal-electret structure of the diaphragm **220** may be affixed to portions of the first bendable elements **211a** and the second bendable elements **211b**. In one example, the diaphragm **220** may be affixed to the first and second enclosures **210a** and **210b** by, for example, a thermal pressing process, ultrasonic pressing process, vacuum thermal compression, a roll-to-roll process or mechanical compression. In another example, the diaphragm **220** may be affixed to the first and second enclosures **210a** and **210b** by an adhesive element **270** (as shown in FIG. 2). In one example, the adhesive element **270** may be a double-sided adhesive tape, epoxy resin or instant adhesive glues. The first and second bendable elements **211a** and **211b** may hold and support the diaphragm **220** to provide its tension. Referring again to FIG. 2, the first enclosure **210a**, the second enclosure **210b** and the diaphragm **220** together provide a first cavity **250a** and a second cavity **250b** to ensure the efficiency of the diaphragm **220** and its displacement. The assembly of the first and second enclosures **210a** and **210b** and the diaphragm **220** may form a single unit of a flexible electret actuator **200**. A number of the units arranged together may constitute a flexible electret actuator as shown in FIGS. 8 and 9.

In operation of a flexible electret actuator **200** of FIG. 2, each signal source **260a** and **260b** may output an equal and opposite alternating signal to the electrodes **216a** and **216b** via conductive lines **262a** and **262b**. The signals may cause a time-varying electric field to develop between the electrodes **216a** and **216b** and the electret layers **224a** and **224b**, thus resulting in a push-pull force. The push-pull force may cause

the diaphragm **220** to vibrate. The resultant sound waves may pass through holes **212a** and **212b** and thus generating sound.

Another example consistent with the present invention provides a flexible electret actuator wherein the electret layer is included as part of the first enclosures and the first bendable element. In this example, a flexible electret actuator may include first enclosures **510a**, first bendable elements **511a**, second enclosures **510b** and second bendable elements **511b**. FIG. **5** shows details of the first enclosures **510a** which may include an electrode **516a**, a flexible layer **514a**, an electret layer **524a**, and acoustic holes **512a**. Since the flexible layer **514a**, the electret layer **524a**, the electrode **516a** and the acoustic holes **512a** are same as those corresponding elements described in connection with FIGS. **2-4**, description of these elements will not be repeated. In this example, the electret layer **524a** may be provided under the flexible layer **514a** by at least one of the processes, including spraying, ultrasonic pressing process, thermal pressing process or mechanical compression. When the electret layer **524a** is made of plastic with plasticity, the flexible layer **514a** may be omitted as shown in FIG. **6**. In the examples of FIGS. **5** and **6**, the electrostatic charges stored in electret layers **524a** and **524b** may be positive or negative.

Referring to FIG. **6**, the diaphragm **520** may be made of at least one of the following materials: fluorinated ethylene propylene (FEP), cyclic olefin copolymer (COC), polyimide (PI), polyetherimide (PEI), polystyrene (PS), polycarbonate (PC), polymethylmethacrylate (PMMA), polyvinyl chloride (PVC), and poly(ethylene terephthalate (PET). The thickness of the diaphragm **520** may be in a range of about 0.5 micrometers to about 200 micrometers. The diaphragm **520** may be coated with a conductive film to form a conductive diaphragm **520** by, for example, a spraying-coating, spin-coating, dip-coating, sputtering, evaporation, electroplating or screen-printing process. In one example, the conductive layer may be gold, silver, aluminum, copper, chromium, platinum, indium tin oxide (ITO), silver paste, carbon paste or other conductive materials.

Referring again to FIG. **6**, the conductive diaphragm **520** may be affixed to portions of the first bendable element **511a** and the second bendable element **511b** in the same way as described in connection with FIGS. **2-4** above. In addition, a flexible electret actuator **500** of FIG. **6** operates the same as described in connection with FIGS. **2-4**.

FIG. **7** illustrates another example in consistent with the present invention. The flexible electret actuator **700** is the same as the flexible electret actuator **500** of FIG. **6** except that one of the electret layers **724a** and **724b** stores positive charge and the other stores negative charges. In this example, electrodes **716a** and **716b** are connected to ground via conductive lines **780a** and **780b**. In operation of a flexible electret actuator of FIG. **7**, the signal source **760** may output an alternating signal to the conductive diaphragm **720** via conductive line **762**. The signal may cause a time-varying electric field to develop between the conductive diaphragm **720** and the electret layers **724a** and **724b**, thus resulting in a push-pull force. The push-pull force may cause the diaphragm **720** to vibrate. The resultant sound waves may pass through holes **712a** and **712b** and thus generating sound.

It will be appreciated by those skilled in the art that changes could be made to the examples described above without departing from the broad inventive concept thereof. It is understood, therefore, that this invention is not limited to the particular examples disclosed, but it is intended to cover modifications within the spirit and scope of the present invention as defined by the appended claims.

We claim:

1. A flexible actuator, comprising: a thin film comprising a conductive layer and a first electret layer over a first surface of the conductive layer, the thin film is configured to be bendable; and at least one first enclosure having a plurality of protrusion portions with at least one first bendable element which is conformally coupled onto the first enclosure and being a connecting part of the first enclosure to connect to the thin film, the first enclosure having a first electrode layer and being provided over the first electret layer with the first electrode layer being spaced apart from the first electret layer and a plurality of separated cavities formed between the plurality of protrusion portions and the thin film, the first electrode layer being coupled with a first terminal of an audio signal input, wherein the thin film is configured to interact with the first enclosure in response to audio signals supplied by the audio signal input and to generate sound waves.

2. The flexible actuator of claim **1**, wherein the plurality of protrusion portions of the at least one first enclosure is substantially rigid to limit spacing variation between the first enclosure and thin film area covered by the first enclosure when the flexible actuator is bent.

3. The flexible actuator of claim **1**, wherein the at least one first enclosure comprises a number of openings for allowing the sound waves to pass through.

4. The flexible actuator of claim **1**, wherein the at least one first enclosure is provided over the thin film with an adhesive layer between a portion of the first bendable element and the thin film.

5. The flexible actuator of claim **1**, wherein the at least one first enclosure is provided over the thin film by at least one of ultrasonic pressing, thermal pressing, vacuum thermal compression, mechanical compression, and a roll-to-roll process.

6. The flexible actuator of claim **1**, wherein the at least one first enclosure and the at least one first bendable element comprise a first flexible layer made of at least one of plastic materials with plasticity and blended fibers at different thicknesses.

7. The flexible actuator of claim **6**, wherein the first flexible layer is in a thickness between about 20 micrometers and 10,000 micrometers.

8. The flexible actuator of claim **1**, further comprising at least one second enclosure having a plurality of protrusion portions with at least one second bendable element which is conformally coupled onto the second enclosure and being a connecting part of the second enclosure to connect to the thin film, the second enclosure having a second electrode layer and being provided over the thin film at a side opposed to the first enclosure with the second electrode layer being spaced apart from the thin film and a plurality of separated cavities being formed between the plurality of protrusion portions of the second enclosure and the thin film, the second electrode layer being coupled with a second terminal of the audio signal input, wherein the thin film is configured to interact with the first and second enclosures in response to the audio signals supplied by the audio signal input and to generate the sound waves.

9. The flexible actuator of claim **1**, further comprising at least one second enclosure having a plurality of protrusion portions with at least one second bendable element which is conformally coupled onto the second enclosure and being a connecting part of the second enclosure to connect to the thin film, the second enclosure having a second electrode layer and being provided over the thin film at a side opposed to the first enclosure with the second electrode layer being spaced apart from the thin film and a plurality of separated cavities being formed between the plurality of protrusion portions of

the second enclosure and the thin film, the second electrode layer being coupled with a terminal of a second audio signal input, wherein the thin film is configured to interact with the first and second enclosures in response to the audio signals supplied by the audio signal input and the second audio signal input and to generate the sound waves.

10. The flexible actuator of claim 1, wherein the first electrode layer is in a thickness between about 0.01 micrometers and 100 micrometers.

11. The flexible actuator of claim 1, wherein the conductive layer is made of at least one of gold, silver, aluminum, copper, chromium, platinum, indium tin oxide (ITO), silver paste, carbon paste and other conductive materials.

12. The flexible actuator of claim 1, wherein the first electret layer is made of at least one of fluorinated ethylene proylene (FEP), poly tetrafluoroethylene (PTFE), cyclic olefin copolymer (COC), polychlorotrfluoroethylene (PCTFE), poly(ethylene-tetrafluoroethylene) (ETFE), Teflon AF, polyimide (PI), polyetherimide (PEI), polystyrene (PS), polycarbonate (PC), polymethylmethacrylate (PMMA), polyvinyl chloride (PVC), and tetrafluoroethylene-per-fluoromethoxyethylene copolymer (PFA).

13. The flexible actuator of claim 1, wherein the thin film further comprises a second electret layer over a second surface of the conductive layer, wherein the conductive layer is sandwiched between the first electret layer and the second electret layer to form an electret-metal-electret structure.

14. A flexible actuator, comprising: a thin film comprising a conductive layer, the thin film being configured to be bendable; at least one first enclosure provided over the thin film with at least one first bendable element coupled to the first enclosure, the first enclosure having a first electrode layer and a first electret layer as part of the first enclosure with the first electret layer being an inner part, the first enclosure being coupled with a first terminal of an audio signal input, wherein the thin film is configured to interact with the first enclosure in response to audio signal supplied by the audio signal input and to generate sound waves.

15. The flexible actuator of claim 14, wherein the at least one first enclosure is substantially rigid to limit spacing variation between the first enclosure and thin film area covered by the first enclosure when the flexible actuator is bent.

16. The flexible actuator of claim 14, wherein the at least one first enclosure comprises a number of openings for allowing the sound waves to pass through.

17. The flexible actuator of claim 14, wherein the at least one first enclosure is provided over the thin film with an adhesive layer between a portion of the first bendable element and the thin film.

18. The flexible actuator of claim 14, wherein the at least one first enclosure is provided over the thin film by at least one of ultrasonic pressing, thermal pressing, vacuum thermal compression, mechanical compression, and a roll-to-roll process.

19. The flexible actuator of claim 14, wherein the at least one first enclosure and the first bendable element comprise a

first flexible layer made of at least one of plastic materials with plasticity and blended fibers at different thicknesses.

20. The flexible actuator of claim 19, wherein the first flexible layer is in a thickness between about 20 micrometers and 10,000 micrometers.

21. The flexible actuator of claim 14, further comprising at least one second enclosure with at least one second bendable element coupled to the second enclosure, the second enclosure being provided over the thin film at a side opposed to the first enclosure, the second enclosure having a second electrode layer and at least one second electret layer as part of the second enclosure with the second electret layer being an inner part, the second electrode layer being coupled with a second terminal of the audio signal input, wherein the thin film is configured to interact with the first and second enclosures in response to the audio signals supplied by the audio signal input and to generate the sound waves.

22. The flexible actuator of claim 14, further comprising at least one second enclosure with at least one second bendable element coupled to the second enclosure, the second enclosure being provided over the thin film at a side opposed to the first enclosure, the second enclosure having a second electrode layer and at least one second electret layer as part of the second enclosure with the second electret layer being an inner part, the second electrode layer being coupled with a terminal of a second audio signal input, wherein the thin film is configured to interact with the first and second enclosures in response to the audio signals supplied by the audio signal input and the second audio signal input and to generate the sound waves.

23. The flexible actuator of claim 14, wherein the first electrode layer is in a thickness between about 0.01 micrometers and 100 micrometers.

24. The flexible actuator of claim 14, wherein the conductive layer of the thin film is coupled with a second terminal of the audio signal input.

25. The flexible actuator of claim 14, wherein the conductive layer is made of at least one of gold, silver, aluminum, copper, chromium, platinum, indium tin oxide (ITO), silver paste, carbon paste and other conductive materials.

26. The flexible actuator of claim 14, wherein the first electret layer is made of at least one of fluorinated ethylene proylene (FEP), poly tetrafluoroethylene (PTFE), cyclic olefin copolymer (COC), polychlorotrfluoroethylene (PCTFE), poly(ethylene-tetrafluoroethylene) (ETFE), Teflon AF, polyimide (PI), polyetherimide (PEI), polystyrene (PS), polycarbonate (PC), polymethylmethacrylate (PMMA), polyvinyl chloride (PVC), and tetrafluoroethylene-per-fluoromethoxyethylene copolymer (PFA).

27. The flexible actuator of claim 14, wherein the at least one first enclosure has a plurality of protrusion portions which provides a plurality of separated cavities formed between the plurality of protrusion portions and the thin film.

* * * * *