

UNITED STATES PATENT AND TRADEMARK OFFICE
CERTIFICATE OF CORRECTION

PATENT NO. : 10,566,945 B2
APPLICATION NO. : 15/795764
DATED : February 18, 2020
INVENTOR(S) : Tzong-Lin Wu, Ying-Cheng Tseng and Yen-Ju Lin

Page 1 of 1

It is certified that error appears in the above-identified patent and that said Letters Patent is hereby corrected as shown below:

On the Title Page

Item (72) Inventors should be corrected to read:

Tzong-Lin Wu, Taipei (TW);
Ying-Cheng Tseng, Taipei (TW);
Yen-Ju Lin, Taipei City (TW)



Signed and Sealed this
Thirty-first Day of January, 2023
Katherine Kelly Vidal

Katherine Kelly Vidal
Director of the United States Patent and Trademark Office



US010566945B2

(12) **United States Patent**
Wu et al.

(10) **Patent No.:** **US 10,566,945 B2**
(45) **Date of Patent:** **Feb. 18, 2020**

- (54) **NOISE SUPPRESSION DEVICE AND EQUIVALENT CIRCUIT THEREOF**
- (71) Applicant: **NATIONAL TAIWAN UNIVERSITY, Taipei (TW)**
- (72) Inventors: **Tzong-Lin Wu, Taipei (TW); Ying-Cheng Tseng, Taipei (TW)**
- (73) Assignee: **National Taiwan University, Taipei (TW)**

- (56) **References Cited**
- U.S. PATENT DOCUMENTS
- 6,061,227 A * 5/2000 Nogi H01G 4/385 333/185
- 8,121,544 B2 2/2012 Shimizu et al.
- 8,595,924 B2 12/2013 McKinzie, III
- 8,994,470 B2 3/2015 Sakai
- (Continued)

(*) Notice: Subject to any disclaimer, the term of this patent is extended or adjusted under 35 U.S.C. 154(b) by 103 days.

- FOREIGN PATENT DOCUMENTS
- TW 1476787 B 3/2015
- TW 1483453 B 5/2015
- TW 1530093 B 4/2016

(21) Appl. No.: **15/795,764**

OTHER PUBLICATIONS

(22) Filed: **Oct. 27, 2017**

Yen-Ju Lin, Ying-Cheng Tseng, and Tzong-Lin Wu, "A Resonator-Based Suppressor for Mitigating the Noise Transfer on Metal Plates for Control of Electromagnetic Interference", IEEE Microwave and Wireless Components Letters, vol. 26, No. 11, Nov. 2016.

(65) **Prior Publication Data**
US 2018/0316332 A1 Nov. 1, 2018

Primary Examiner — Rakesh B Patel
(74) *Attorney, Agent, or Firm* — Rosenberg, Klein & Lee

(30) **Foreign Application Priority Data**
Apr. 27, 2017 (TW) 106114139 A

(57) **ABSTRACT**

(51) **Int. Cl.**
H03H 7/06 (2006.01)
H03H 7/01 (2006.01)
H03H 1/00 (2006.01)

(52) **U.S. Cl.**
 CPC **H03H 7/1758** (2013.01); **H03H 1/00** (2013.01); **H03H 7/06** (2013.01); **H03H 2001/0021** (2013.01)

The present invention provides a noise suppression device and equivalent circuit thereof. The noise suppression device comprises a metal plate and at least one first resonance unit. The first resonance unit comprises a plurality of first resonators. Each of the first resonators comprises a first metal segment and at least one first conductive connection segment, the first metal segment is connected to the first conductive connection segment. When the first resonance unit is configured on the metal plate, each of the first metal segments is electrically connected to the metal plate by the corresponding first conductive connection segment. When the resonance of the first resonator occurs, a noise transmitted on the metal plate can be conducted to the first resonator and suppressed by the first resonator.

(58) **Field of Classification Search**
 CPC H03H 2001/0085; H03H 1/0007; H03H 7/06; H03H 7/1758
 USPC 333/181, 185
 See application file for complete search history.

22 Claims, 16 Drawing Sheets

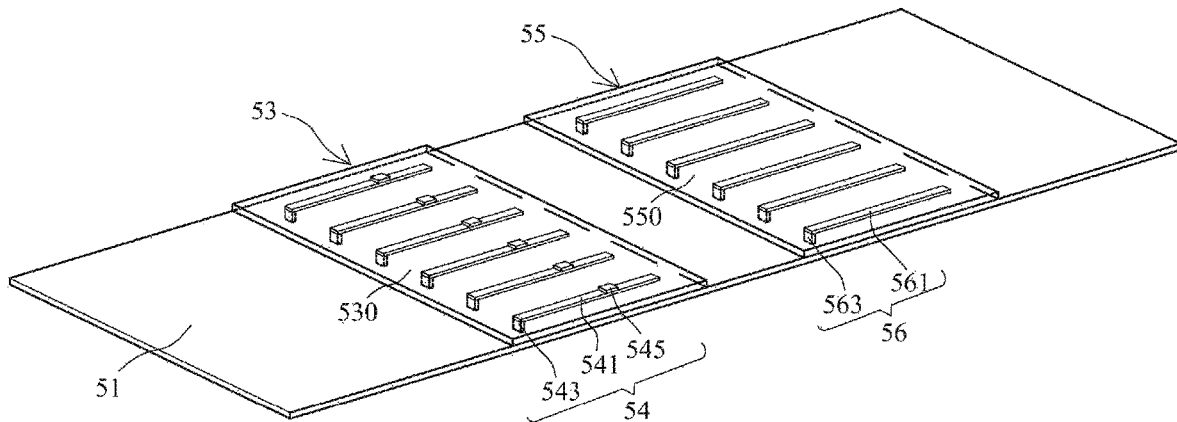

(56)

References Cited

U.S. PATENT DOCUMENTS

8,994,477	B2	3/2015	Wu et al.
9,257,955	B2	2/2016	Wu et al.
2007/0035355	A1	2/2007	Chao
2014/0132371	A1	5/2014	Hankui
2015/0041185	A1	2/2015	Chiu et al.

* cited by examiner

500

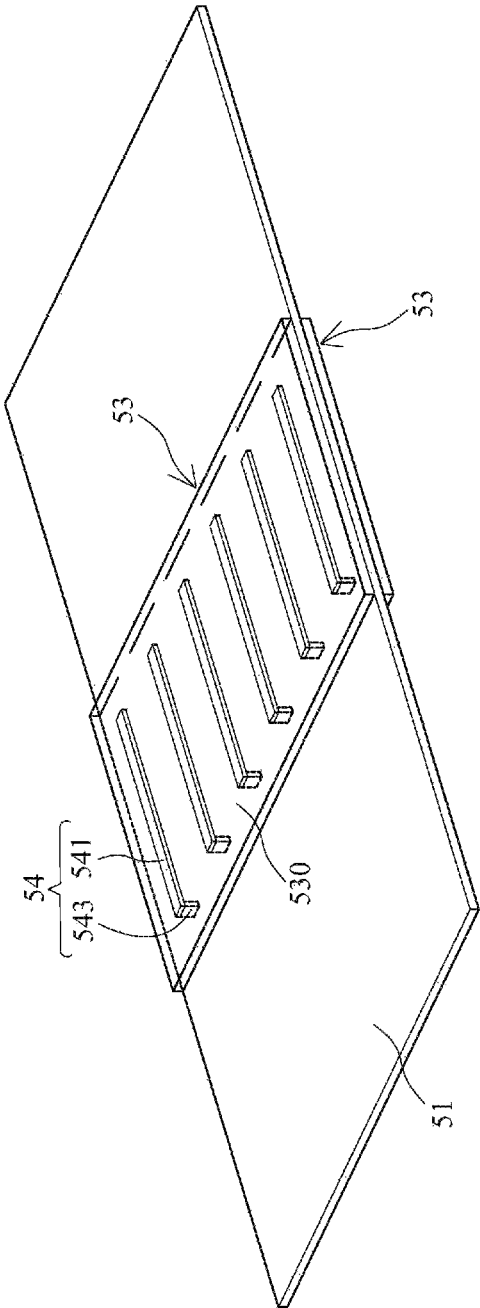

Fig. 1

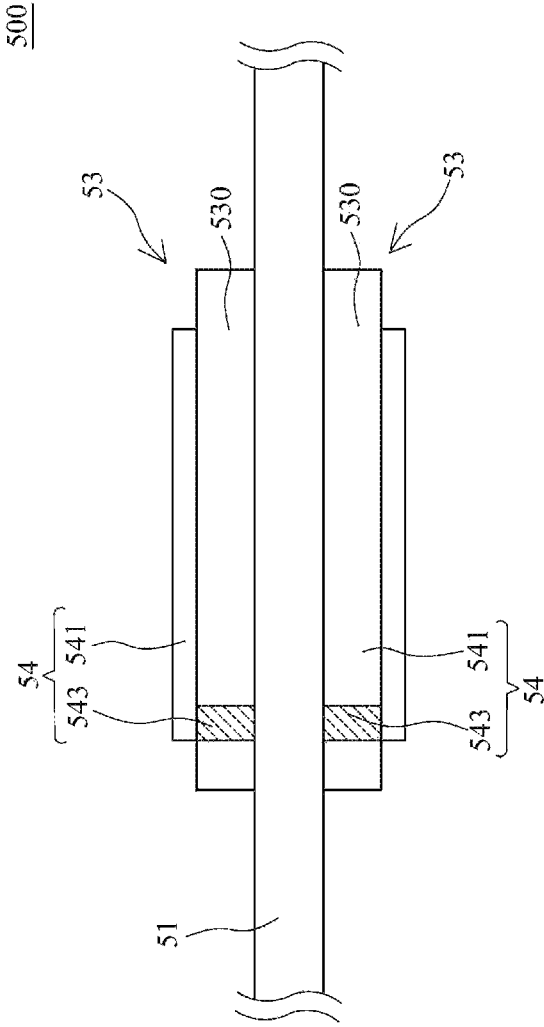

Fig. 2

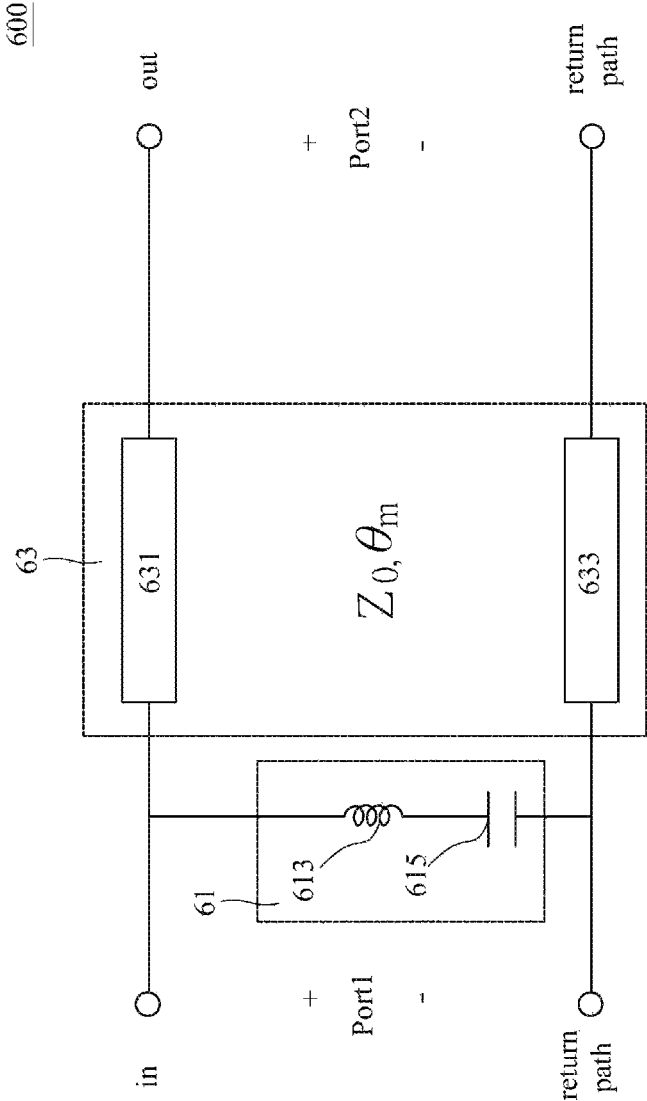

Fig. 3

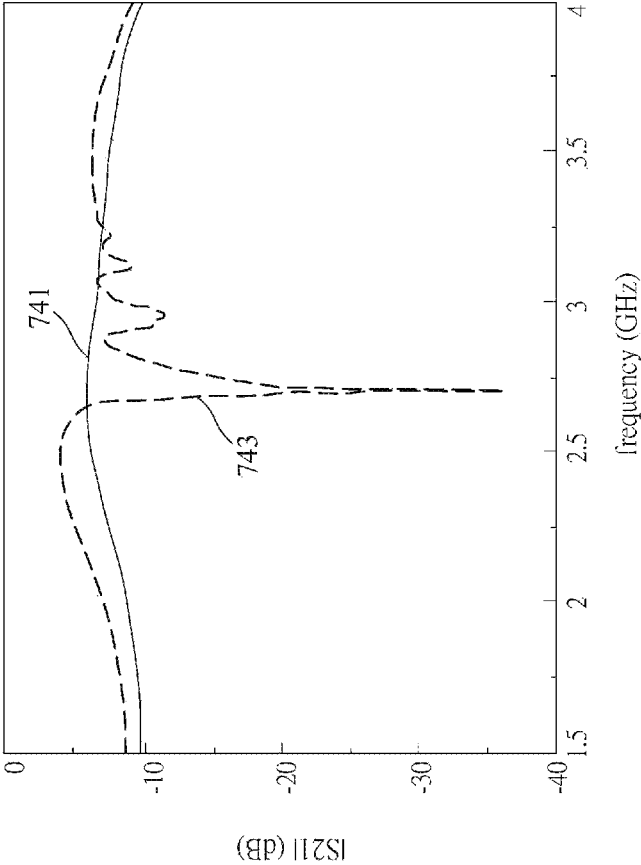

Fig. 4

501

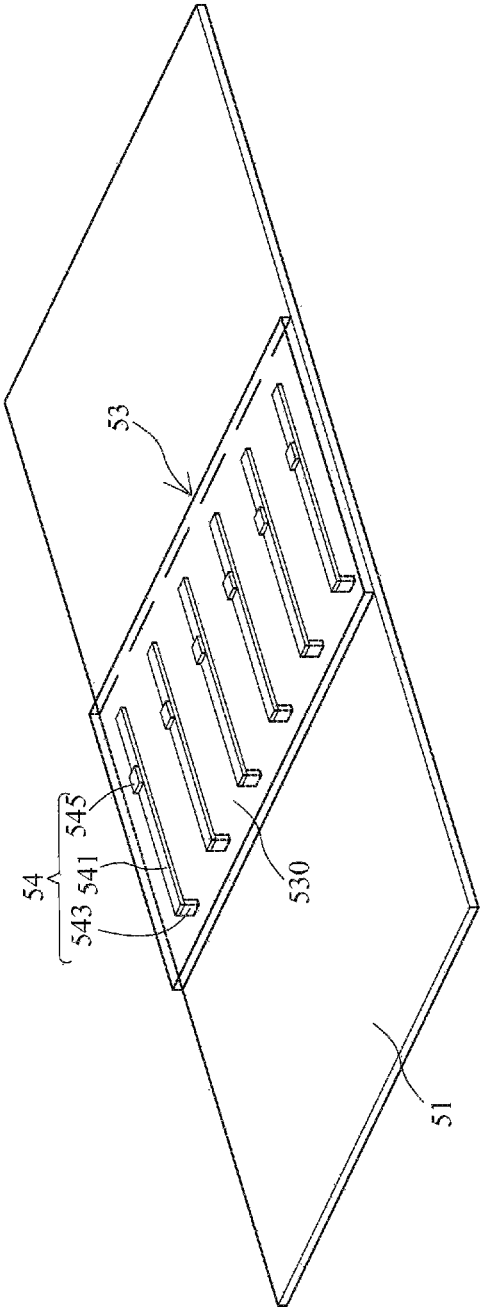

Fig. 5

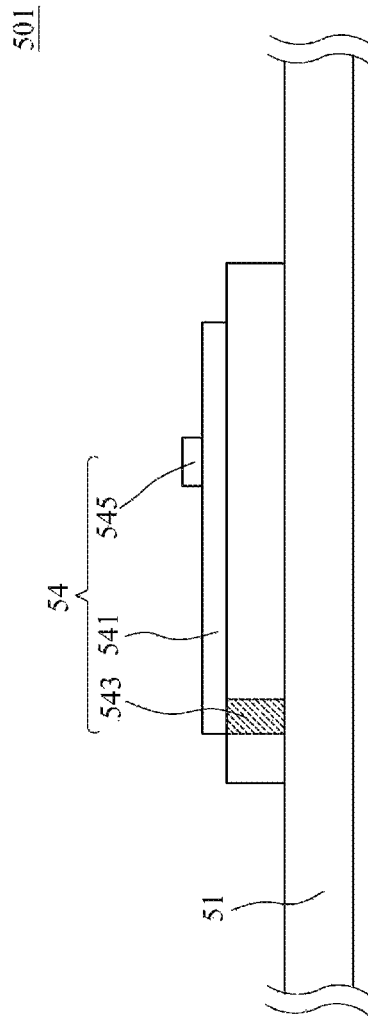

Fig. 6

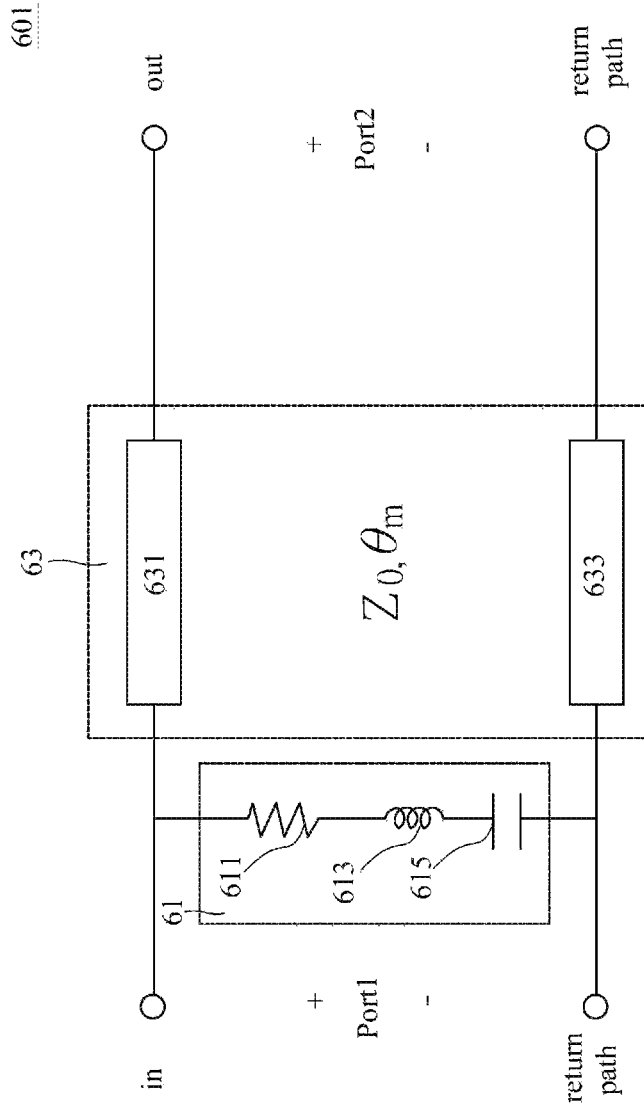

Fig. 7

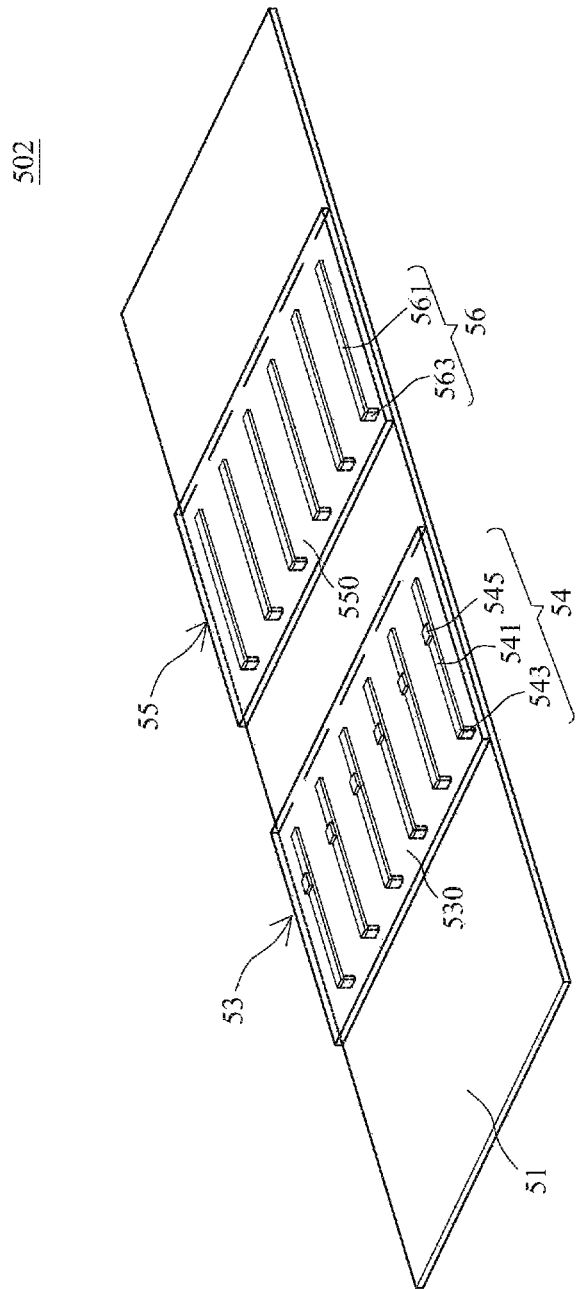

Fig. 8

502

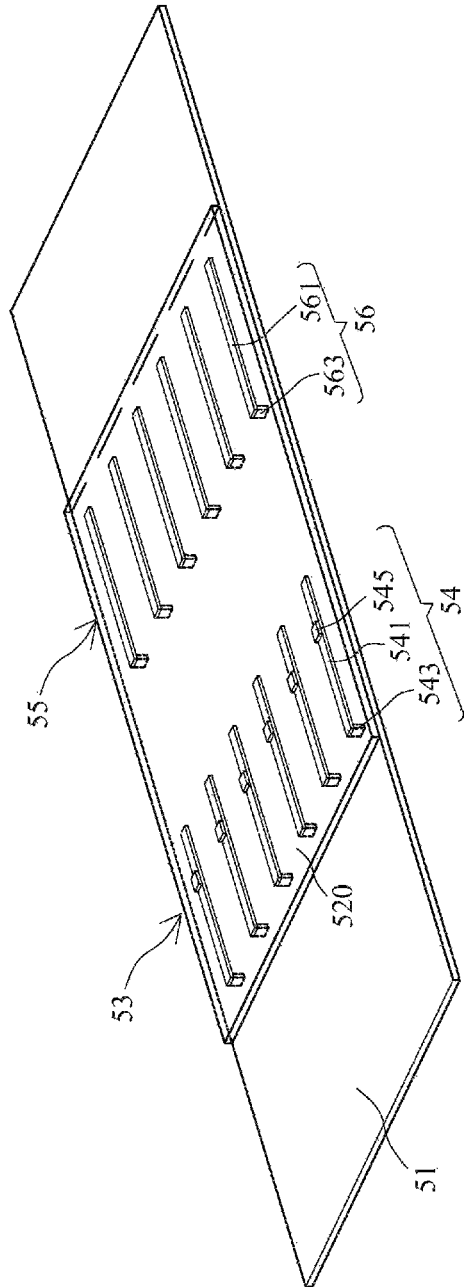

Fig. 9

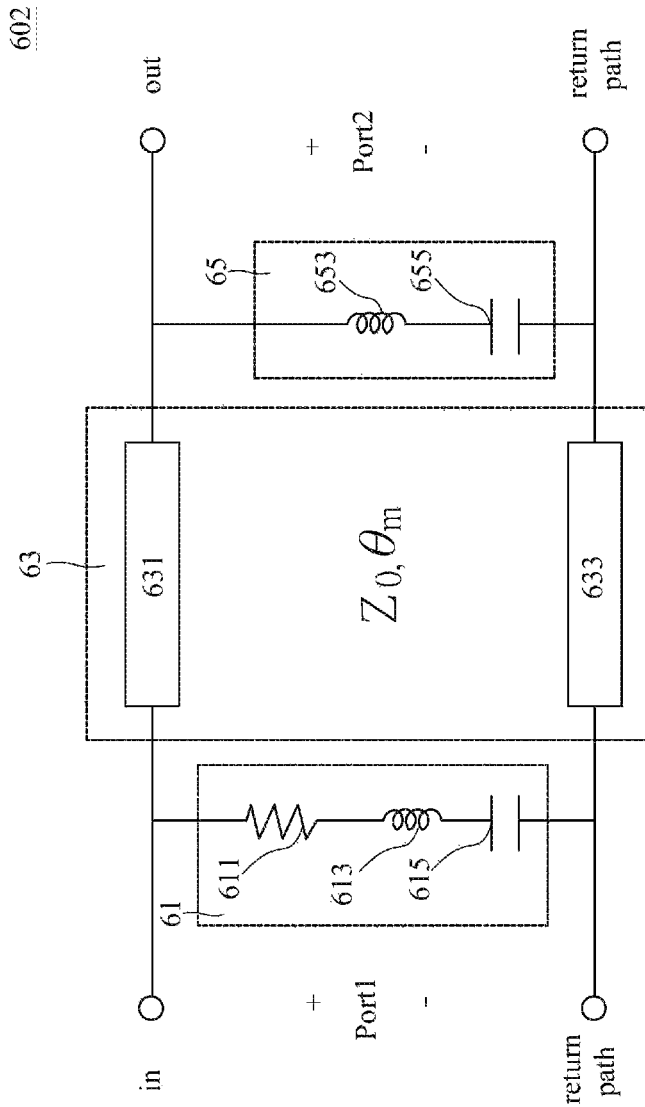

Fig. 10

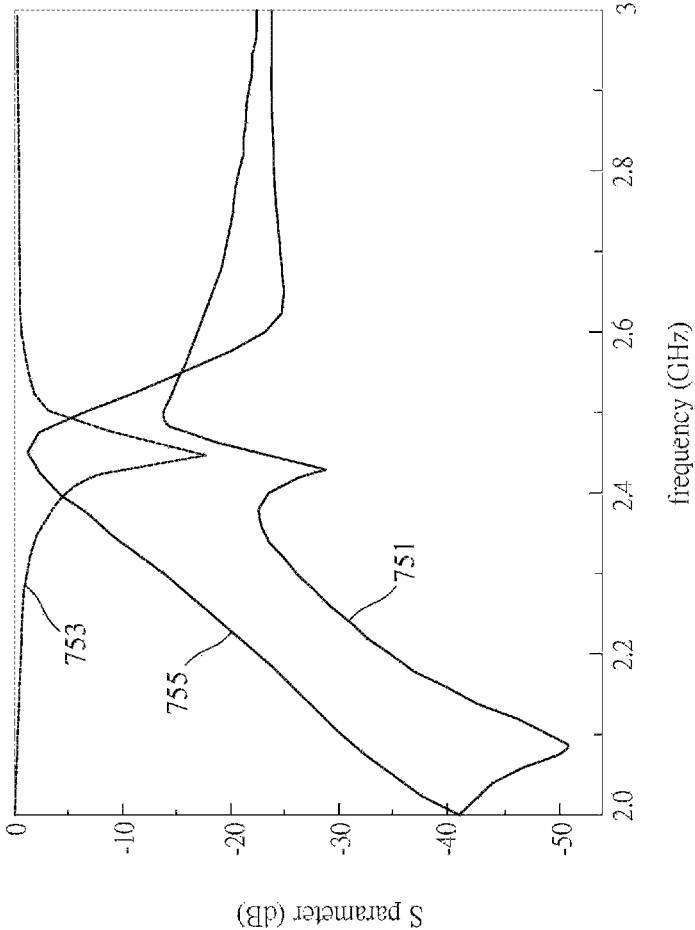

Fig. 11

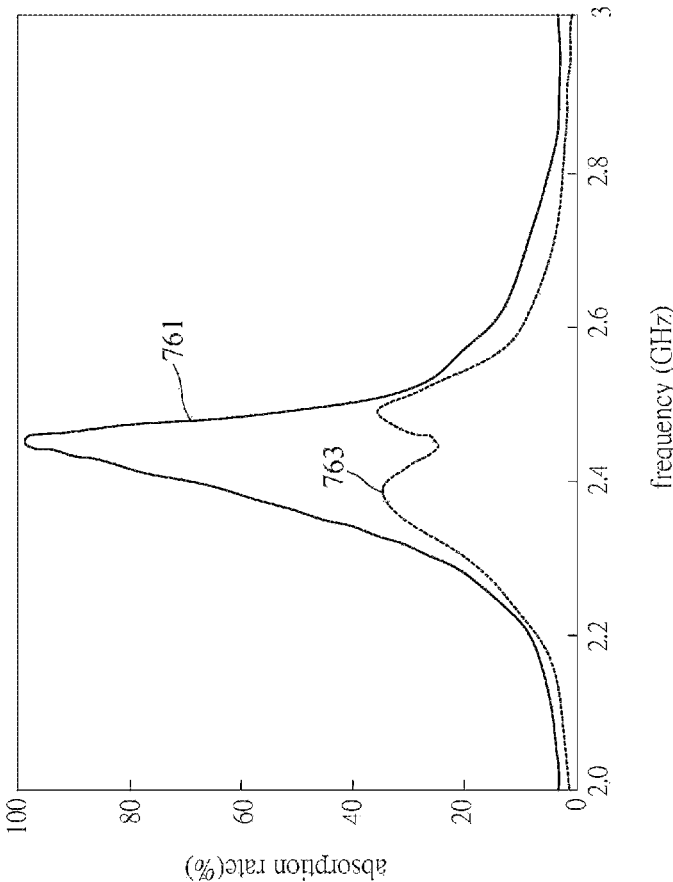

Fig. 12

503

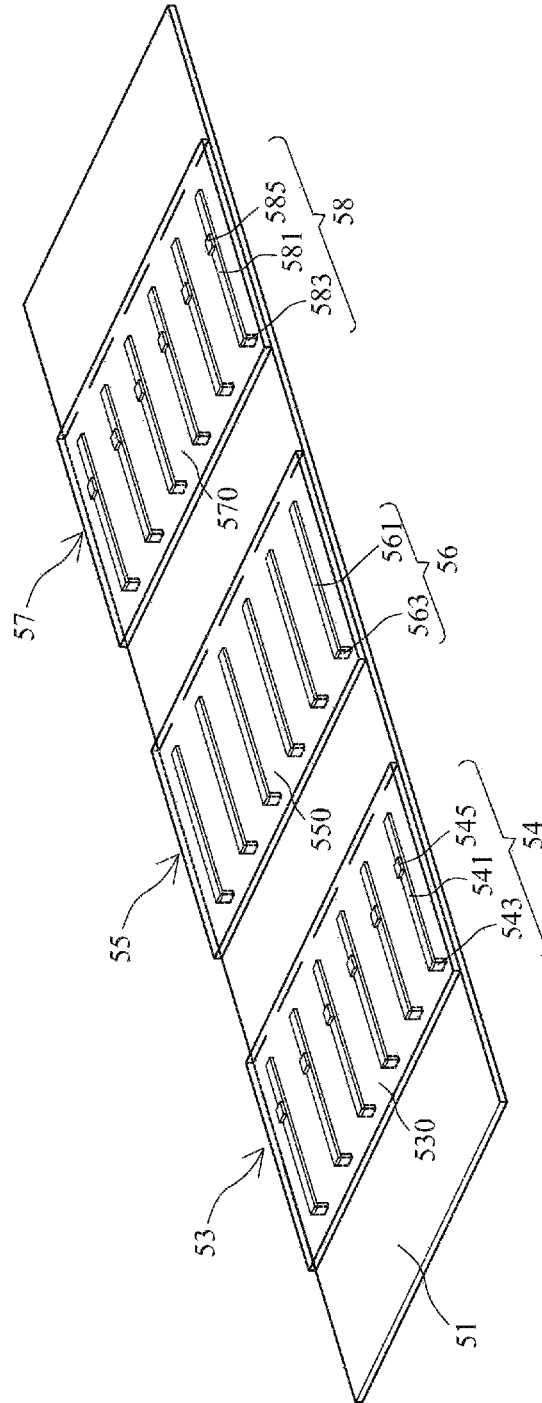

Fig. 13

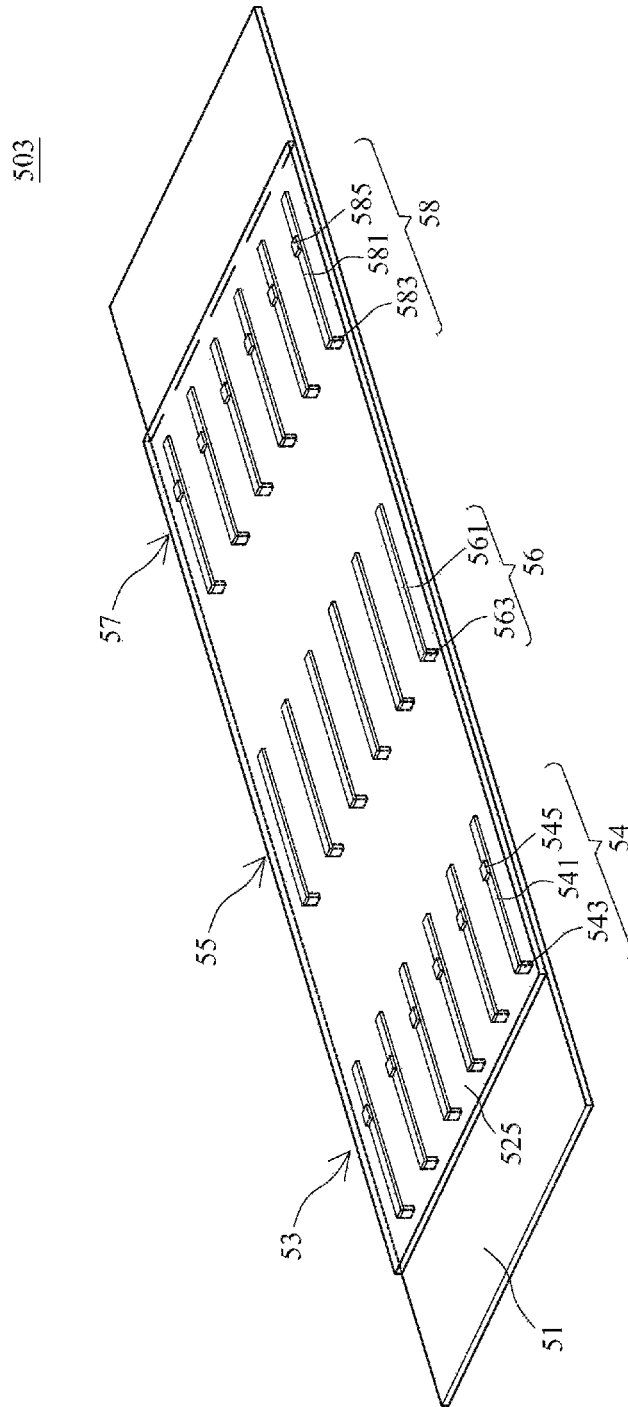

Fig. 14

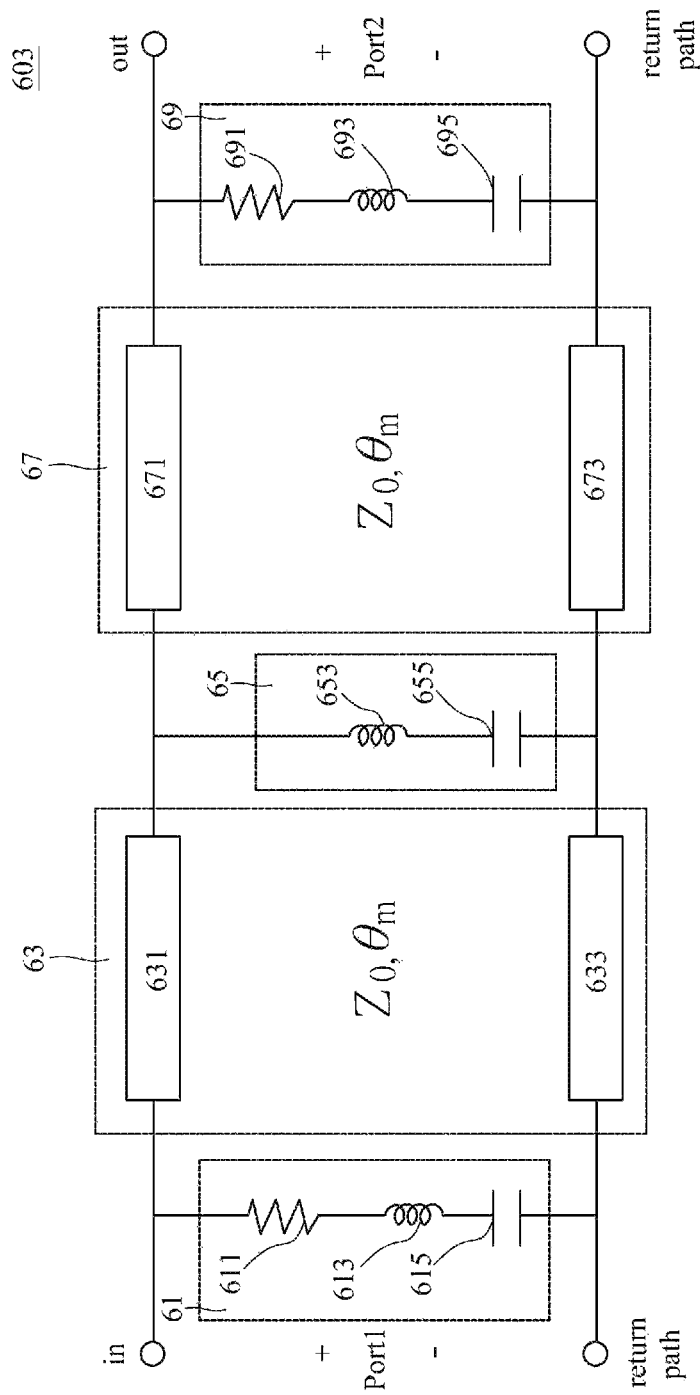

Fig. 15

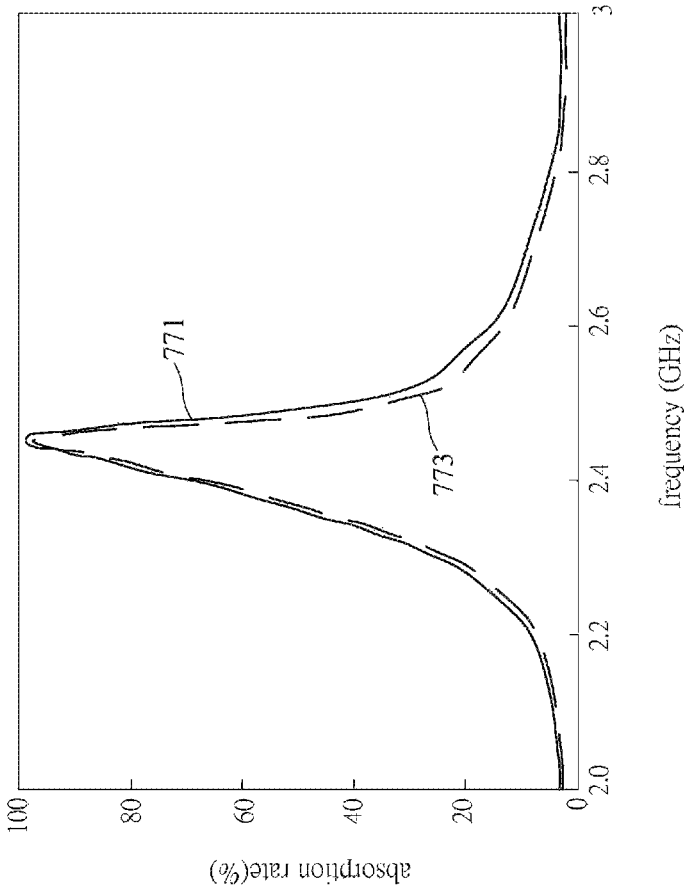

Fig. 16

NOISE SUPPRESSION DEVICE AND EQUIVALENT CIRCUIT THEREOF

This non-provisional application claims priority claim under 35 U.S.C. § 119 (a) on Taiwan Patent Application No. 106114139 filed Apr. 27, 2017, the entire contents of which are incorporated herein by reference.

FIELD OF THE INVENTION

The present invention is related to a suppression device and equivalent circuit thereof, particularly to a suppression device and equivalent circuit thereof for suppressing a noise.

BACKGROUND

With the development of science and technology, the transmission speed of the signal is faster. When the signal traces passes through a discontinuous structure or non-ideal circuit structures, for example, holes passed through multi-layered, blended signal trajectory, and the interface connector, it will easily generate noises, and therefore cause serious electromagnetic interference (EMI) or radio frequency interference (RFI). When the EMI or RFI occurs, the operation of the electrical elements within the electrical product will be affected.

To solve the problem of EMI, in the past, it is more common to use an electromagnetic material, for example, common-mode choke (CMC), in which the feature of high inductance of electromagnetic material is used to suppress the generation of EMI. However, the permeability of the electromagnetic material attenuates quickly in high frequency, in which condition makes the electromagnetic material not suitably in high-speed transmission interface with frequency section of GHz or above.

In view of the above, the present invention is provided with a novel noise suppression device, which has a higher noise suppressing ability, and can easily adjust the target frequency band to be suppressed, it will be the object to be achieved by the present invention.

SUMMARY

It is one object of the present invention to provide a noise suppression device, which comprises a metal plate and at least one resonance unit having a plurality of resonators, the resonance unit is connected to the metal plate, when the resonance unit occurs resonant, a noise transmitted by the metal plate will be conducted to the resonance unit and suppressed by the resonance unit.

It is another object of the present invention to provide a noise suppression device, wherein each of the resonators of the resonance unit is configured with at least one resistor, when the noise transmitted on the metal plate is conducted to the resonance unit, the energy of the noise will be absorbed or dissipated by the resistors of the resonance unit.

It is another object of the present invention to provide a noise suppression device, wherein the noise suppression device is provided at an input end thereof with a resonance unit of an absorption type, and provided at an output end thereof with other resonance unit of an absorption type, accordingly, the noise suppression device can achieve the effect for bidirectional absorbing the noise via the resonance units provided at the input end and the output end.

For achieving above objects, the present invention provides a noise suppression device, which is applied in an electronic product, the noise suppression device comprising:

a metal plate, being as a noise transmission path, and connected to a ground of the electronic product; and at least one first resonance unit comprising a plurality of first resonator, each of the first resonators comprising a first metal segment and a first conductive connection segment that is connected to the first metal segment, wherein when the first resonance unit is configured on the metal plate, each of the first metal segments is connected to the metal plate via the corresponding first conductive connection segment; wherein when the first resonators occur resonant, a noise transmitted on the metal plate will be conducted to the first resonators and suppressed by the first resonators.

In one embodiment of the present invention, wherein the first resonance unit further comprises a first substrate, the first metal segments are disposed on a surface of the first substrate, the first conductive connection segments are passing through the first substrate, the first resonance unit is configured on the metal plate via the first substrate.

In one embodiment of the present invention, wherein the first resonance unit is a dismountable element, the first resonance unit is fixed on the metal plate by a way of pasting, or by at least one fixed element.

In one embodiment of the present invention, wherein an upper surface and a lower surface of the metal plate are provided with the at least one first resonance unit, respectively.

In one embodiment of the present invention, wherein at least one first resistor is disposed on each of the first metal segments.

In one embodiment of the present invention, the noise suppression device further comprises at least one second resonance unit, the second resonance unit comprises a plurality of second resonator, each of the second resonators comprises a second metal segment and a second conductive connection segment that is connected to the second metal segment, each of the second metal segments is connected to the metal plate via the corresponding second conductive connection segment when the second resonance unit is configured on the metal plate, the noise transmitted on the metal plate will be conducted to the second resonators and suppressed by the second resonators when the second resonators occur resonant.

In one embodiment of the present invention, wherein the second resonance unit comprises a second substrate, the second metal segments are disposed on a surface of the second substrate, the second conductive connection segments are passing through the second substrate, the second resonance unit is configured on the metal plate via the second substrate.

In one embodiment of the present invention, wherein the noise suppression device further comprises a substrate, the first metal segments the second metal segments are disposed on a surface of the substrate, the first conductive connection segments and the second conductive connection segments are passing through the substrate, the first resonance unit and the second resonance unit are configured on the metal plate via the substrate.

In one embodiment of the present invention, the noise suppression device further comprises at least one third resonance unit, the third resonance unit comprises a plurality of third resonator, each of the third resonators comprises a third metal segment and a third conductive connection segment that is connected to the third metal segment, at least one third resistor is disposed on each of the third metal segments, each of the third metal segments is connected to the metal plate via the corresponding third conductive connection segment when the third resonance unit is con-

figured on the metal plate, the noise transmitted on the metal plate will be conducted to the third resonators and suppressed by the third resonators when the third resonators occur resonant.

In one embodiment of the present invention, where the third resonance unit comprises a third substrate, the third metal segments are disposed on a surface of the third substrate, the third conductive connection segments are passing through the third substrate, the third resonance unit is configured on the metal plate via the third substrate.

In one embodiment of the present invention, the third substrate is a soft substrate or a flexible substrate.

In one embodiment of the present invention, wherein the noise suppression device further comprises a substrate, the first metal segments, the second metal segments, and the third metal segments are disposed on a surface of the substrate, the first conductive connection segments, the second conductive connection segments, and the third conductive connection segments are passing through the substrate, the first resonance unit, the second resonance unit, and the third resonance unit are configured on the metal plate via the substrate.

In one embodiment of the present invention, the substrate is a soft substrate or a flexible substrate.

In one embodiment of the present invention, wherein the second resonance unit or the third resonance unit is a dismountable element, the second resonance unit or the third resonance unit is fixed on the metal plate by a way of pasting, or by at least one fixed element.

The present invention further provides an equivalent circuit of a noise suppression device, comprising: a first equivalent transmission line model, comprising: a first master transmission conductor, connected at one port thereof to an input end, and connected at other port thereof to an output end; and a first slave transmission conductor, which is disposed on a return path; and at least one first resonance circuit model comprising a first inductor and a first capacitor, the first inductor and the first capacitor are connected in series between the input end and the return path, connected in series between the output end and the return path, or connected in series between the first master transmission conductor and the first slave transmission conductor; wherein when the first resonance circuit model occurs resonant, a noise transmitted by the first equivalent transmission line model will be conducted to the first resonance circuit model and suppressed by the first resonance circuit model.

In one embodiment of the present invention, wherein the first resonance circuit model further comprises a first resistor, the first resistor, the first inductor, and the first capacitor are connected in series between the input end and the return path.

In one embodiment of the present invention, wherein the equivalent circuit further comprises a second resonance circuit model, the second resonance circuit model comprises a second inductor and a second capacitor, the second inductor and the second capacitor are connected in series between the output end and the return path, the noise transmitted by the first equivalent transmission line model will be conducted to the second resonance circuit model and suppressed by the second resonance circuit model when the second resonance circuit model occurs resonant.

In one embodiment of the present invention, the equivalent circuit further comprises a second resonance circuit model, a second equivalent transmission line model, and a third resonance circuit model, the second equivalent transmission line model comprises a second master transmission

conductor and a second slave transmission conductor, the first master transmission conductor is connected to the output end via the second master transmission conductor, the second slave transmission conductor is disposed on the return path, the second resonance circuit model comprises a second inductor and a second capacitor, the second inductor is connected at an end thereof to the first master transmission conductor and the second master transmission conductor, the second capacitor is connected at an end thereof to other end of the second inductor, and connected at other end thereof to the first slave transmission conductor and the second slave transmission conductor, the third resonance circuit model comprises a third inductor and a third capacitor, the third inductor and the third capacitor are connected in series between the output end and the return path; wherein when the second resonance circuit model or the third resonance circuit model occurs resonant, the noise transmitted by the first equivalent transmission line model or the second equivalent transmission line model will be conducted to the second resonance circuit model or the third resonance circuit model, and suppressed by the second resonance circuit model or the third resonance circuit model.

In one embodiment of the present invention, wherein the third resonance circuit model comprises a third resistor, the third resistor, the third inductor, and the third capacitor are connected in series between the output end and the return path.

BRIEF DESCRIPTION OF THE DRAWINGS

FIG. 1 is a three-dimensional structural view and a cross-section view of a noise suppression device according to one embodiment of the present invention.

FIG. 2 is a cross-section view of a noise suppression device according to one embodiment of the present invention.

FIG. 3 is a circuit diagram of an equivalent circuit of the noise suppression device shown in FIG. 1 according to one embodiment of the present invention.

FIG. 4 is a waveform diagram obtained by proceeding the measurement for transmission coefficient of the noise suppression device shown in FIG. 1 of the present invention.

FIG. 5 is a three-dimensional structural view of a noise suppression device according to another embodiment of the present invention.

FIG. 6 is a cross-section view of a noise suppression device according to another embodiment of the present invention.

FIG. 7 is a circuit diagram of an equivalent circuit of the noise suppression device shown in FIG. 5 according to another embodiment of the present invention.

FIG. 8 is a three-dimensional structural view of a noise suppression device according to another embodiment of the present invention.

FIG. 9 is a three-dimensional structural view of a noise suppression device according to another embodiment of the present invention.

FIG. 10 is a circuit diagram of an equivalent circuit of the noise suppression device shown in FIG. 8 according to another embodiment of the present invention.

FIG. 11 is a waveform diagram obtained by proceeding the measurement of S parameter for the noise suppression device shown in FIG. 8 of the present invention.

FIG. 12 is a waveform diagram of noise absorption rate of the noise suppression device shown in FIG. 8 of the present invention.

5

FIG. 13 is a three-dimensional structural view of a noise suppression device according to another embodiment of the present invention.

FIG. 14 is a three-dimensional structural view of a noise suppression device according to another embodiment of the present invention.

FIG. 15 is a circuit diagram of an equivalent circuit of the noise suppression device shown in FIG. 13 according to another embodiment of the present invention.

FIG. 16 is a waveform diagram of noise absorption rate of the noise suppression device shown in FIG. 13 of the present invention.

DETAILED DESCRIPTION OF THE PREFERRED EMBODIMENTS

Referring to FIG. 1 and FIG. 2, there are shown a three-dimensional structural view and a cross-section view of a noise suppression device according to one embodiment of the present invention. As shown in FIG. 1 and FIG. 2, the noise suppression device 500 is configured in the inside or the outside of an electronic product, and used to suppress a noise in the electronic product. The noise suppression device 500 comprises a metal plate 51 and at least one first resonance unit 53. The metal plate 51 is as a noise transmission path, and connected to a ground of the electronic product. The metal plate 51 is grounded in direct current, the noise can be transmitted on the metal plate 51 when the noise suppression device 500 is operated in a high-frequency. The first resonance unit 53 comprises a plurality of first resonator 54. Each of the first resonators 54 comprising a first metal segment 541 and at least one first conductive connection segment 543. The first metal segment 541 is connected at an end thereof to the first conductive connection segment 543. When the first resonance unit 53 is configured on the metal plate 51, each of the first metal segments 541 is connected to the metal plate 51 via the corresponding first conductive connection segment 543. In one embodiment of the present invention, each of the first metal segments 541 is connected to the metal plate 51 via a single first conductive connection segment 543. In another embodiment of the present invention, each of the first metal segments 541 is connected to the metal plate 51 via a plurality of first conductive connection segments 543.

In one embodiment of the present invention, each of the first resonators 54 is directly soldered on the metal plate 51 via the first conductive connection segment 543. In another embodiment of the present invention, the first resonance unit 53 further comprises a first substrate 530, the first metal segments 541 are disposed on a surface of the first substrate 530, the first conductive connection segments 543 are passing through the first substrate 530, thereby the first resonance unit 53 is configured on the metal plate 51 via the first substrate 530. Besides, the first resonance unit 53 may be a dismountable element. The first resonance unit 53, by the first substrate 530, is fixed on the metal plate 51 by a way of pasting, or by at least one fixed element.

In the present embodiment, the first resonators 54 are designed as reflective resonators. When the first resonators 54 occur resonant, a noise transmitted on the metal plate 51 will be conducted to the first resonators 54 and reflected by the first resonators 54.

In one embodiment of the present invention, the upper surface of the metal plate 51 is provided with at least one first resonance unit 53. In another embodiment of the present

6

invention, the upper surface and the lower surface of the metal plate 51 are provided with at least one first resonance unit 53, respectively.

Referring to FIG. 3, there is shown a circuit diagram of an equivalent circuit of the noise suppression device shown in FIG. 1 according to one embodiment of the present invention. As shown in FIG. 3, the equivalent circuit 600 comprises at least one first resonance circuit model 61 and a first equivalent transmission line model 63. The first resonance circuit model 61 comprises a first inductor 613 and a first capacitor 615. The first inductor 613 and the first capacitor 615 are an LC equivalent circuit formed by the first metal segment 541 and the first conductive connection segment 543. In one embodiment of the present invention, the first inductor 613 and the first capacitor 615 are connected in series between an input end and a return path. In other embodiment of the present invention, otherwise, the first inductor 613 and the first capacitor 615 are connected in series between an output end and the return path. The first equivalent transmission line model 63 comprises a first master transmission conductor 631 and a first slave transmission conductor 633. The first master transmission conductor 631 is an equivalent element of the metal plate 51, and the first slave transmission conductor 633 is an equivalent element of a reference metal surface or an earth ground. The first master transmission conductor 631 is grounded in direct current. The noise can be transmitted on the first master transmission conductor 631 and the first slave transmission conductor 633 when the the equivalent circuit 600 is operated in a high-frequency. The first master transmission conductor 631 is connected at one port thereof to the input end, and connected at other port thereof to an output end. The first slave transmission conductor 633 is disposed on the return path. When the first resonance circuit model 61 occurs resonant, a noise transmitted by the first equivalent transmission line model 63 will be conducted to the first resonance circuit model 61 and reflected by the first resonance circuit model 61. In another embodiment of the present invention, of course, the first inductor 613 and the first capacitor 615 can be also connected in series between the first master transmission conductor 631 and the first slave transmission conductor 633.

Referring to FIG. 4, there is shown a waveform diagram obtained by proceeding the measurement for transmission coefficient of the noise suppression device shown in FIG. 1 of the present invention. As shown in FIG. 4, a curve 741 of a transmission coefficient $|S_{21}|$ is obtained by the measurement for the transmission coefficient of the metal plate 51 without the noise suppression device 500, and a curve 743 of a transmission coefficient $|S_{21}|$ is obtained by the measurement for the transmission coefficient of the metal plate 51 with the noise suppression device 500.

Between the frequency band of 2.46 GHz to 2.53 GHz, the transmission coefficient $|S_{21}|$ of the curve 743 will be less about -20 dB than the transmission coefficient $|S_{21}|$ of the curve 741. Thus, after the metal plate 51 is provided with the noise suppression device 500, it is possible to obtain a good noise suppression effect in a specific frequency band.

Referring to FIG. 5 and FIG. 6, there are shown a three-dimensional structural view and a cross-section view of a noise suppression device according to another embodiment of the present invention. As shown in FIG. 5 and FIG. 6, compared to the first resonator 54 of the noise suppression device 500 of the above embodiment, the first resonator 54 of the noise suppression device 501 of the present embodiment further comprises at least one first resistor 545. The

first resistor **545** is disposed on the first metal segment **541** and electrically connected to the first metal segment **541**.

The first resonator **54** of the present embodiment is designed as an absorption resonator. When the first resonator **54** occurs resonant, a noise transmitted on the metal plate **51** will be conducted to the first resonator **54** and absorbed or dissipated by the first resistor **545** of the first resonator **54**.

Referring to FIG. 7, there is shown a circuit diagram of an equivalent circuit of the noise suppression device shown in FIG. 5 according to another embodiment of the present invention. As shown in FIG. 7, compared to the first resonance circuit model **61** of the equivalent circuit **600** in FIG. 3, the first resonance circuit model **61** of the equivalent circuit **601** in FIG. 7 further comprises at least one first resistor **611**. The first resistor **611**, the first inductor **613**, and the first capacitor **615** are an RLC equivalent circuit formed by the first metal segment **541**, the first conductive connection segment **543**, and the first resistor **545**. The first resistor **611**, the first inductor **613**, and the first capacitor **615** are connected in series between the input end and the return path.

The first resonance circuit model **61** of the present embodiment is designed as a resonance circuit model of an absorption type. When the first resonance circuit model **61** occurs resonant, a noise transmitted by the first equivalent transmission line model **63** will be conducted to the first resonance circuit model **61** and absorbed by the first resistor **611** of the first resonance circuit model **61**.

Referring to FIG. 8, there is shown a three-dimensional structural view of a noise suppression device according to another embodiment of the present invention. As shown in FIG. 8, the noise suppression device **502** comprises a metal plate **51**, at least one first resonance unit **53**, and a second resonance unit **55**.

The first resonance unit **53** comprises a plurality of first resonator **54**. Each of the first resonators **54** comprising a first metal segment **541**, at least one first conductive connection segment **543**, and a first resistor **545**. The first metal segment **541** is connected at an end thereof to the first conductive connection segment **543**. The first resistor **545** is disposed on the first metal segment **541**, and electrically connected to the first metal segment **541**. When the first resonance unit **53** is configured on the metal plate **51**, each of the first metal segments **541** is connected to the metal plate **51** via the corresponding first conductive connection segment **543**.

The second resonance unit **55** comprises a plurality of second resonators **56**. Each of the second resonators **56** comprising a second metal segment **561** and at least one second conductive connection segment **563**. The second metal segment **561** is connected to the second conductive connection segment **563**. When the second resonance unit **55** is configured on the metal plate **51**, each of the second metal segments **561** is connected to the metal plate **51** via the corresponding second conductive connection segment **563**. In one embodiment of the present invention, each of the second metal segments **561** is connected to the metal plate **51** via a single second conductive connection segment **563**. In another embodiment of the present invention, each of the second metal segments **561** is connected to the metal plate **51** via a plurality of second conductive connection segments **563**.

In one embodiment of the present invention, each of the first resonators **54** and each of the second resonators **56** are directly soldered on the metal plate **51** via the first conductive connection segment **543** and the second conductive connection segment **563**, respectively.

In another embodiment of the present invention, on the contrary, the first resonance unit **53** further comprises a first substrate **530**, and the second resonance unit **55** further comprises a second substrate **550**. The first metal segments **541** are disposed on a surface of the first substrate **530**, the first conductive connection segments **543** are passing through the first substrate **530**. The second metal segments **561** are disposed on a surface of the second substrate **550**, the second conductive connection segments **563** are passing through the second substrate **550**. The first resonance unit **53** and the second resonance unit **55** may be dismountable elements, they may be fixed on the metal plate **51** via the first substrate **530** and the second substrate **550** in a way of pasting or by a way of fixed element.

When the noise suppression device **502** is operating, the second resonance unit **55** is for reflecting the noise transmitted on the metal plate **51**, the first resistors **545** of the first resonance unit **53** is for absorbing the noise reflected by the second resonance unit **55**, thereby the noise can be suppressed by the noise suppression device **502**.

Referring to FIG. 9, there is shown a three-dimensional structural view of a noise suppression device according to another embodiment of the present invention. In the embodiment of FIG. 8, the first resonators **54** of the first resonance unit **53** and the second resonators **56** of the second resonance unit **55** are respectively disposed on the different substrates **530**, **550**, for example, the first resonators **54** is disposed on the first substrate **530**, and the second resonators **56** is disposed on the second substrate **550**.

In the embodiment of FIG. 9, on the contrary, the first resonators **54** of the first resonance unit **53** and the second resonators **56** of the second resonance unit **55** may be disposed on the same substrate **520**. The first metal segments **541** and the second metal segments **561** are disposed on a surface of the substrate **520**, the first conductive connection segments **543** and the second conductive connection segments **563** are passing through the substrate **520**, thereby the first resonance unit **53** and the second resonance unit **55** are configured on the metal plate **51** via the substrate **520**. In one embodiment of the present invention, the substrate **520** is a soft substrate or a flexible substrate.

Referring to FIG. 10, there is shown a circuit diagram of an equivalent circuit of the noise suppression device shown in FIG. 8 according to another embodiment of the present invention. As shown in FIG. 10, the equivalent circuit **602** comprises a first resonance circuit model **61**, a first equivalent transmission line model **63**, and a second resonance circuit model **65**.

The first resonance circuit model **611** comprises a first resistor **611**, a first inductor **613**, and a first capacitor **615**. The first resistor **611**, the first inductor **613**, and the first capacitor **615** are an RLC equivalent circuit formed by the first metal segment **541**, the first conductive connection segment **543**, and the first resistor **545**. The first resistor **611**, the first inductor **613** and the first capacitor **615** are connected in series between an input end and a return path. The first equivalent transmission line model **63** comprises a first master transmission conductor **631** and a first slave transmission conductor **633**. The first master transmission conductor **631** is an equivalent element of the metal plate **51**, and the first slave transmission conductor **633** is an equivalent element of a reference metal surface or an earth ground. The first master transmission conductor **631** is connected at one port thereof to the input end, and connected at other port thereof to the output end. The first slave transmission conductor **633** is disposed on the return path. The second resonance circuit model **65** comprises a second inductor **653**

and a second capacitor **655**. The second inductor **653** and the second capacitor **655** are an LC equivalent circuit formed by the second metal segment **561** and the second conductive connection segment **563**. The second inductor **653** and the second capacitor **655** are connected in series between an output end and the return path.

When the second resonance circuit model **65** occurs resonant, a noise transmitted by the first equivalent transmission line model **63** will be conducted to the second resonance circuit model **65** and reflected by the second resonance circuit model **65**. When the first resonance circuit model **61** occurs resonant, a noise transmitted by the first equivalent transmission line model **63** or a noise reflected by the second resonance circuit model **65** will be conducted to the first resonance circuit model **61**, and therefore absorbed by the first resistor **611** of the first resonance circuit model **61**.

Referring to FIG. **11**, there is shown a waveform diagram obtained by proceeding the measurement of S parameter for the noise suppression device shown in FIG. **8** of the present invention. As shown in FIG. **11**, a curve **751** of an input reflection coefficient $|S_{11}|$, a curve **753** of a transmission coefficient $|S_{21}|$, and a curve **755** of an output reflection coefficient $|S_{22}|$ are obtained by the measurement of the input reflection coefficient $|S_{11}|$, the transmission coefficient $|S_{21}|$, and the output reflection coefficient $|S_{22}|$ with respect to the noise in the noise suppression device **502**.

It is known from the curve **751** of the input reflection coefficient $|S_{11}|$ and the curve **753** of the transmission coefficient $|S_{21}|$, the noise suppression device **502** can have a better absorption or dissipation effect for the input noise between the frequency band of 2.35 GHz to 2.556 Hz. Furthermore, it is known from the curve **755** of the output reflection coefficient $|S_{22}|$, the noise suppression device **502** can have a better reflection effect for the output noise between the frequency band of 2.35 GHz to 2.55 GHz.

Referring to FIG. **12**, there is shown a waveform diagram of noise absorption rate of the noise suppression device shown in FIG. **8** of the present invention. As shown in FIG. **12**, the curve **761** is a curve of noise absorption rate of input end of the noise suppression device **502**, and the curve **763** is a curve of noise absorption rate of output end of the noise suppression device **502**.

As shown in the curve **761**, the noise suppression device **502** will have more than 50% absorption rate for the inputted noise in the input end between the frequency band of 2.35 GHz to 2.55 GHz because it is provided at the input end thereof with the first resonance unit **53** of an absorption type. As shown in the curve **763**, the noise suppression device **502** does not generate a significantly absorption effect for the inputted noise in the input end between the frequency band of 2.35 GHz to 2.55 GHz because it is not provided with a resonance unit of an absorption type at the input end thereof.

Referring to FIG. **13**, there is shown a three-dimensional structural view of a noise suppression device according to another embodiment of the present invention. As shown in FIG. **13**, the noise suppression device **503** comprises a metal plate **51**, at least one first resonance unit **53**, a second resonance unit **55**, and a third resonance unit **57**.

The first resonance unit **53** comprises a plurality of first resonator **54**. Each of the first resonators **54** comprising a first metal segment **541**, at least one first conductive connection segment **543**, and a first resistor **545**. The first metal segment **541** is connected at an end thereof to the first conductive connection segment **543**. The first resistor **545** is disposed on the first metal segment **541**, and electrically connected to the first metal segment **541**. When the first

resonance unit **53** is configured on the metal plate **51**, each of the first metal segments **541** is connected to the metal plate **51** via the corresponding first conductive connection segment **543**.

The second resonance unit **55** comprises a plurality of second resonator **56**. Each of the second resonators **56** comprising a second metal segment **561** and at least one second conductive connection segment **563**. The second metal segment **561** is connected to the second conductive connection segment **563**. When the second resonance unit **55** is configured on the metal plate **51**, each of the second metal segments **561** is connected to the metal plate **51** via the corresponding second conductive connection segment **563**.

The third resonance unit **57** comprises a plurality of third resonator **58**. Each of the third resonators **58** comprising a third metal segment **581**, at least one third conductive connection segment **583**, and a third resistor **585**. The third metal segment **581** is connected at an end thereof to the third conductive connection segment **583**. The third resistor **585** is disposed on the third metal segment **581**, and electrically connected to the third metal segment **581**. When the third resonance unit **57** is configured on the metal plate **51**, each of the third metal segments **581** is connected to the metal plate **51** via the corresponding third conductive connection segment **583**. In one embodiment of the present invention, each of the third metal segments **581** is connected to the metal plate **51** via a single third conductive connection segment **583**. In another embodiment of the present invention, each of the third metal segments **581** is connected to the metal plate **51** via a plurality of third conductive connection segments **583**.

In one embodiment of the present invention, each of the first resonators **54**, each of the second resonators **56**, and each of the third resonators **58** are directly soldered on the metal plate **51** via the first conductive connection segment **543**, the second conductive connection segment **563**, and the third conductive connection segment **583**, respectively.

In another embodiment of the present invention, on the contrary, the first resonance unit **53** further comprises a first substrate **530**, the second resonance unit **55** further comprises a second substrate **550**, and the third resonance unit **57** further comprises a third substrate **570**. The first metal segments **541** are disposed on a surface of the first substrate **530**, the first conductive connection segments **543** are passing through the first substrate **530**. The second metal segments **561** are disposed on a surface of the second substrate **550**, the second conductive connection segments **563** are passing through the second substrate **550**. The third metal segments **581** are disposed on a surface of the third substrate **570**, the third conductive connection segments **583** are passing through the third substrate **570**. The first resonance unit **53**, the second resonance unit **55**, and the third resonance unit **57** may be dismountable elements, they may be fixed on the metal plate **51** via the first substrate **530**, the second substrate **550**, and the third substrate **570** in a way of pasting or by a way of fixed element, respectively. In one embodiment of the present invention, the first substrate **530**, the second substrate **550**, or the third substrate **570** is a soft substrate or a flexible substrate.

When the noise suppression device **503** is operating, the second resonance unit **55** is for reflecting the noise transmitted on the metal plate **51**, the first resistors **545** and the third resistors **585** of the first resonance unit **53** and the third resonance unit **57** are for absorbing the noise reflected by the second resonance unit **55**, respectively, thereby the noise can be suppressed by the noise suppression device **503**.

Referring to FIG. 14, there is shown a three-dimensional structural view of a noise suppression device according to another embodiment of the present invention. In the embodiment of FIG. 13, the first resonators 54 of the first resonance unit 53, the second resonators 56 of the second resonance unit 55, and the third resonators 58 of the third resonance unit 57 are respectively disposed on the different substrates, for example, the first resonators 54 are disposed on the first substrate 530, the second resonators 56 are disposed on the second substrate 550, and the third resonators 58 are disposed on the third substrate 570.

In the embodiment of FIG. 14, on the contrary, the first resonators 54 of the first resonance unit 53, the second resonators 56 of the second resonance unit 55, and the third resonators 58 of the third resonance unit 57 may be disposed on the same substrate 525. The first metal segments 541, the second metal segments 561, and the third metal segments 581 are disposed on a surface of the substrate 525, the first conductive connection segments 543, the second conductive connection segments 563, and the third conductive connection segments 583 are passing through the substrate 525, thereby the first resonance unit 53, the second resonance unit 55, and the third resonance unit 57 are configured on the metal plate 51 via the substrate 525. In one embodiment of the present invention, the substrate 525 is a soft substrate or a flexible substrate.

Referring to FIG. 15, there is shown a circuit diagram of an equivalent circuit of the noise suppression device shown in FIG. 13 according to another embodiment of the present invention. As shown in FIG. 15, the equivalent circuit 603 comprises a first resonance circuit model 61, a first equivalent transmission line model 63, a second resonance circuit model 65, a second equivalent transmission line model 67, and a third resonance circuit model 69.

The first resonance circuit model 61 comprises a first resistor 611, a first inductor 613, and a first capacitor 615. The first resistor 611, the first inductor 613, and the first capacitor 615 are an RLC equivalent circuit formed by the first metal segment 541, the first conductive connection segment 543, and the first resistor 545. The first resistor 611, the first inductor 613 and the first capacitor 615 are connected in series between an input end and a return path.

The first equivalent transmission line model 63 comprises a first master transmission conductor 631 and a first slave transmission conductor 633. The second equivalent transmission line model 67 comprises a second master transmission conductor 671 and a second slave transmission conductor 673. The first master transmission conductor 631 and the second master transmission conductor 671 are equivalent elements of the metal plate 51, and the first slave transmission conductor 633 and the second slave transmission conductor 673 are equivalent elements of a reference metal surface or an earth ground. The first master transmission conductor 631 and the second master transmission conductor 671 are connected in serial between the input end and the output end, and the first slave transmission conductor 633 and the second slave transmission conductor 673 are connected in serial on the return path. The first master transmission conductor 631 and the second master transmission conductor 671 are grounded in direct current. The noise can be transmitted on the first master transmission conductor 631, the second master transmission conductor 671, the first slave transmission conductor 633, and the second slave transmission conductor 673 when the the equivalent circuit 603 is operated in a high-frequency.

The second resonance circuit model 65 comprises a second inductor 653 and a second capacitor 655. The second

inductor 653 and the second capacitor 655 are an LC equivalent circuit formed by the second metal segment 561 and the second conductive connection segment 563. The second inductor 653 is connected at an end thereof to the first master transmission conductor 631 and the second master transmission conductor 671. The second capacitor 655 is connected at an end thereof to other end of the second inductor 653, and connected at other end thereof to the first slave transmission conductor 633 and the second slave transmission conductor 673.

The third resonance circuit model 69 comprises a third resistor 691, a third inductor 693, and a third capacitor 695. The third resistor 691, the third inductor 693, and the third capacitor 695 are an RLC equivalent circuit formed by the third metal segment 581, the third conductive connection segment 583, and the third resistor 585. The third resistor 691, the third inductor 693, and the third capacitor 695 are connected in series between the input end and the return path.

When the second resonance circuit model 65 occurs resonant, a noise transmitted by the first equivalent transmission line model 63 or the second equivalent transmission line model 67 will be conducted to the second resonance circuit model 65 and reflected by the second resonance circuit model 65. When the first resonance circuit model 61 or the third resonance circuit model 69 occurs resonant, a noise transmitted by the first equivalent transmission line model 63 or the second equivalent transmission line model 67, or a noise reflected by the second resonance circuit model 65 will be conducted to the first resonance circuit model 61 or the third resonance circuit model 69, and therefore absorbed by the first resistor 611 of the first resonance circuit model 61 or the third resistor 691 of the third resonance circuit model 69.

Referring to FIG. 16, there is shown a waveform diagram of noise absorption rate of the noise suppression device shown in FIG. 13 of the present invention. As shown in FIG. 16, the curve 771 is a curve of noise absorption rate of input end of the noise suppression device 503, and the curve 773 is a curve of noise absorption rate of output end of the noise suppression device 503.

As shown in the curve 771, the noise suppression device 503 will have more than 50% absorption rate for the inputted noise in the input end between the frequency band of 2.35 GHz to 2.55 GHz because it is provided at the input end thereof with the first resonance unit 53 of an absorption type. As shown in the curve 773, the noise suppression device 503 will have more than 50% absorption rate for the inputted noise in the output end between the frequency band of 2.35 GHz to 2.55 GHz because it is provided at the output end thereof with the third resonance unit 57 of an absorption type. Accordingly, the noise suppression device 503 can achieve the effect for bidirectional absorbing the noise via the resonance units 53 and 57 provided at the input end and the output end.

The above disclosure is only the preferred embodiment of the present invention, and not used for limiting the scope of the present invention. All equivalent variations and modifications on the basis of shapes, structures, features and spirits described in the claims of the present invention should be included in the claims of the present invention.

What is claimed is:

1. A noise suppression device for application in an electronic product, the noise suppression device comprising:
 - a metal plate providing a noise transmission path, and
 - connected to a ground of the electronic product; and

13

at least one first resonance unit including a plurality of first resonators, each of the plurality of first resonators including:

a first metal segment,

a first conductive connection segment that is connected to the first metal segment, and

at least one first resistor disposed on the first metal segment and separated from the first conductive connection segment by the first metal segment;

wherein, when the at least one first resonance unit is configured on the metal plate, each of the first metal segments is connected to the metal plate via the corresponding first conductive connection segment; and wherein, when the plurality of first resonators undergo resonance, a noise transmitted on the metal plate is conducted to the plurality of first resonators and suppressed by the plurality of first resonators.

2. The noise suppression device according to claim 1, wherein the first resonance unit further includes a first substrate, the first metal segments being disposed on a surface of the first substrate, the first conductive connection segments passing through the first substrate, the at least one first resonance unit being configured on the metal plate via the first substrate.

3. The noise suppression device according to claim 2, wherein the first substrate is a soft substrate or a flexible substrate.

4. The noise suppression device according to claim 1, wherein the metal plate is grounded in direct current, and the noise is transmittable on the metal plate when the noise suppression device is operated in a high frequency.

5. The noise suppression device according to claim 1, wherein an upper surface and a lower surface of the metal plate are provided with the at least one first resonance unit, respectively.

6. The noise suppression device according to claim 1, further comprising at least one second resonance unit including a plurality of second resonators, each of the plurality of second resonators including a second metal segment and a second conductive connection segment that is connected to the second metal segment,

wherein each of the second metal segments is connected to the metal plate via the corresponding second conductive connection segment when the at least one second resonance unit is configured on the metal plate, and

wherein the noise transmitted on the metal plate is conducted to the plurality of second resonators and suppressed by the plurality of second resonators when the plurality of second resonators undergo resonance.

7. The noise suppression device according to claim 6, further comprising a substrate, the first metal segments and the second metal segments being disposed on a surface of the substrate, the first conductive connection segments and the second conductive connection segments passing through the substrate, the at least one first resonance unit and the at least one second resonance unit being configured on the metal plate via the substrate.

8. The noise suppression device according to claim 6, wherein the at least one second resonance unit includes a second substrate, the second metal segments being disposed on a surface of the second substrate, the second conductive connection segments passing through the second substrate, the at least one second resonance unit being configured on the metal plate via the second substrate.

14

9. The noise suppression device according to claim 8, wherein the second substrate is a soft substrate or a flexible substrate.

10. The noise suppression device according to claim 6, further comprising at least one third resonance unit including a plurality of third resonators, each of the plurality of third resonators including a third metal segment and a third conductive connection segment that is connected to the third metal segment, at least one third resistor being disposed on each of the third metal segments,

wherein each of the third metal segments is connected to the metal plate via the corresponding third conductive connection segment when the at least one third resonance unit is configured on the metal plate, and

wherein the noise transmitted on the metal plate is conducted to the plurality of third resonators and suppressed by the plurality of third resonators when the plurality of third resonators undergo resonance.

11. The noise suppression device according to claim 10, wherein the at least one second resonance unit or the at least one third resonance unit is a dismountable element fixed on the metal plate by pasting or by at least one fixed element.

12. The noise suppression device according to claim 10, wherein the third resonance unit includes a third substrate, the third metal segments being disposed on a surface of the third substrate, the third conductive connection segments passing through the third substrate, the at least one third resonance unit being configured on the metal plate via the third substrate.

13. The noise suppression device according to claim 12, wherein the third substrate is a soft substrate or a flexible substrate.

14. The noise suppression device according to claim 10, further comprising a substrate,

the first metal segments, the second metal segments, and the third metal segments being disposed on a surface of the substrate,

the first conductive connection segments, the second conductive connection segments, and the third conductive connection segments passing through the substrate, the at least one first resonance unit, the at least one second resonance unit, and the at least one third resonance unit being configured on the metal plate via the substrate.

15. The noise suppression device according to claim 14, wherein the substrate is a soft substrate or a flexible substrate.

16. A noise suppression device for application in an electronic product, the noise suppression device comprising: a metal plate providing a noise transmission path, and connected to a ground of the electronic product; and at least one first resonance unit including a plurality of first resonators, each of the plurality of first resonators including:

a first metal segment, and

a first conductive connection segment that is connected to the first metal segment;

wherein the first resonance unit is a dismountable element which is fixed on the metal plate by pasting or by at least one fixed element;

wherein, when the at least one first resonance unit is fixed on the metal plate, each of the first metal segments is connected to the metal plate via the corresponding first conductive connection segment; and

wherein, when the plurality of first resonators undergo resonance, a noise transmitted on the metal plate is conducted to the plurality of first resonators and suppressed by the plurality of first resonators.

15

17. The noise suppression device according to claim 16, wherein at least one first resistor is disposed on each of the first metal segments.

18. An equivalent circuit of a noise suppression device, comprising:

a first equivalent transmission line model including:

a first master transmission conductor connected at one port thereof to an input end, and connected at another port thereof to an output end, and

a first slave transmission conductor disposed on a return path; and

at least one first resonance circuit model including a first resistor, a first inductor, and a first capacitor connected in order in series between the input end and the return path;

wherein, when the at least one first resonance circuit model undergoes resonance, a noise transmitted by the first equivalent transmission line model is conducted to the at least one first resonance circuit model and suppressed by the at least one first resonance circuit model.

19. The equivalent circuit according to claim 18, wherein the first master transmission conductor is grounded in direct current.

20. The equivalent circuit according to claim 18, further comprising a second resonance circuit model including a second inductor and a second capacitor connected in series between the output end and the return path,

wherein the noise transmitted by the first equivalent transmission line model is conducted to the second resonance circuit model and suppressed by the second resonance circuit model when the second resonance circuit model undergoes resonance.

21. The equivalent circuit according to claim 18, further comprising:

16

a second resonance circuit model including a second inductor and a second capacitor;

a second equivalent transmission line model including a second master transmission conductor and a second slave transmission conductor, the first master transmission conductor being connected to the output end via the second master transmission conductor, the second slave transmission conductor being disposed on the return path; and

a third resonance circuit model including a third inductor and a third capacitor connected in series between the output end and the return path;

wherein the second inductor is connected at an end thereof to the first master transmission conductor and the second master transmission conductor,

wherein the second capacitor is connected at an end thereof to another end of the second inductor, and connected at another end thereof to the first slave transmission conductor and the second slave transmission conductor, and

wherein, when the second resonance circuit model or the third resonance circuit model undergoes resonance, the noise transmitted by the first equivalent transmission line model or the second equivalent transmission line model is conducted to the second resonance circuit model or the third resonance circuit model, and suppressed by the second resonance circuit model or the third resonance circuit model.

22. The equivalent circuit according to claim 21, wherein the third resonance circuit model includes a third resistor, and

wherein the third resistor, the third inductor, and the third capacitor are connected in series between the output end and the return path.

* * * * *